

Preliminary Ecuador Plant Design

AguaClara

Cornell University

February 2009

Executive Summary

The design team of AguaClara has come up with a preliminary design for a plant as per the request of Hugo Castillo. The plant is designed for a flow rate of 3 liters per second, and is powered by gravity. The plant is designed to treat turbid surface waters for distribution systems already in place. The Ecuador plant design contains two separate sedimentation tanks, three flocculator channels, and an entrance and exit channel. The plant has a footprint of approximately 10.5 square meters.

The following document contains an overview of the plant design, including drawings, dimensions, and overall process descriptions. It should be noted that this is a preliminary design and is subject to change as continuing research brings forth design changes.

Table of Contents

1. Design Overview	5
2. Entrance Tank	6
3. Flocculator	7
3.1. <i>Construction Suggestions</i>	7
4. Inlet Channel	9
5. Sedimentation Tank	10
5.1. <i>Inlet Slopes</i>	11
5.1.1. <i>Construction Suggestions</i>	11
5.2. <i>Sedimentation Tank</i>	14
5.3. <i>Sludge Drain</i>	15
5.4. <i>Lamella</i>	16
5.5. <i>Effluent Launder</i>	17
6. Exit Channel	18

Table of Figures

Figure 1: Ecuador Plant Design	5
Figure 2: Flocculator Design.....	8
Figure 3: Inlet Channel – Top View	9
Figure 4: Inlet Channel – Isometric View	9
Figure 5: Sedimentation Tank Cross Section with labeled elements.....	10
Figure 6: Photo of Inlet Slopes Construction	12
Figure 7: Port Construction and Layout Example	12
Figure 8: Inlet Slopes Cross Section	13
Figure 9: Sedimentation Tank.....	14

Figure 10: Sludge Drain	15
Figure 11: Lamella Design	16
Figure 12: Effluent Launder Design.....	17
Figure 13: Exit Channel – Top View.....	18
Figure 14: Exit Channel – Isometric View.....	18

1. Design Overview

The automated design process breaks up the plant design into nine different elements: entrance tank, flocculator, inlet channel, sedimentation inlet slopes, sedimentation tank, settling plates (lamella), sludge drain, sedimentation effluent launder, and exit channel. Given a flow rate and specifications for the materials that will be used, the program is designed to make all necessary calculations and output dimensions for the plant. It is up to on-site engineers to conduct construction details and perform any surveying that may be necessary.

The following report outlines the different design elements and processes associated with the plant, including drawings with dimensions. Every element of the plant follows a variable naming guideline, which can be found online. However, in this report a description is given next to the dimension, with a rendered image showing those dimensions. Please note that the given dimensions are not an exhaustive list, but are a general overview to give an idea of what the plant will look like.

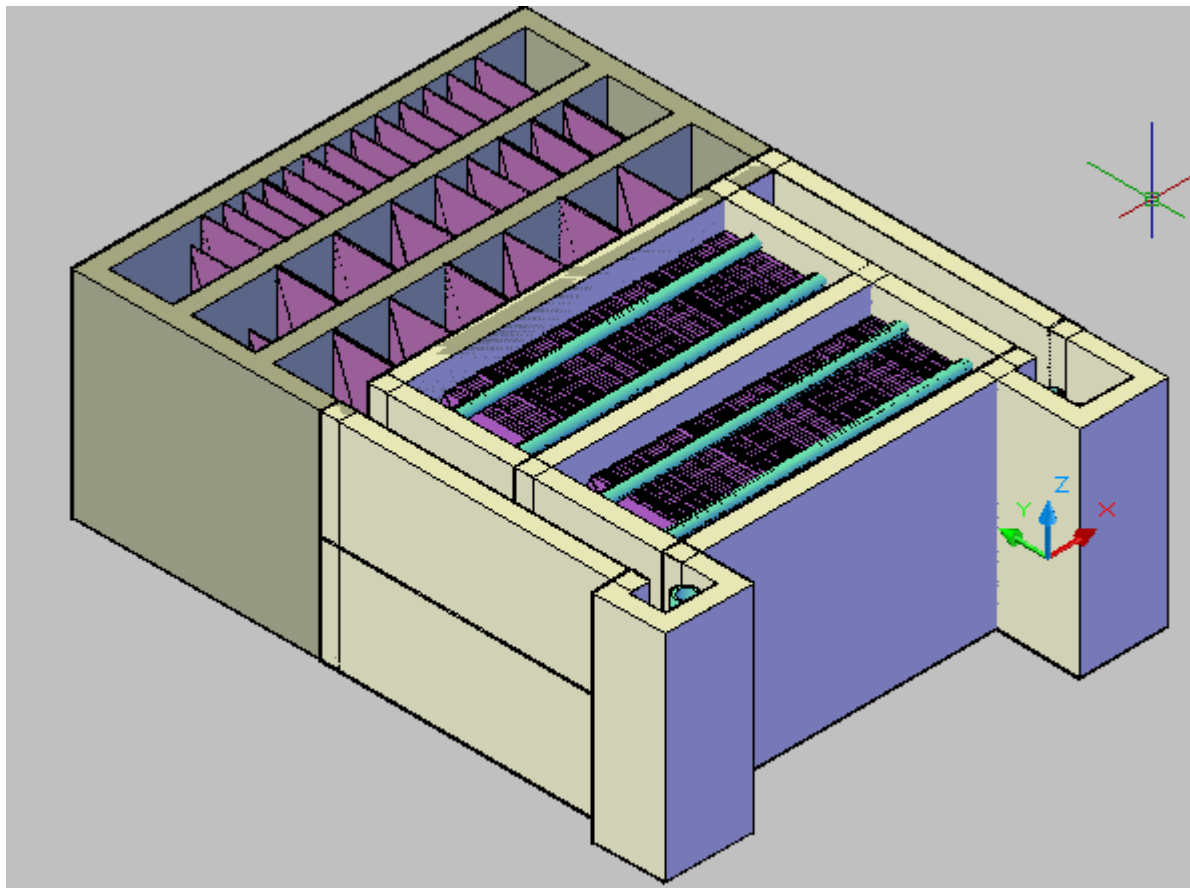

Figure 1: Ecuador Plant Design

2. Entrance Tank

The entrance tank feeds water from the source to the plant and causes rapid mixing to take place as chemicals are fed into the water. The plant is designed for 60mg/L of aluminum sulfate to serve as coagulant, however this concentration can be changed. The water then flows through a riser pipe called a linear flow orifice meter (LFOM) so as to create a linear relationship between the height of the water in the entrance tank and the flow rate through the plant.

The number of orifices and diameter of the orifices are calculated in the program, as well as the diameter of the riser pipe. The dimensions for the entrance tank are also given. The following are the particular dimensions for the plant's entrance tank:

Dimension	MathCAD Variable Name	
Length	L_{Et}	1.5m
Width	W_{Et}	0.75m
LFOM Pipe Diameter	ND_{Lfom}	12in
Height	H_{Et}	2.02m

3. Flocculator

The flocculation tanks serve to mix the water with aluminum sulfate to promote flocculation. Flocculation is a simple gravity driven process that creates flocs (collections of particles) which settle out in the sedimentation tank. The flocculator is divided into vertical channels by baffles and the water flows up and down through these channels.

Before entering the floc tank, the water is mixed with aluminum sulfate which acts as a coagulant. Each 180 degree turn through the flocculator encourages mixing and collisions of the particles. Each collision offers a small probability of sticking, and as a floc proceeds through the tank it increases in size. The larger it gets, the more likely it is to settle out in the sedimentation tank.

The flocculation program calculates the dimensions of the flocculator, the number of flocculation channels needed for adequate mixing, and the number and spacing of the baffles. The baffles are composed of corrugated sheeting, constructed in a set number of modules. Separating the baffles into separate modules allows them to be removed easily and also allows easy access for cleaning the tank.

The following are the dimensions for the flocculation tanks:

Dimension	MathCAD Variable Name	
Width	$W_{\text{FlocChannel}}$	0.46m
Length	$L_{\text{FlocChannel}}$	2.01m
Number of baffles	$N_{\text{FlocBaffles}}$	91
Number of floc channels	$N_{\text{FlocChannels}}$	3

3.1. Construction Suggestions

The baffles are designed to have varying length and spacing, so as to promote flocculation more efficiently. It is suggested that modules are created for the baffles based on design parameters. Typically PVC pipes have been used to connect the baffles together in a single module. If further information is needed on this type of construction it can be made available. A table for suggested module arrangements will be provided later.

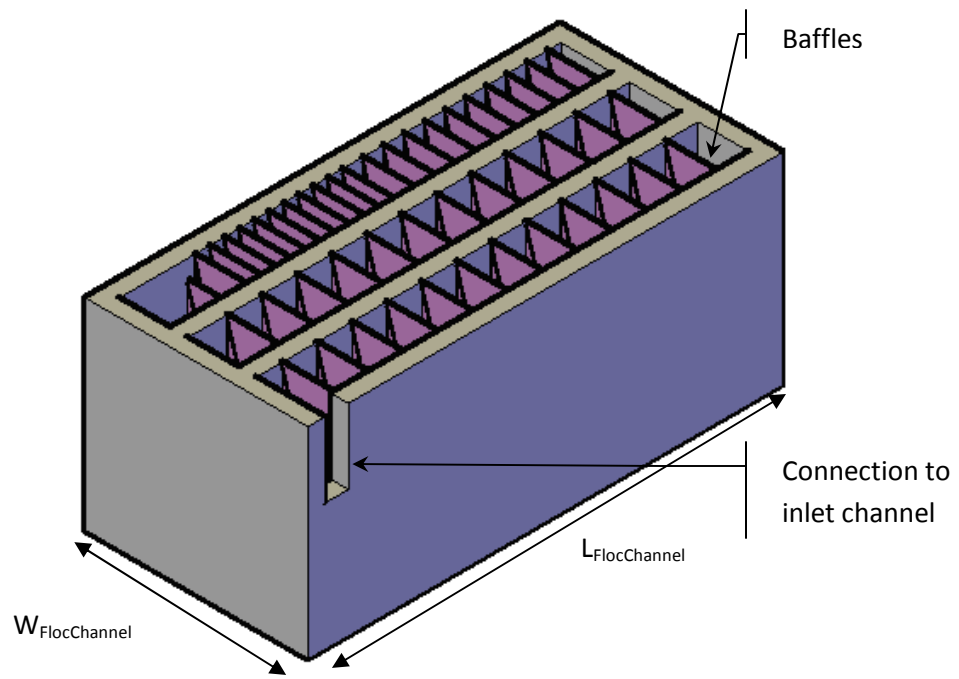

Figure 2: Flocculator Design

4. Inlet Channel

Water flows from the flocculator into the sedimentation tanks via the inlet channel. The channel runs along the inlet end of the sedimentation tanks, such that its length will be equal to the sum of the widths of the sedimentation tanks. The width and depth of the channel depend on the water level in the sedimentation tank, which is designed to be the same as in the channel and the flocculator.

The primary constraint for the inlet channel is the depth. The channel is designed to make sure that the transition between the flocculator and sedimentation tanks does not break up the flocs formed in the flocculator. The following are the dimensions for the plant's inlet channel:

Dimension	MathCAD Variable Name	
Width	$W_{\text{InletChannel}}$	0.21m
Height	$H_{\text{InletChannel}}$	0.563m
Length	L_{Channel}	2.14m

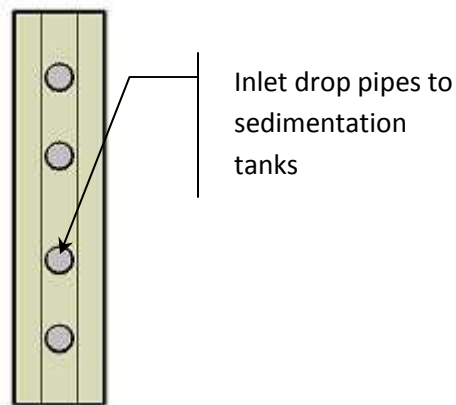

Figure 3: Inlet Channel – Top View

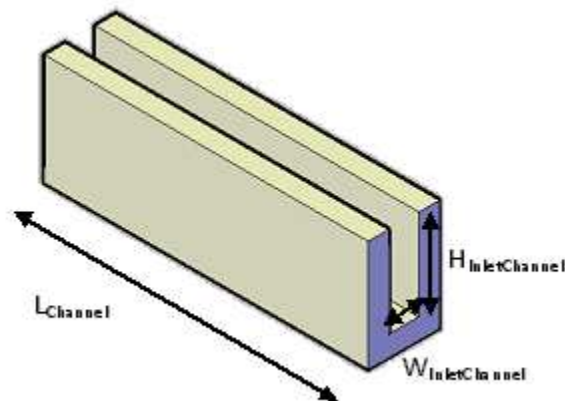

Figure 4: Inlet Channel – Isometric View

5. Sedimentation Tank

The following five sections describe the overall design of the sedimentation tanks. For reference, the following is a cross-section of the sedimentation tank.

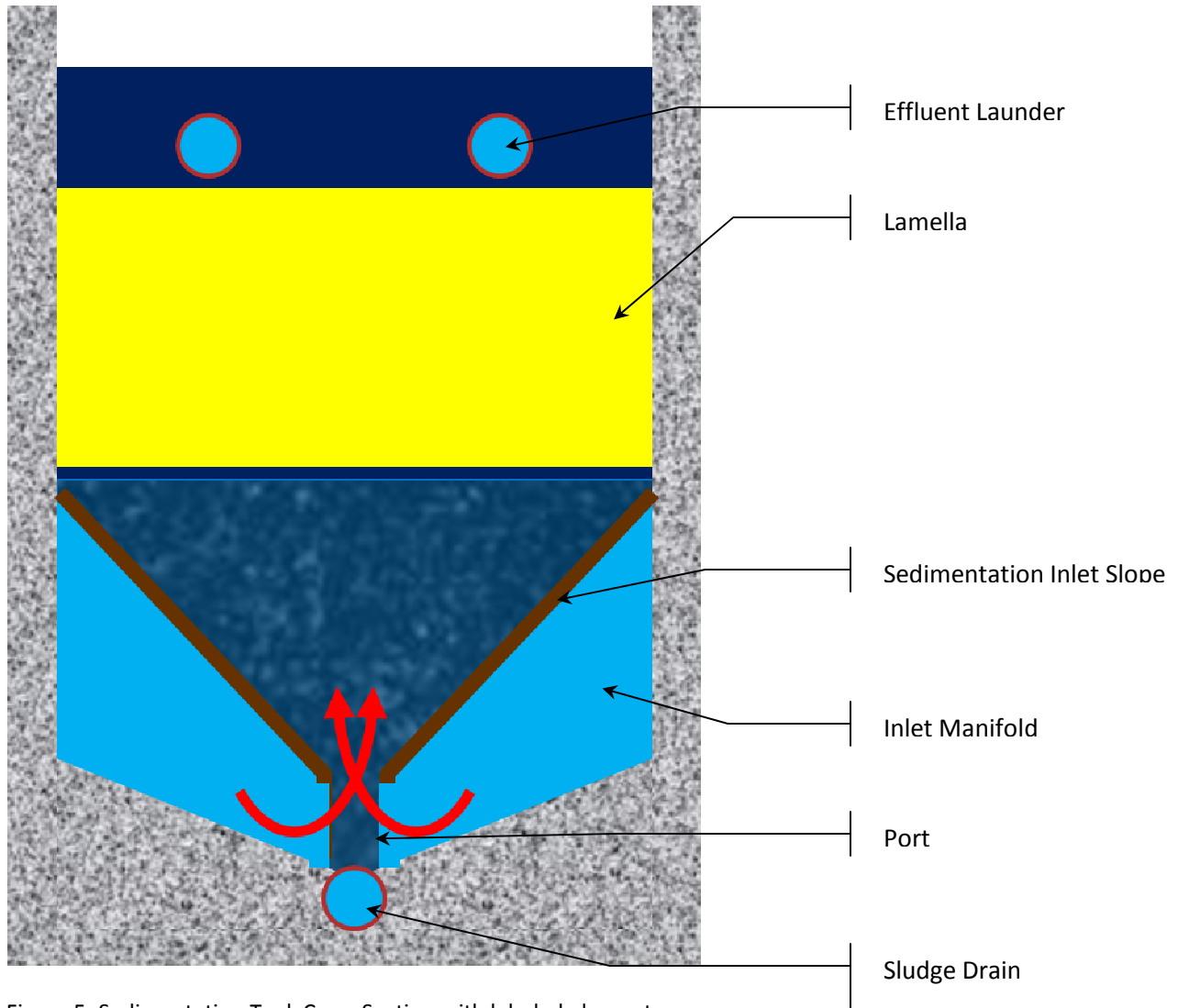

Figure 5: Sedimentation Tank Cross Section with labeled elements

Water flows through the inlet manifolds, out through the ports (as shown by the red arrows), up through the settler plates/lamella, and then out through the effluent launder. This process are described in the following sections.

5.1. Inlet Slopes

Water flows from the inlet channel into the sedimentation tanks through a manifold, also known as the sedimentation inlet slopes. These channels run along the length of the sedimentation tank and uniformly distribute water to the entire bottom of the tank, thus creating a uniform flow of water out of the slopes through ports and into the tank.

One of the major concerns with this design is ensuring the water flows uniformly into the sedimentation tank and that the velocity does not get too high as to break up the flocs. However, the velocity must be high enough so that the flocs don't settle in the slopes and decrease the area of the ports through which the water flows out.

The sedimentation tank for this plant is designed as a triangle due to the relatively low flow rate the plant is designed to handle. The ports are given as an area, and the shape can be determined later based on construction materials. However, the ports are recommended to be either square or rectangular.

The following are the dimensions for the design of the sedimentation inlet slopes.

Dimension	MathCAD Variable Name	
Top angle of the slope	$AN_{SedTopInlet}$	60 deg
Bottom angle of the slope	$AN_{SedBottom}$	10 deg
Vertical height of the slope	$Z_{SedSlopes}$	0.937m
Number of slopes in each sedimentation tank	$N_{TrianglesperTank}$	2
Number of ports in each slope	$N_{SedPorts}$	17
Area of ports	$A_{SedPort}$	33.6cm ²
Center to center spacing between ports	$W_{SedSlopePlate}$	30cm

5.1.1. Construction Suggestions

Previous communities have constructed the inlet slopes as plates made of ferrous cement. An example of this type of construction can be seen below in the Cuatro Comunidades plant.



Figure 6: Photo of Inlet Slopes Construction

Ports are cut out of the slopes, and since the spacing between the ports is a constant (set as 30cm for this plant), the plates can be constructed so two plates can meet to form one port. An illustration is shown below.

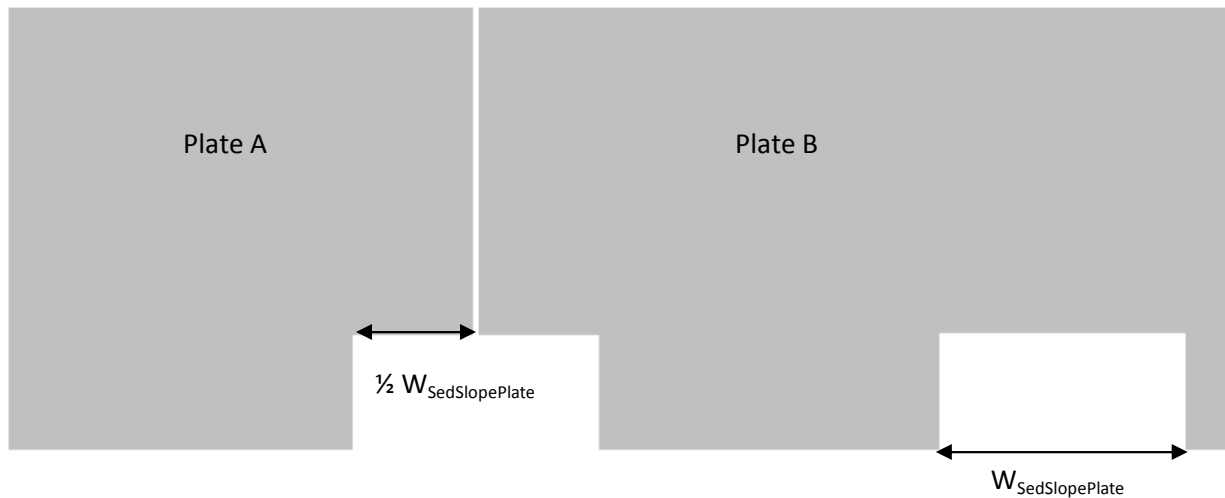

Figure 7: Port Construction and Layout Example

It is also important when constructing these slopes to make sure that the ports are so that they are not directly across from each other in the sedimentation tank. As the water flows out of the manifolds through the ports, collisions could occur if the ports are facing one another—staggering them will help eliminate this risk.

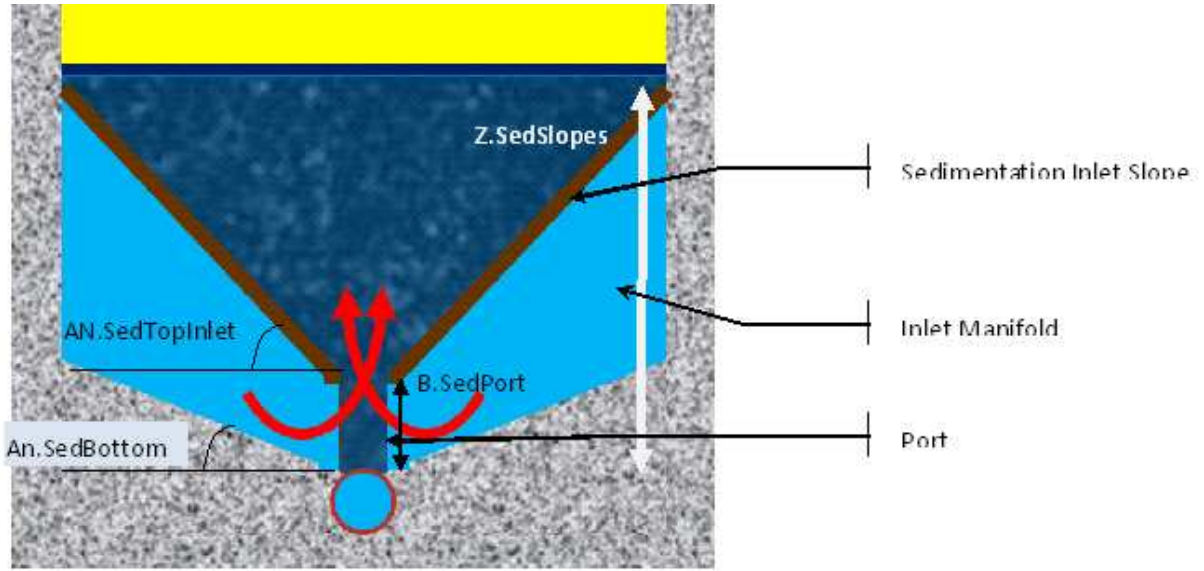

Figure 8: Inlet Slopes Cross Section

5.2. Sedimentation Tank

The design of the sedimentation tank is a critical piece of the design of the entire plant. Its properties, such as depth and critical velocity, are important in determining the dimensions and lamella spacing. The sedimentation tanks are designed to handle the plant's flow rate. The number of sedimentation tanks is set by the user, and has been set at two for this specific design. The length and width are then determined so as to create uniform flow into the sedimentation tanks without breaking the flocs.

The following are the dimensions for the sedimentation tanks.

Dimension	MathCAD Variable Name	
Number of sedimentation tanks	N_{SedTanks}	2
Height	H_{Sed}	1.65m
Length	L_{Sed}	2.01m
Width	W_{Sed}	0.92m

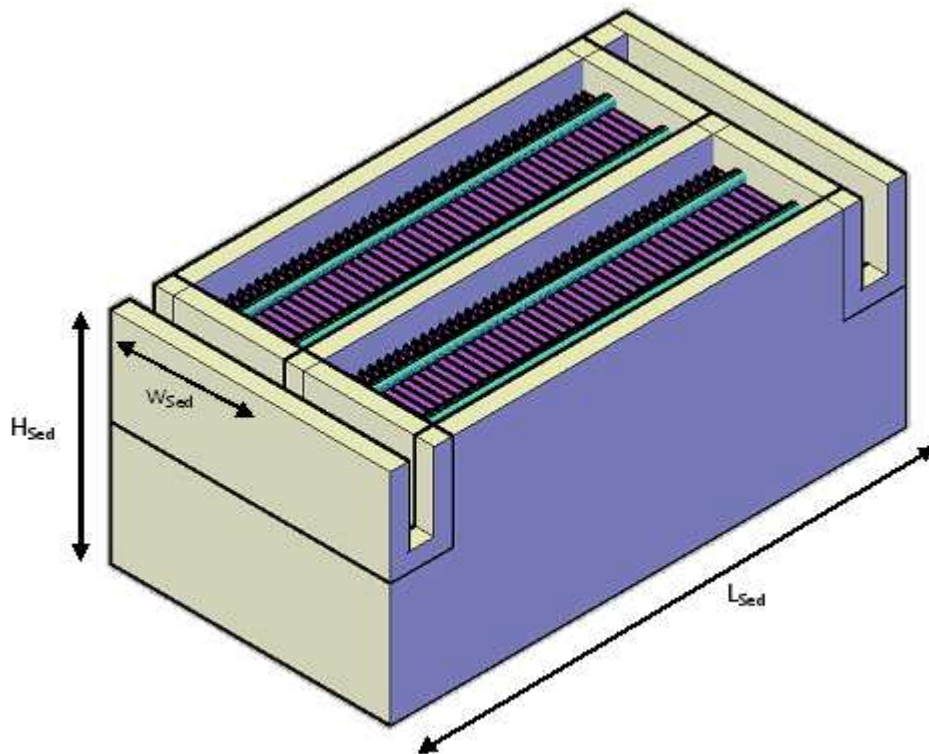

Figure 9: Sedimentation Tank

5.3. Sludge Drain

The sedimentation tank also includes a sludge drain for the settled flocs to be drained. The sludge drain runs along the bottom of each sedimentation tank and collects the flocs as they fall from the lamella and settle. The number of orifices in the sludge drain is determined by the length of the sedimentation tank and the spacing between each orifice, as defined by the user.

The following are the dimensions for the sludge drain.

Dimension	MathCAD Variable Name	
Number of orifices	$N_{\text{SedSludgeOrifices}}$	13
Diameter of orifices	$D_{\text{SedSludgeOrifices}}$	0.5in
Center to center distance between orifices	$B_{\text{SedSludgeOrifices}}$	15cm
Diameter of the sludge drain	$ND_{\text{SedSludge}}$	2in

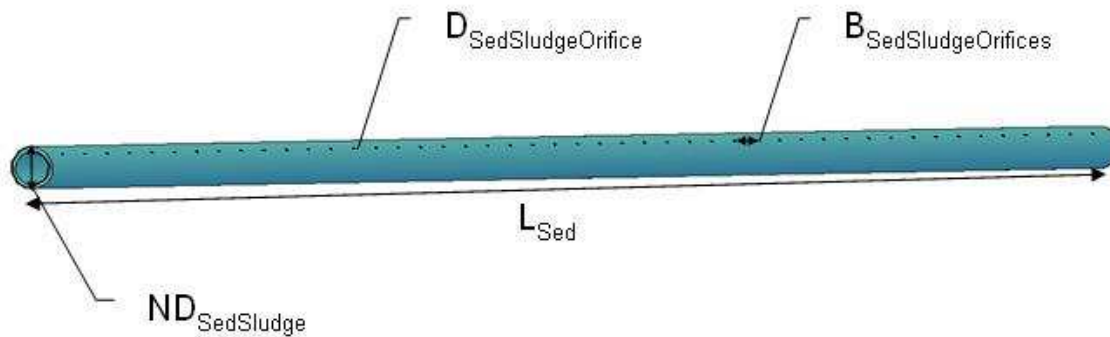

Figure 10: Sludge Drain

5.4. Lamella

The lamella (sometimes referred to as plate settlers) are located within each sedimentation tank and serve to promote the settling of the flocs. Similar to the construction of the baffles in the flocculator, they are composed of corrugated sheets, however they are constructed at a specified angle. As water flows up through the sedimentation tank, the flocs will collide with the lamella, thus increasing the likelihood of settling.

The important parameters in the design of the lamella are the critical velocity (10m/day) and the upward velocity at the bottom of the tank (70m/day). The critical velocity is the rate at which a particle must fall to ensure that it settles out within the plate settlers. The upward velocity at the bottom of the tank is important for the formation of the sludge blanket, which can be incorporated into the sedimentation tank. Research is still being conducted on this part of the plant and details for the floc blanket will be sent separately.

Note that each sheet is referred to as a “plate” and the plates make up the entire lamella. The following are the dimensions for the lamella.

Dimension	MathCAD Variable Name	
Center to center distance between each plate	$B_{SedPlate}$	1.637cm
Length of the plate	$L_{SedPlate}$	0.471m
Number of plates	$N_{SedPlates}$	58
Angle of the plates	$AN_{SedPlate}$	60 deg

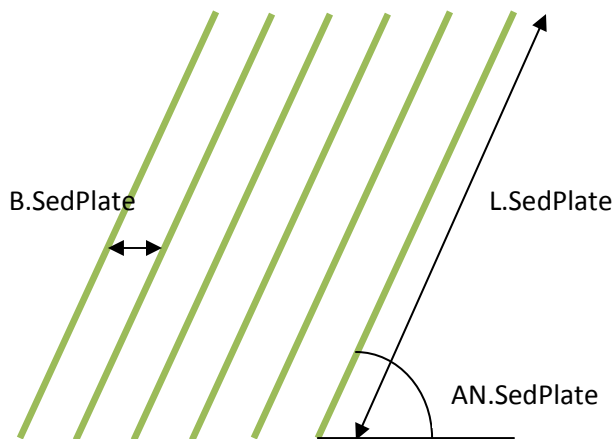

Figure 11: Lamella Design

5.5. Effluent Launder

The launder is the manifold that transports the clean water from the top of the sedimentation tank to the exit channel. The launder is located between the top of the lamella and the surface of the water in the sedimentation tank. There is one launder for every inlet slope. For this plant design there are two launders per sedimentation tank.

Orifices are drilled along the launder to carry the water through the manifold, similar to that of the sludge drain. Each launder will have two rows of orifices oriented along the side of the launder, making sure they are staggered so they do not align.

The following are the dimensions for the launders.

Dimension	MathCAD Variable Name	
Diameter of launder	$ND_{SedLaunder}$	3in
Number of orifices in launder (per row)	$N_{SedLaunderOrifices}$	28
Diameter of orifices	$D_{SedLaunderOrifices}$	0.313in

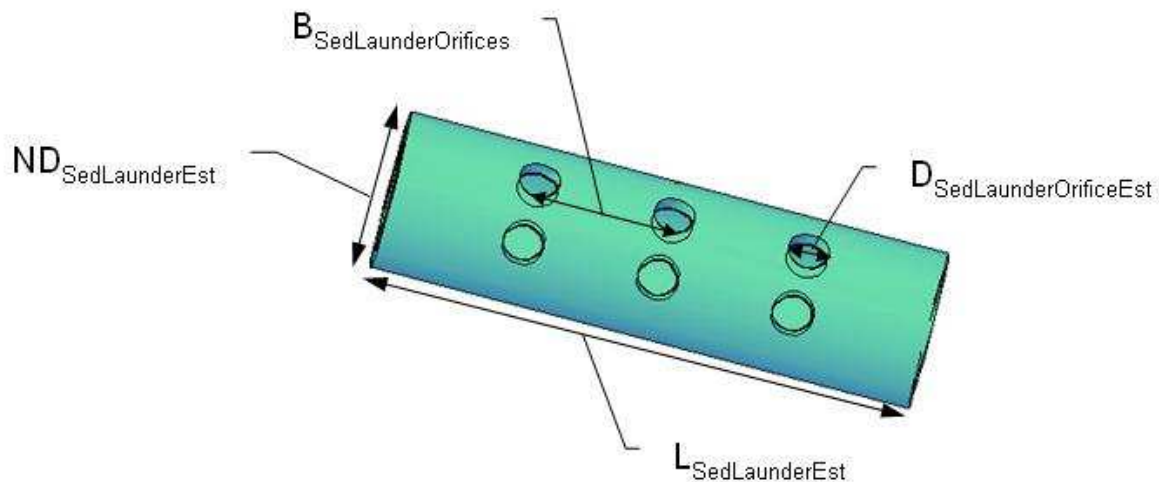

Figure 12: Effluent Launder Design

6. Exit Channel

The exit channel transports the water from the sedimentation tank, via the launder, and out of the plant. Chlorine is added to the water at the end of the exit channel and flows through the outlet weir. The outlet weir controls the flow to the storage tank and determines the water level throughout the entire plant. The exit channel is very similar to the design of the inlet channel in layout, but different in functionality.

The following are the dimensions for the exit channel.

Dimension	MathCAD Variable Name	
Width	$W_{ExitChannel}$	0.208m
Height	$H_{ExitChannel}$	0.563m
Length	$L_{ExitChannel}$	2.14m

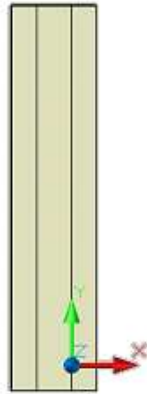

Figure 13: Exit Channel – Top View

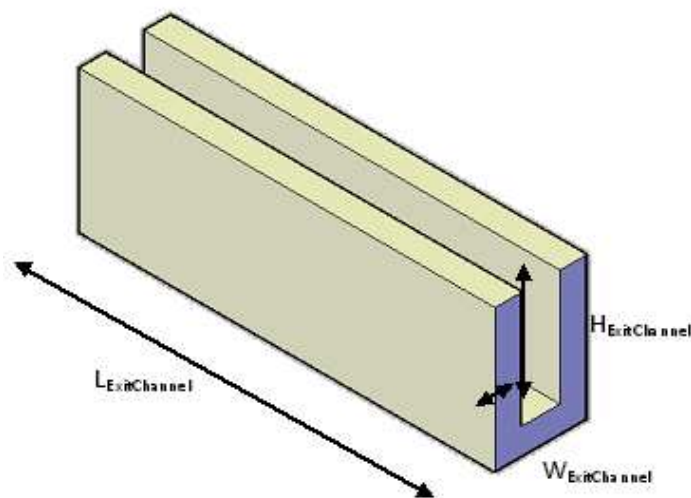

Figure 14: Exit Channel – Isometric View