

Filter Constrictions, Spring 2017

Jillian Whiting, Janak Shah, and Samantha He

August 8, 2017

Abstract

The goal of the Filter Constrictions Team was to test the hypothesis that particles are captured preferentially at flow restrictions in sand filters. There was evidence for this from work done by the Milli-Sedimentation Team and the Stacked Rapid Sand (StaRS) Filter Theory Team. The goal of the team was to create a flow constriction in a 0.5 mm channel in a flow cell reactor, and take a video of the particles at the constriction. The video was taken using Point Grey FlyCapture Software, and provided evidence about the hypothesis that flow constrictions serve as particle collection sites.

Introduction

The Filter Constriction was a new team created to determine whether the hypothesis that particles are captured preferentially at flow restrictions in sand filters is accurate. At flow restrictions, streamlines converge and thus particles that are near the sand grain (the edge of a pore) move closer to the edge at the contraction. This results in an increased rate of deposition of flocs at the constriction. As more particles collide with each other and build up at the constriction, the velocity through the restriction increases until the particles can rotate sufficiently to pass through the constriction.

The theory was tested using a flow cell reactor. The flow cell reactor was designed using a PVC block and creating a channel 0.5 mm deep at the top of the block. The flow constriction was 0.3 mm, and created a 0.2 mm channel by the constriction for particles to flow through. The camera was then used to capture what occurred at the constriction. If the camera captured particles depositing on the flow restriction, this would provide strong evidence for the filter constriction theory. This would allow AguaClara to continue to pursue work with this hypothesis in terms of filtration.

Literature Review

Minor head loss happens when streamlines are suddenly separated by the change of flow area, shown in Figure 1. Though it is not significant when compared to the energy loss caused by friction, the team considered it as a main form of energy loss because of the design of the apparatus. In the apparatus, the flow restrictions cause the streamlines to converge and thus particles going through move closer to the edge of the contraction. This results in accelerated deposition of particles before or right at contractions, which causes the contraction to decrease in size. As particle collisions continue to be more and more frequent at the contraction, eventually the velocity through the constrictions increases to the point where the drag on particles that collide with the constriction is sufficient to rotate the particle through the constriction so that attachment does not occur (Weber-Shirk, 2017).

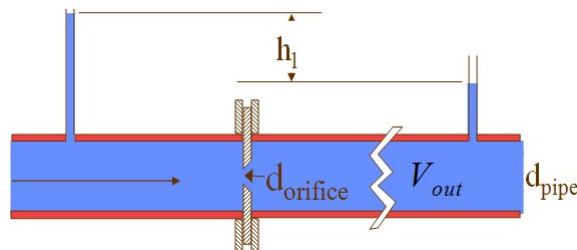

Figure 1: Minor head loss occurs when there is a constriction. In Filter Constrictions Spring 2017 team's design, minor head loss dominates head loss. So, h_l equals to h_e in this case.

Previous Work

The Milli-Sedimentation Team in Fall 2016 tested whether using coffee straws would improve the efficiency of sedimentation and filtration by combining the two processes (Whiting et al., 2016). The straws were arranged in a honeycomb similar to the design of conventional tube settlers. When the length of the tank was increased, there was a constriction created because the honeycomb arrangement of the first set of tubes did not align with that of the next set of tubes, thus creating a small gap between the straws. The team observed that there was a high density of flocs at the constriction. The Milli-Sedimentation team then created three constrictions in the tank as shown below in Figure 2.

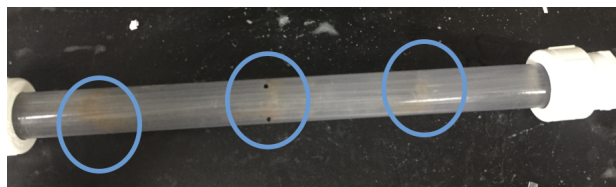

Figure 2: The constrictions in the the milli-sedimentation tank were where the flocs congregated. The first constrictions had the highest concentration of flocs, followed by the second and the third constrictions.

The highest density of flocs occurred at the first of the three constrictions. The team determined that constrictions created between straws had high concentrations of flocs. This is because flocs were more likely to collide with one another at the constriction. This also increased particle removal efficiency.

The Stacked Rapid Sand Filter Theory team, hereby referred to as StaRS, has worked on developing a model on how StaRS Filters work (Chu et al., 2016). Their goal was to determine a mathematical model for filter performance to match with the data that they collected from their sand filter. The team developed a constriction model for how flocs are removed. This model predicts that flocs will be preferentially filtered out at constrictions. This is because, at a constriction, the streamlines come closer together and therefore flocs are more likely to collide with each other and the “walls”, or sand particles. A sample constriction in a sand filter is shown below in Figure 3.

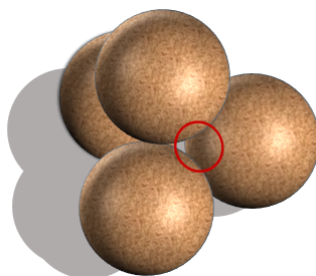

Figure 3: This is a model of three sand particles creating a constriction shown in red. The streamlines converge in this constriction and flocs will be preferentially filtered out at this spot.

Methods

The team worked on designing the flocculator, flow cell, and experimental set-up in order to move ahead with their experimentation. The team has been through many iterations to determine the best way to fabricate a watertight flow cell. The first iteration was to use tape between PVC and acrylic glass. The next option used a curing silicone glue between PVC and glass. The team also experimented with a non-curing silicone glue and clamps. The final design was a silicone sheet secured by screws between two layers of acrylic glass. Below are the calculations for the team’s design requirements.

Experimental Apparatus

Preliminary Flow Cell Design

The team constructed a flow cell with a restriction of flow from the depth of 0.5mm to 0.2mm . This constriction was created by inserting a 0.3mm wire across the flow cell. The team designed the velocity in the flow cell to be the same as the velocity in the pore of a filter. The velocity in a filter is $\frac{1}{6}$ of the backwash velocity, $v_{backwash}$. AguaClara uses a backwash velocity of 11mm/s . The velocity through the pore, v_{pore} , is then the velocity through the filter divided by the porosity, ϕ .

$$v_{pore} = \frac{1}{6} * \frac{v_{backwash}}{\phi} = 2.82 \frac{\text{mm}}{\text{s}} \quad (1)$$

The flow rate, Q , can then be calculated as the cross sectional area multiplied by the velocity, v_{pore} . The depth of the flow cell is 0.5mm and the width, which is constrained by the bit size to drill the flow cell, is $3/8\text{in}$.

$$Q_{pore} = v_{pore} * A_{pore} = 4.48 * 10^{-3} \frac{\text{mL}}{\text{s}} \quad (2)$$



Figure 4: This is the 3D view of the design of the flow cell that the team planned to run experiments with. Flocculated water flows in through microtubing in the first hole, passes through the constriction, shown by a dark line, and exits out the second hole. A glass slide covered the flow cell channel to allow for a clear view of the surface.

Flow Cell Designed with Tape

The team initially constructed the flow cell using tape to create the 0.5mm depth. Three layers of 3M Double Sided Tape were attached on one side of a PVC block as shown in Figure 5. The team then measured the dimensions of the flow cell on the tape. An X-Acto knife was used to cut the tape from the flow cell at these dimensions. The three layers of tape gave the flow cell the desired depth of 0.5mm . The constriction was created using 0.3mm wire and was attached at $2/3$ of the length of the channel by cutting the wire to the same width of the channel. The top layer of tape was then removed and an acrylic slide was placed on the flow cell channel. Acrylic was used instead of glass due to the availability of acrylic in the lab.

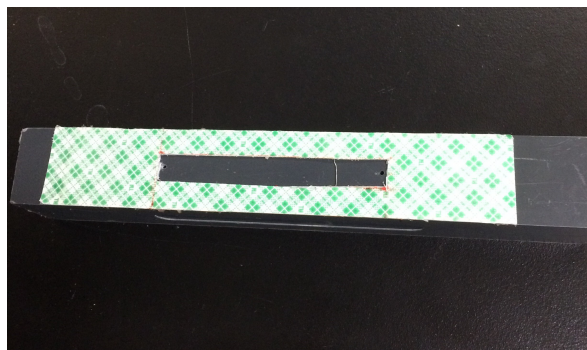

Figure 5: This is the top view of the design of the flow cell that the team ran experiments with. Flocculated water flows in through microtubing in the first hole, passes through the constriction, shown by a dark line, and exits out the second hole. The location of where the microtubing is inserted was shown. The location of the screws to keep the glass slide in place was also shown.

Silicone Glue Design

Since the taped flow cell was not watertight, the team went back to the original design of the flow cell that did not involve tape. The team decided to use silicone glue, which was accessible in the shop, instead of tape due to its watertight characteristic. Figure 6 is the top view of the new design involving silicone glue. The flow cell channel had already been constructed on the adjacent side of the PVC block at the beginning of the design process. The team glued a new constriction wire at the 2/3 point of the channel and inserted microtubing at the holes at the beginning and ending of the channel as before. In order to attach the acrylic slide to the plastic flow cell, the team applied clamps after applying glue for 24 hours as shown in Figure 7.

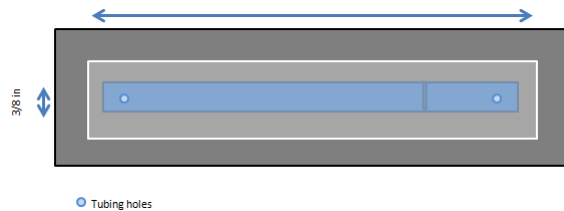

Figure 6: This is the top view of the design of the flow cell that the team ran experiments with. Flocculated water flows in through microtubing in the first hole, passes through the constriction, shown by a dark line, and exits out the second hole. The location of where the microtubing is inserted was shown.



Figure 7: This is how the team used clamps to attach the acrylic to the PVC. This allowed for pressure to be evenly distributed across the flow cell during the drying period.

This method was later changed due to a fissure on the inlet microtubing. The team removed the acrylic slide cover and remade the flow cell. In order to ensure the attachment, the team covered the channel edge with silicone glue carefully and fixed the acrylic in clamps for 24 hours. The extra piece of PVC was used to prevent the acrylic from being scratched. In addition, the team drilled two mini culverts along the way of the tube going out from the holes as shown in Figure 8 to avoid the sudden and sharp bent of the microtubing. A piece of wood was attached to the non-acrylic side of the flow cell when clamping to prevent potential microtubing damage.

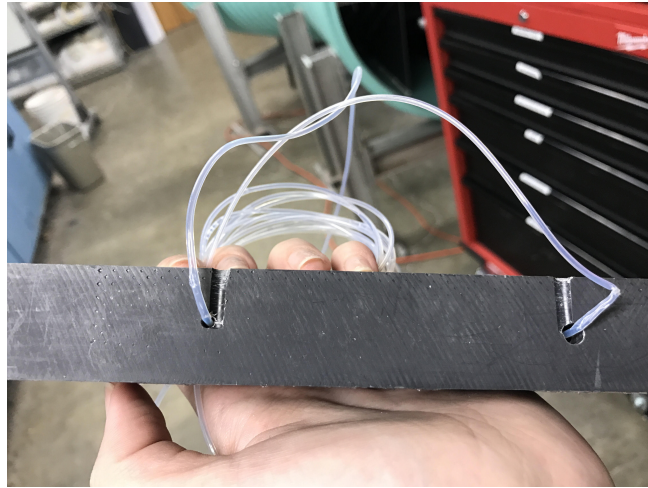

Figure 8: Culverts were created to avoid fissure of microtubing. When the flow cell was clamped for the drying period the microtubing bent slightly around the culvert instead of at 90 degree angle which creates fissures.

Silicone glue was an ineffective watertight sealant. Thus, new sealant was used as shown in 9. This glue provided a moisture barrier that did not dry. Thus, the glue did not require a 24 hour period before the flow cell could be tested. Rubber bands were used to create a seal for the acrylic slide.



Figure 9: The alternate sealant was used to attempt to create a watertight seal.

The previous attempts to design the flow cell all failed to create a watertight seal. Thus, the team redesigned the flow cell. A silicone sheet was applied in the new design, shown in figures 10, 11, and 12. In order to create a watertight seal with the silicone, pressure was applied on it. The pressure was only applied in the axial direction as not to create any horizontal movement between components of the design. The bottom piece of the design is made of acrylic so that the apparatus could be back lit during experiments.

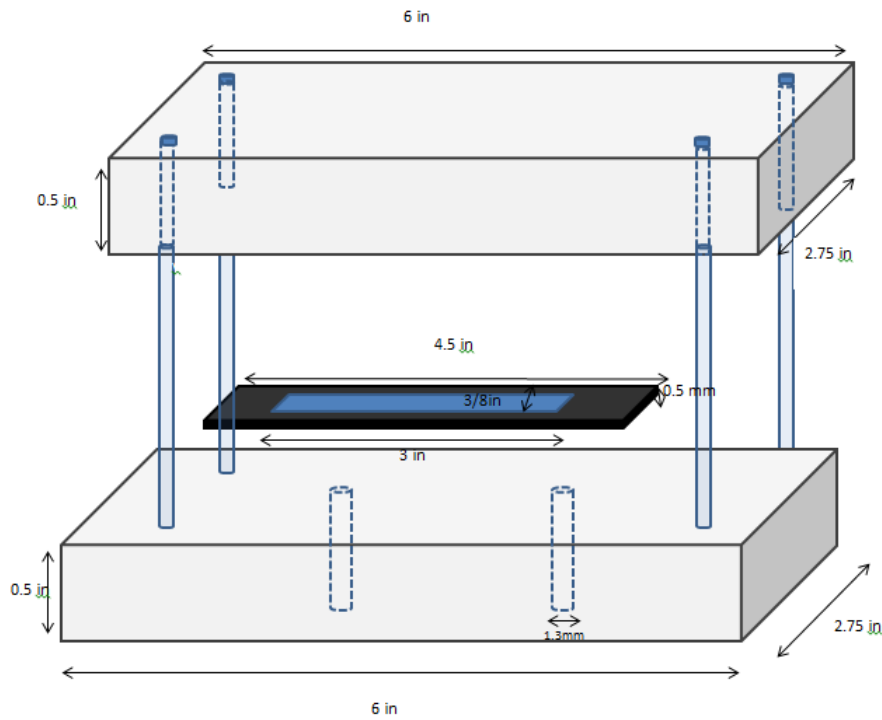

Figure 10: The top component of the flow cell is made from acrylic which provides a window for viewing into the flow cell. This is screwed together with the bottom layer of acrylic which is the same size. This is clear so that the flow cell can be lit from the back. The bottom acrylic also has two hole drilled in it for the microtubing to go into which will take water to and from the cell. The second layer down is made of glass which is pressed against the third layer of silicone rubber by the screws. The silicone layer has it's center cut out in them dimensions of the flow cell. Two-thirds of the way though the flow cell that is cut out of the silicone sheet there is a wire to create a constriction. This creates a water tight flow cell for the flocs to flow through that can be viewed from one side and light can go through the other.

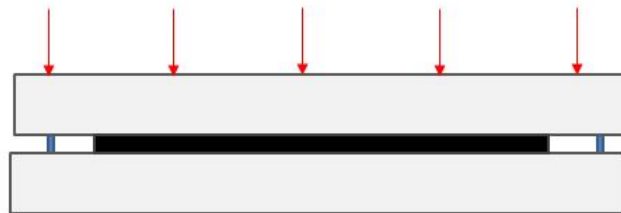

Figure 11: This is the side view of the flow cell. It shows that when screwed together all components of the flow cell will have pressure on them and lay flush with each other. This will create a water tight seal around the flow cell. The red arrows indicate where the screws were inserted.

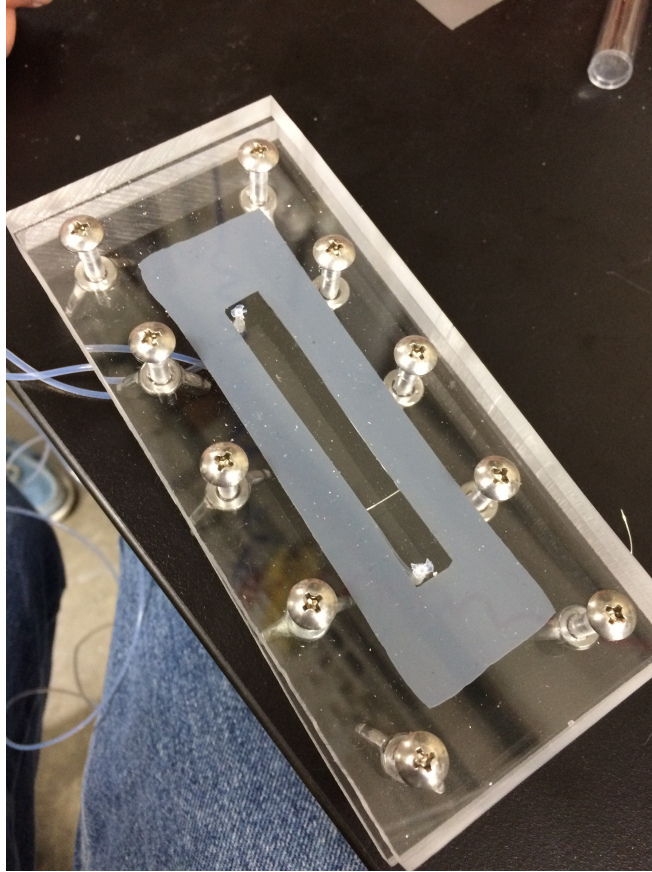

Figure 12: This is the fabricated flow cell with screws attached to connect the acrylic blocks together. The flow cell was created by cutting a channel of proper dimensions in the silicone rubber sheet. The constriction wire was placed $3/4$ of the way down the channel. Screws were used at various places to ensure a stable attachment of the acrylic blocks.

The flow cell was positioned as shown in Figure 13. This position allowed the camera to be focused on the constriction to provide a clear view of how flocs behaved at the constriction.

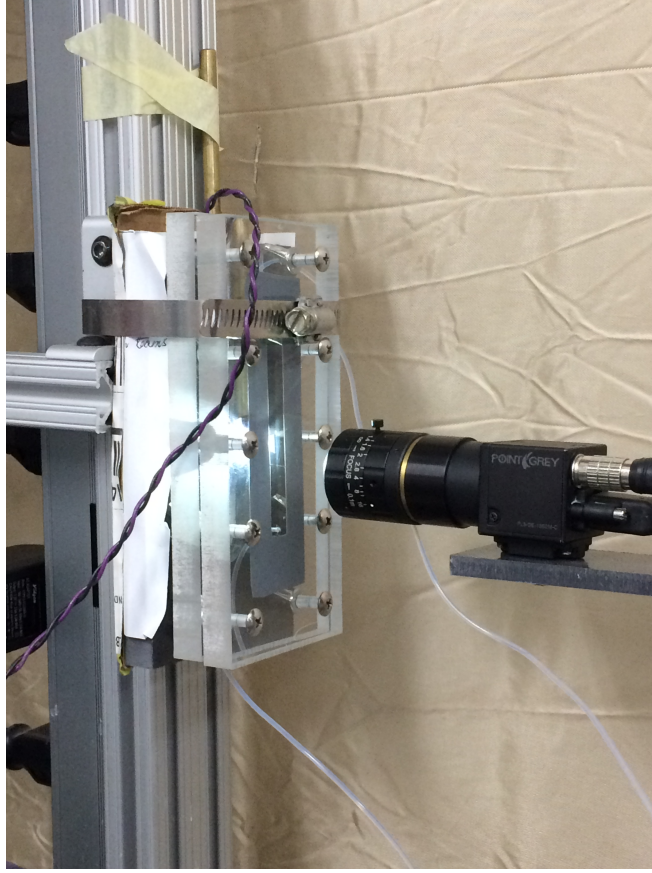

Figure 13: The flow cell was mounted on top of a PVC block that was cut out to allow the light source to be inserted and cardboard/white paper to block the 80-20 from the camera's view. The camera was mounted on top of a PVC block that was attached to an 80-20. The camera was positioned and adjusted so that the lens was on top of the constriction. The LED light source was placed in the hole created by the PVC block and taped in place to backlight the flow cell channel.

After running experiments under such setup, the team determined that back-lighting the flow cell was ineffective for observing what occurred at the front of the wire, as the wire blocked light. But back-lighting did provide a clearer view of the flocs. Thus, the team kept this setup for a while before switching the light source to the front, which allowed the team to observe the front floc activity.

Flocculator Design

The team designed a flocculator with $0.6m$ of headloss and a 1 minute residence time as shown in Figure 14. The energy dissipation rate, ϵ can therefore be calculated by using equation 3, where θ_{Floc} is the residence time, h_{Floc} is the headloss, and g is gravity.

$$\epsilon_{Floc} = \frac{h_{Floc} * g}{\theta_{Floc}} = 99.7 \frac{mW}{kg} \quad (3)$$

From energy dissipation, the $G\theta$ can be calculated using equation 4 where ν is the kinematic viscosity of water.

$$G\theta = \theta_{Floc} * \sqrt{\frac{\epsilon_{Floc}}{\nu}} = 18950 \quad (4)$$

The length of the flocculator can be calculated using equation 5, where Q_{Plant} is the flow rate of the overall apparatus and D_{Tubing} is the diameter of the tubing used for the flocculator.

$$L = \theta_{Floc} * \frac{Q_{Plant}}{(\pi * D_{Tubing}^2)/4} = 11.45m \quad (5)$$

The maximum size of the flocs created can be calculated using equation 6.

$$D_{FlocMax} = 95\mu m * \left(\frac{W}{\epsilon_{Max} kg} \right)^{1/3} = 0.205mm \quad (6)$$

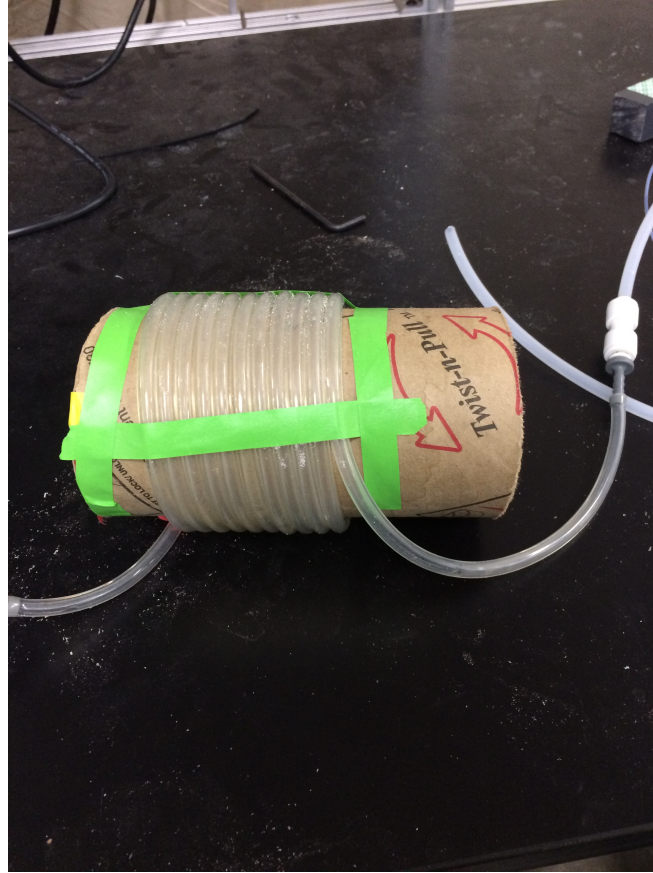

Figure 14: This is the flocculator the team designed to the specifications of 0.6 m headloss and a 1 minute residence time. The length of tubing used was 11.45 m.

Flow Diversion Design

The flow rate needed to create the required head loss is much larger than it was desired in flow cell. Therefore, the team needed to apply some t-connectors to split the flow outgoing from flocculator to decrease the flow rate entering the microtubing connected to the designed flow cell. Equation 7 shows that the amount of flow diverted through each tube is proportional to its cross sectional area. The microtubing has a diameter of 1.067mm and the regular tubing has a diameter of 0.25in.

$$Q_{tubing} = Q_{pore} * \frac{A_{tubing}}{A_{microtubing}} = 0.46 \frac{mL}{s} \quad (7)$$

This flow rate was not enough to produce 0.5m of headloss so the flow was split more times. However, it did not need to be split to the magnitude that the difference in size between microtubing and tubing creates. Instead, the team used 2 addition splits shown in Figure 15 with 1/4in tubing on both sides to split the flow in half. This creates a overall plant flow rate of 1.84 $\frac{mL}{s}$.

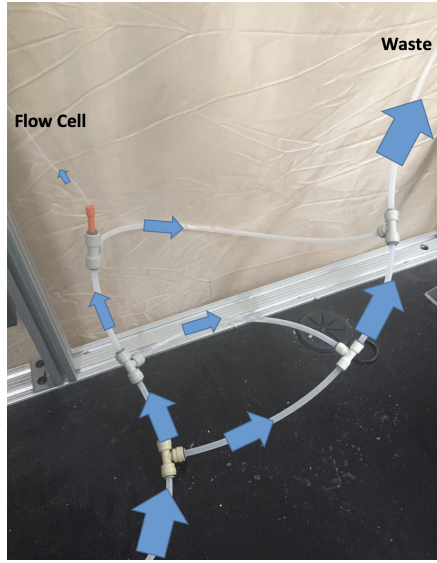

Figure 15: This set-up creates flow diversions so that the entering flow is $1.84 \frac{mL}{s}$ and the flow going into the flow cell is $4.48 * 10^{-3} \frac{mL}{s}$. This is created by the three t-connectors shown with the flow splitting shown by the arrows. The first two diversion split the flow equally while the last diversion splits the flow according to the cross-sectional area of the tubing.

Schematic

The water flows through out apparatus as shown in Figure 16 below. The clay concentration in the apparatus was $5 NTU$ and the concentration of coagulant was $0.7 \frac{mg}{L}$. Peristaltic pumps create a pulsating flow, which would interfere with the flow cell design, so the system was designed to have over $2.5m$ of headloss to counteract the pulsating. This was created by sending the effluent water of the flow cell back to the inlet pipes at the ceiling, using a T-connector to open the flow up to the atmosphere, and then sending the flow back down into a bucket.

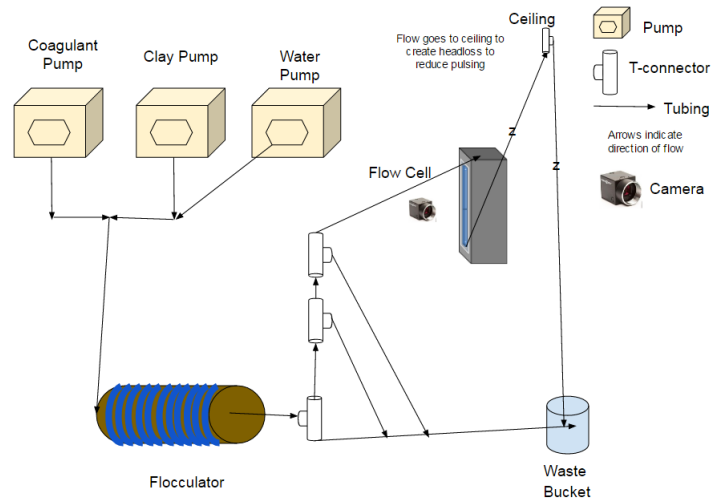

Figure 16: Water and a clay solution are pumped together and coagulant is pumped into the system separately. They are combined and then flow through a flocculator in order to make flocs. Some of the flow is then diverted through the flow cell, while the rest flows into a bucket. The flocculated water that goes through the flow cell is what is recorded by the camera. The water exits the flow cell and flows through microtubing to the ceiling to create headloss, and then flows down into a bucket. The water is then pumped from the bucket to waste.

Results and Analysis

Failure of Tape Design

The flow cell designed with tape was initially tested to determine the viability of the design. The flow cell was attached to the apparatus as in Figure 16. When water was run through the apparatus, the flow cell leaked from the sides of the channel as well as the bottom of the channel. Thus, it was determined that using tape to attach the glass slide was not a viable design as it did not provide a water-tight seal. This resulted in the team searching for other methods of attaching the glass slide that did not cause water to leak from the flow cell.

Silicone Glue Design

After 24 hours, the clamps were removed from the flow cell and the apparatus was re-constructed as shown in Figure 16. When water was run through the apparatus, water leaked through the holes on the side of the PVC block. This was due to a break in the microtubing inside the PVC block. This allowed water to leak into the block and thus into the perpendicular hole drilled from the previous experimental design of the flow cell that utilized tape. Some water also leaked out of the side of the acrylic slide, which indicated that the silicone glue was ineffective as a water-tight seal. However, this also may have been due to error with applying the glue to the PVC block as well with clamping the acrylic slide to the block as the slide shifted when glue was applied. Thus, the glue was used again but by correcting these experimental errors.

After keeping the flow cell in the vice clamp for 24 hours, the microtubing was found to be ruptured where the rough edges of the vice were clamped to the tubing. The silicone glue was also applied so that glue covered the hole for the microtubing to enter the cell. Thus, water was not able to pump through the flow cell. When glue was reapplied, it was done more carefully to avoid covering the microtubing. The tubing was also intact due to the culverts drilled at the bottom of the flow cell. However, the acrylic slide shifted once more when applied to the flow cell and was not watertight when water was run through the apparatus.

The moisture barrier provided by the alternate silicone sealant was ineffective as a water tight seal. Water leaked from the flow cell channel through sections where the sealant was not as well applied. The failure of this sealant led the Filter Constrictions team to explore a new option for fabricating the flow cell.

The first attempt to test the design using the silicone rubber sheet as well as acrylic blocks was unsuccessful. The screws were not attached tightly enough, and water leaked from where microtubing was entering through the flow cell. This indicated that the screws needed to be more effectively tightened and that the microtubing at the entrance of the flow cell channel had to be re-stretched to ensure that water did not leak out of the flow cell. After addressing these issues, the flow cell was found to be watertight when water was run through it. Thus, this design was determined to be an effective design to run flocs through.

After running several trials, the team successfully recorded videos indicating the movement of flocs. Video of the floc being captured can be found at : [Floc Capture](#) Streamlines formed when team run the experiment under 50 NTU inflow water. Bigger flocs stuck at the constriction while smaller ones passing through with several attaching to the front of the wire. As more and more floc attached to the wire, streamlines became more irregular and highly curved because the water was diverted to go around where the flocs had attached, as shown in figure 17. Video of the streamlines can be found at: [Streamlines](#).

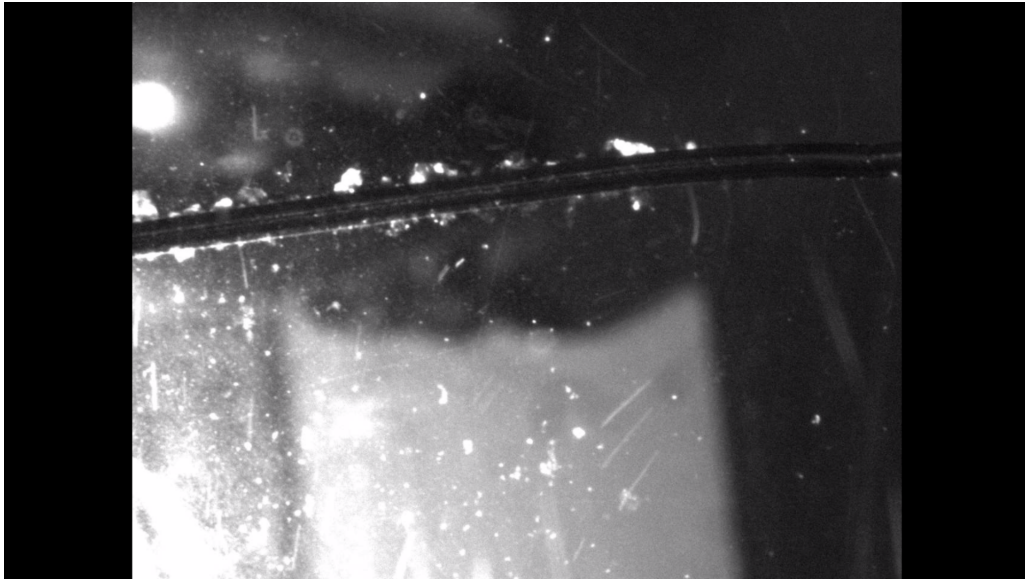

Figure 17: The pathways of flocs passing through constrictions is clearly the typical streamlines.

The team also saw flocs deposit both on top of the wire and in the middle of the wire. According to StaRS theory, the flocs should deposit at the center of the wire where the constriction is the smallest. There are two reasons that flocs could have deposited on top of the wire. The flow creates eddies behind the wire that impact floc deposition or that flocs have already accumulated in the center of the wire and these flocs are accumulating on top of existing flocs.

Conclusions

A video of flocs at the constriction was captured through both back-lighting and front-lighting the flow cell. Larger flocs appeared to deposit the wire, and it was revealed when front-lighting the flow cell that some flocs attached to the middle of the wire. Thus, it is shown that particles preferentially deposit on the wire, specifically on the middle of the wire, but more videos must be taken to fully validate the hypothesis.

Future Work

The future tasks Filter Constrictions team will include continuing to run experiments and record videos of flocs at the constriction. The team will also experiment with effective ways to front-light the flow cell to observe how flocs behave on the middle of the constriction. Another future task would be to use a semicircular wire as a constriction rather than a circular wire to prevent flow from circling back behind the wire. Angling the camera so a side view of the constriction is another future goal, as this would allow the team to observe exactly where flocs deposit on the wire.

References

- Chu, T., Harris, J., Li, L., and Pennock, W. (2016). A Model for Stacked Rapid Sand Filters - Overleaf.
- Weber-Shirk, M. (2017). Flow Control and Measurement.
- Whiting, J., Shah, J., and Wang, T. (2016). Milli-Sedimentation, Fall 2016.

Semester Schedule

Task Map

Task Maps should be created in Microsoft Word and then copy and pasted into the Detailed Task List in Overleaf. Save your word document on Google Drive so that you can make adjustments later in the semester. To Create one, open Microsoft Word. Under Insert, go to Smart Art, click Hierarchy, then Horizontal Hierarchy. Click the arrows on the left side of the box to open up a bulleted list of how your Map is organized. Make sure your map is as large as possible on the page (it may be necessary to increase the font size), then copy and paste it into the Google Doc.

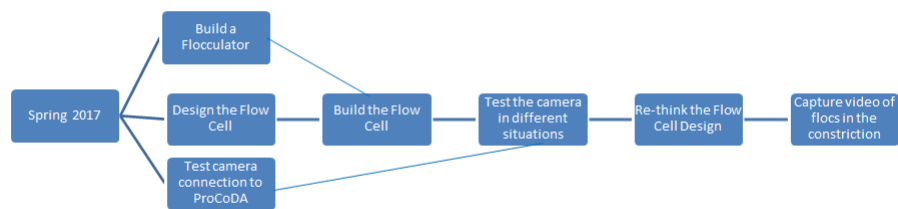

Figure 18: The task map for the Filter Constrictions team for the 2017 semester

Task List

You should keep and update your detailed task list from the first assignment in each of your reports. Denote completed tasks and modify your deadlines to reflect your most recently completed progress and any delays.

1. **Build a Flocculator (Jillian)-2/14:** Design and construction a flocculator that has 50 cm headloss and a 1 minute residence time. -Completed
2. **Design the Flow Cell (Janak) – 2/28:** Design a flow cell that has one constriction from about 0.5 mm to 0.3 mm. It should be glass on one side for the camera and black on the others. -Completed
3. **Test Camera (Samantha) – 3/14:** Test camera and see if we can control it with ProCoDA. Make sure it has enough pixels to see flocs. - Completed
4. **Build the Flow Cell (Jillian) 3/14:** Construct the flow cell and test it with water to make sure it doesn't leak and the constriction restricts all flow - Completed
5. **Test the camera in different situations (Janak) 3/31:** Test the camera with flocs to make sure it can capture them and we can see when they are deposited (possibly try with red dye if regular flocs don't show up)- Completed
6. **Re-think the Flow Cell Design (Samantha) 4/15:** Change any aspect of the flow cell that makes the video not work- Completed
7. **Capture video of flocs in the constriction (Jillian) 5/11:** Take a good quality video that shows what happens to flocs in a constriction- In Progress

Report Proofreader: Janak Shah

Manual

Experimental Methods

Standard Operating Procedure

Beginning a Test

1. Open Blue (Clean water) and Red (Waste) valves by turning valves 90 degrees counterclockwise so that they are parallel.
2. Turn on all pumps and make sure they are running the the clockwise direction
3. Make sure Clay and Water Pumps are on mA mode
4. Make sure Coagulant Pump is on INT mode
5. Turn ProCoDA to Automatic Operation and change the state to RUN
6. Turn the Coagulant Pump to 28.8 RPMs
7. Make sure Camera is connected to the computer
8. If it does not show up, Force Camera to IP
9. Start Video on Point Grey FlyCap Software
10. Ending a Test
11. Clay and Water Pumps should turn off automatically
12. Turn off Coagulant Pump
13. Close Blue (Clean water) and Red (Waste) valves by turning valves 90 clockwise so that they are perpendicular.

Cleaning Procedure

ProCoDA Method File

Use this section to explain your method file (.pcm). This could be broken up into several components as shown below:

States

- OFF: Resting State in ProCoDA, all pumps, sensors, and relay boxes are off.
- RUN: This is the state that turns on the stirrer and clay and water pumps, and it runs for the run time.

Set Points

- ON
- OFF
- Water Pump Flow Rate: 1.79 mL/s
- Water Pump Tubing Size :17
- Clay Pump Flow Rate: 0.05 mL/s
- Clay Pump mL/rev: 0.149 mL/rev
- Run Time: 3600 seconds

Variables

- Water Pump: Runs the Water Pump at the 1.79 mL/s using size 17 tubing
- Clay Pump: Runs the Clay Pump at 0.05 mL/s using 0.149 mL/rev

Special Components

If your subteam uses a particular part that is unique and you could foresee a future subteam needing to order it or learn more about it, please include basic information like the vendor where it was purchased, catalog/item number, and a link to any documentation. For example, here is a link to the User's Manual for the model of turbidimeter most commonly used in AguaClara research.