

# Design

The Design Team facilitates communication between the research teams, the field engineers, and other AguaClara partners.

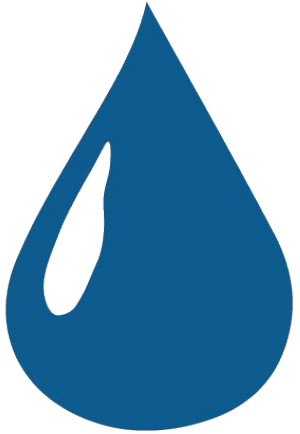



# CDC Updates

The drawing code for the Chemical Dose Controller and surrounding systems was completed to reflect current plant layout.

# The CDC system is a part of existing plants.

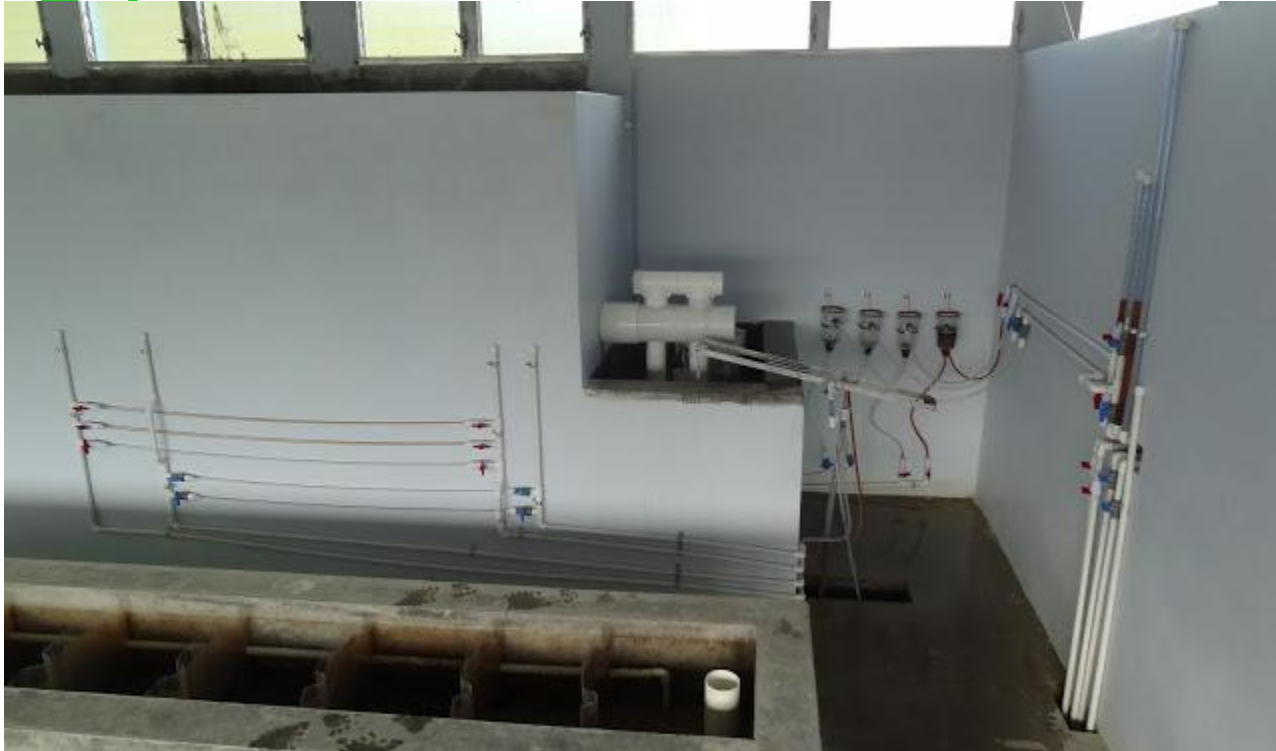

Figure 1: San Matias CDC

Additional drawing code was needed to complete the system in the ADT.

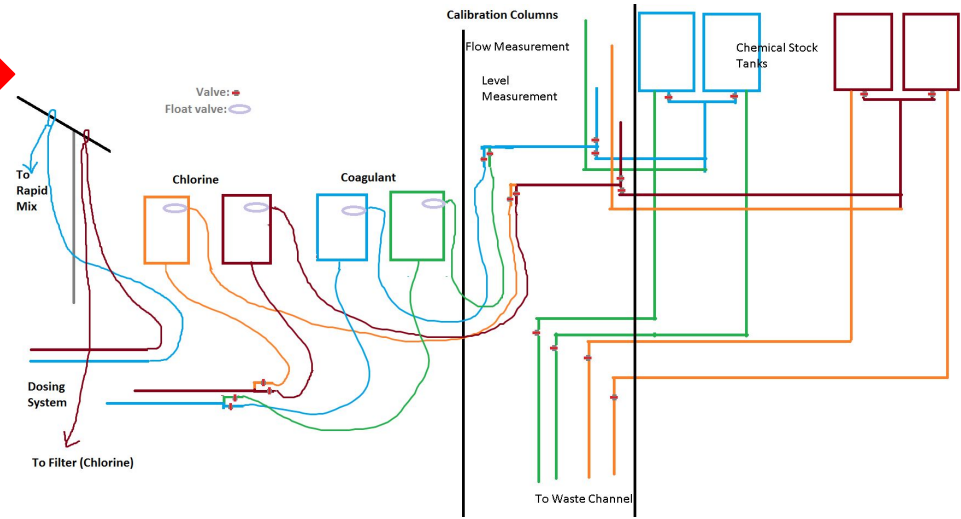
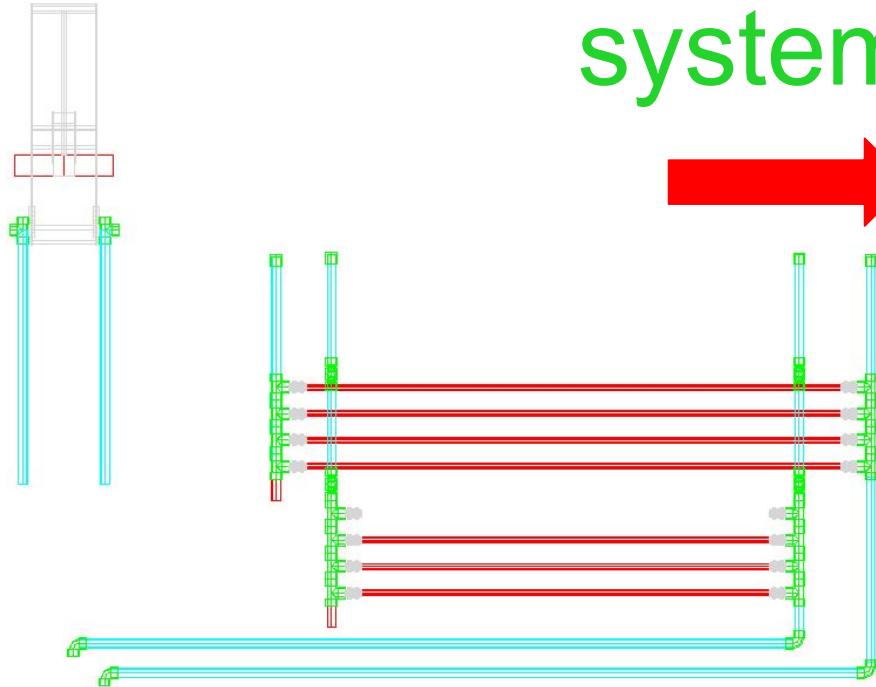
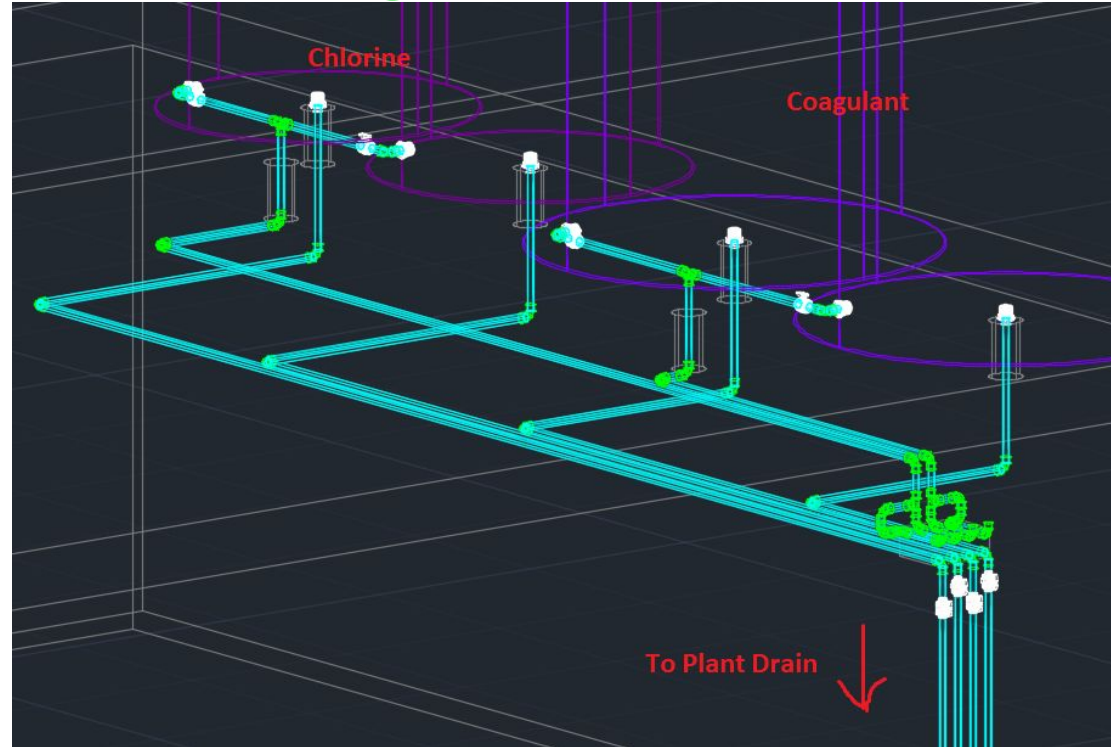

Figure 2b: A sketch of the additions needed.

Figure 2a: Current CDC System created by Serena in Fall 2015.

# The first component updated was the chemical storage tanks.

Figure 3: Connection plumbing from the chemical storage tanks to the calibration columns and chemical drains.



The next component updated was the CDC itself.

Figure 4: Parts of the system drawn in the CDC file.

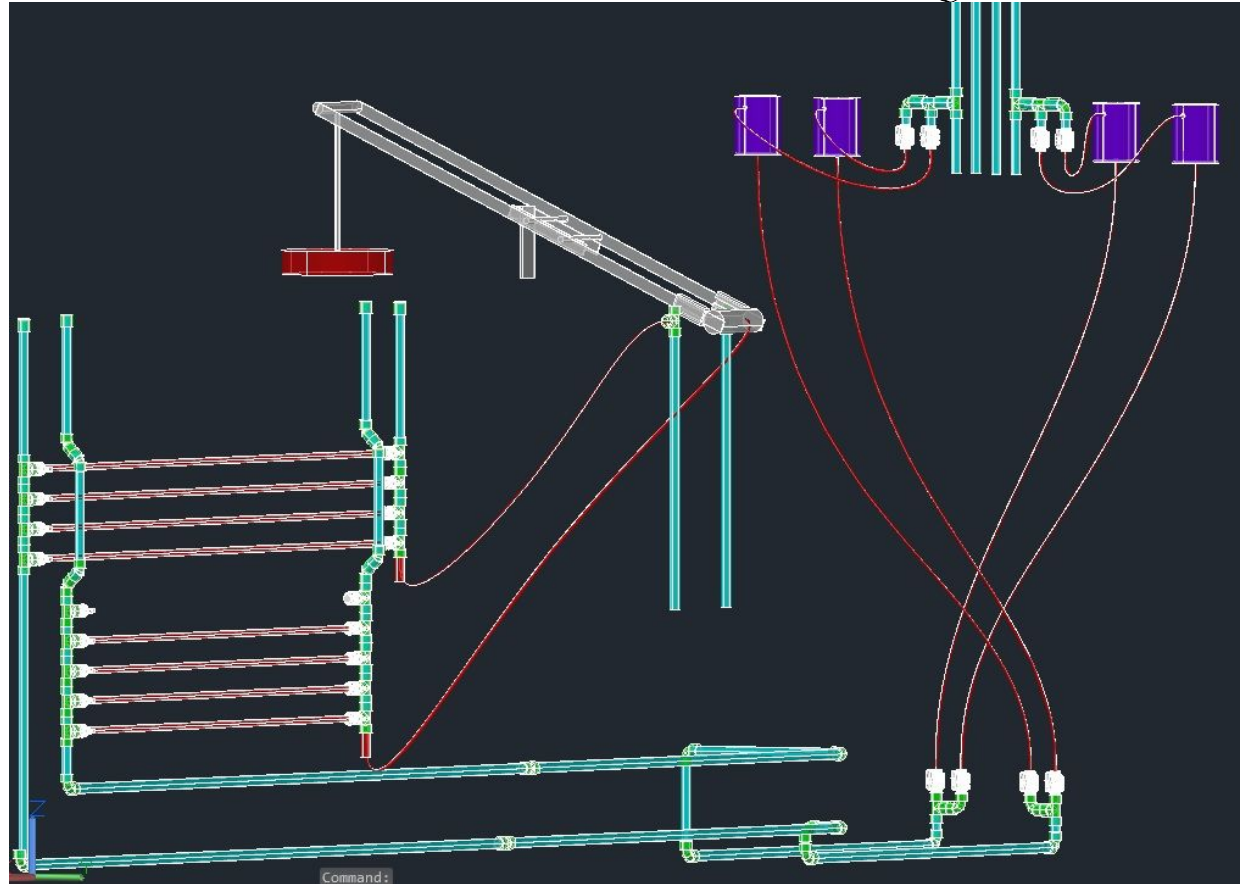

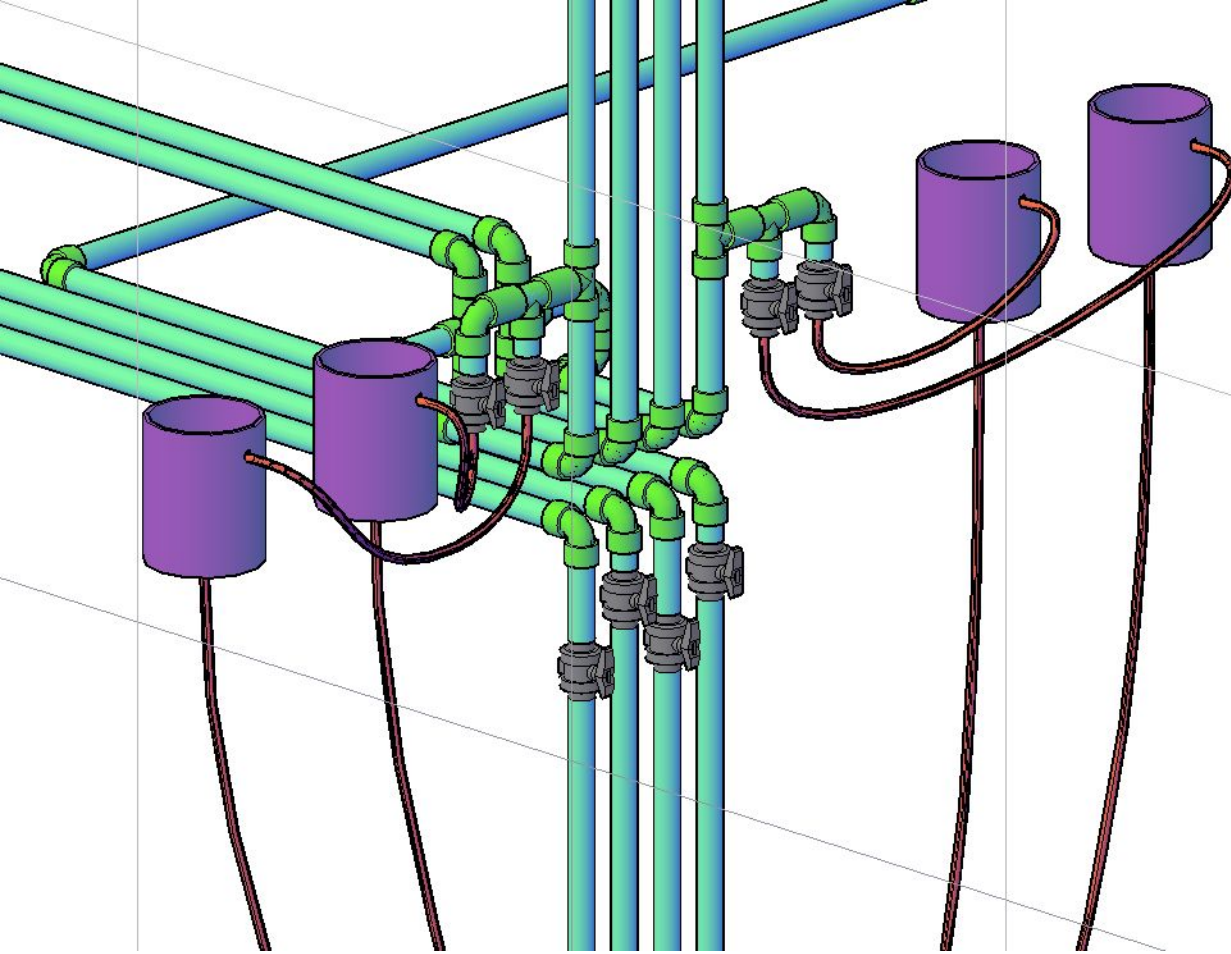

A significant addition to the CDC code was flexible tubing.

Figure 5: Flexible Tubing

The final component updated was the plant walkway.

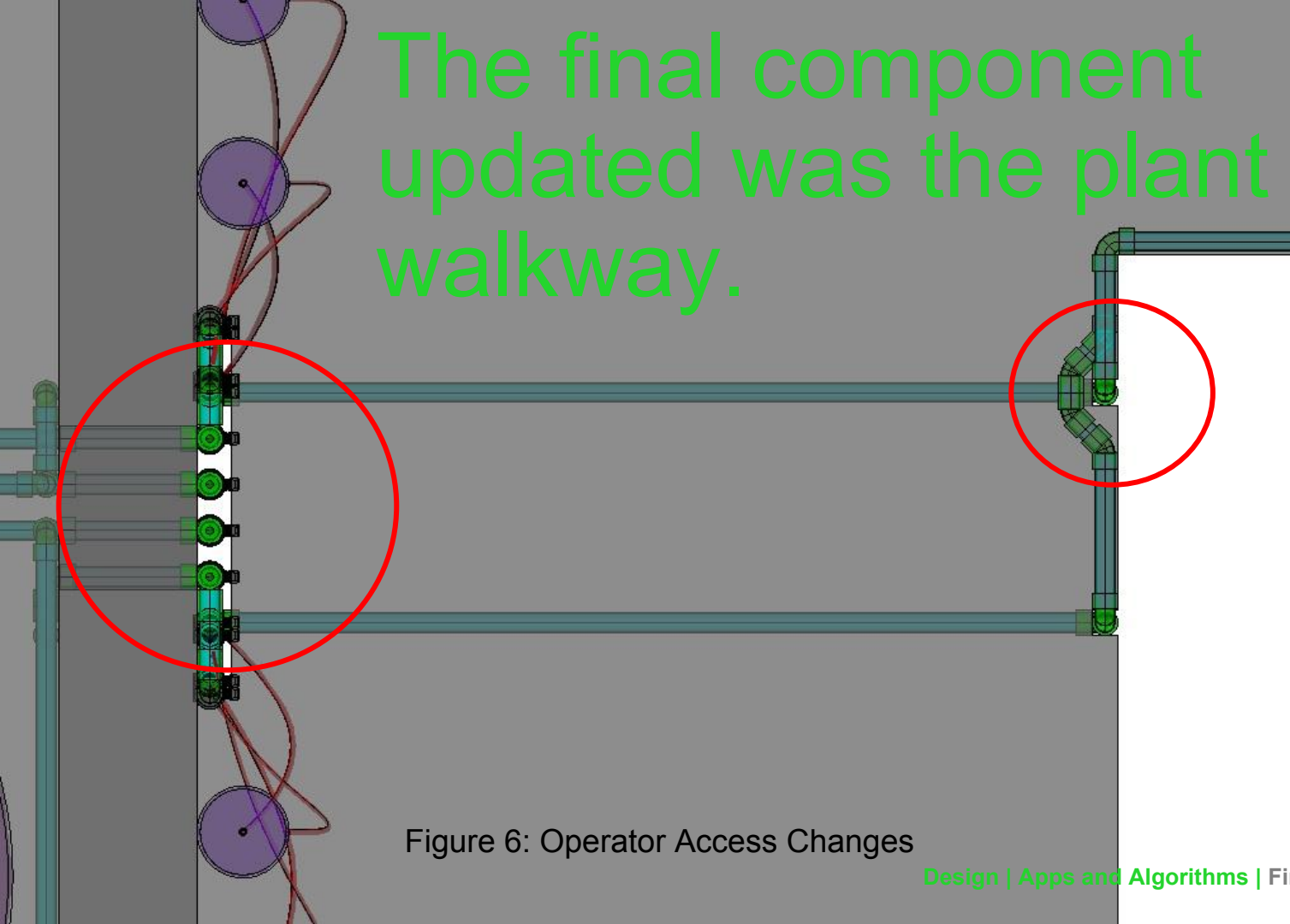

Figure 6: Operator Access Changes



The CDC  
system is  
not  
complete.

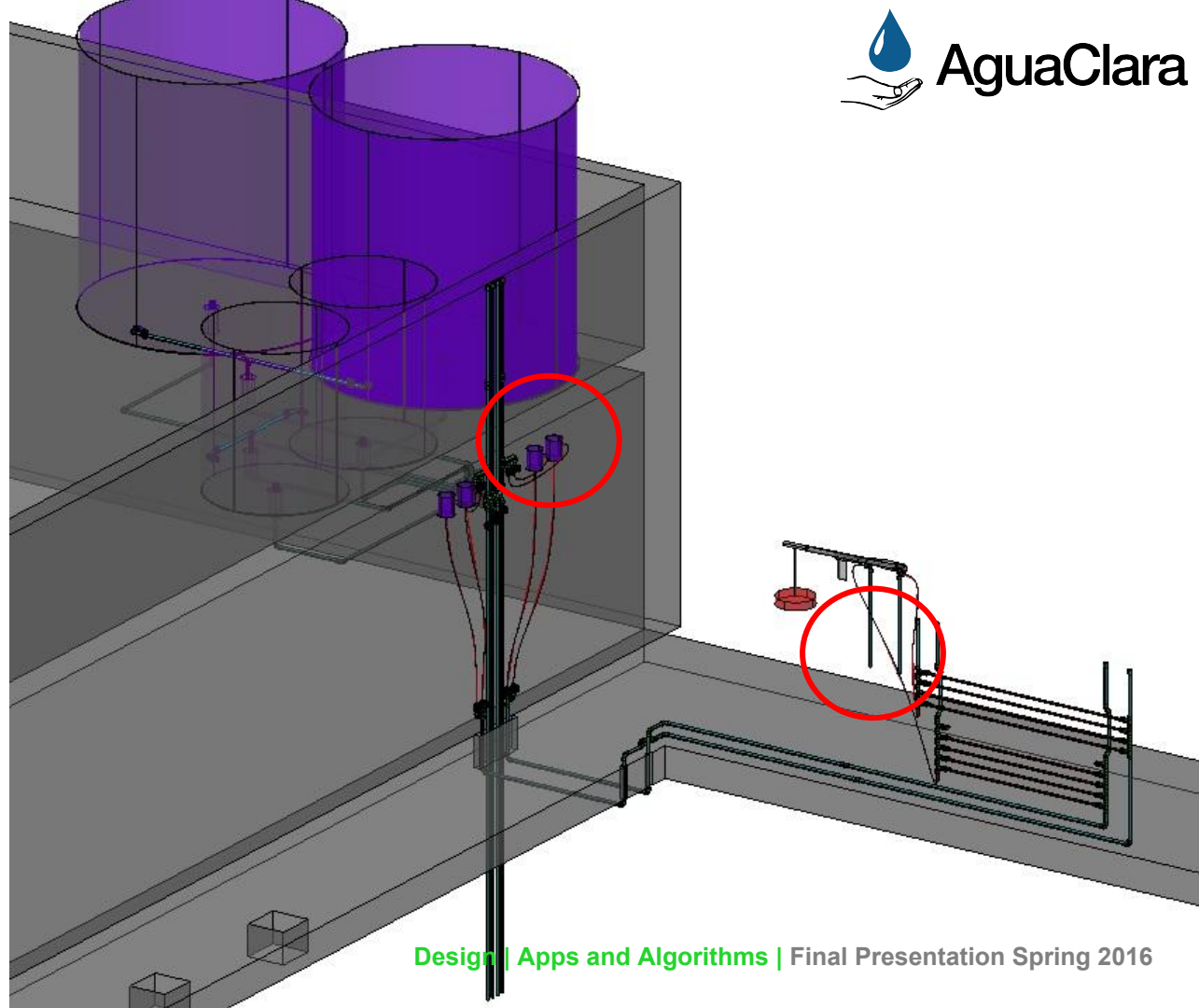

Figure 7: Areas in need of future work.

# Modular

The Modular team is a subset of the Design team whose main focus is to write the code for individual parts of the plant.

# Team



# EStaRS and OStaRS code were incorporated into one file.

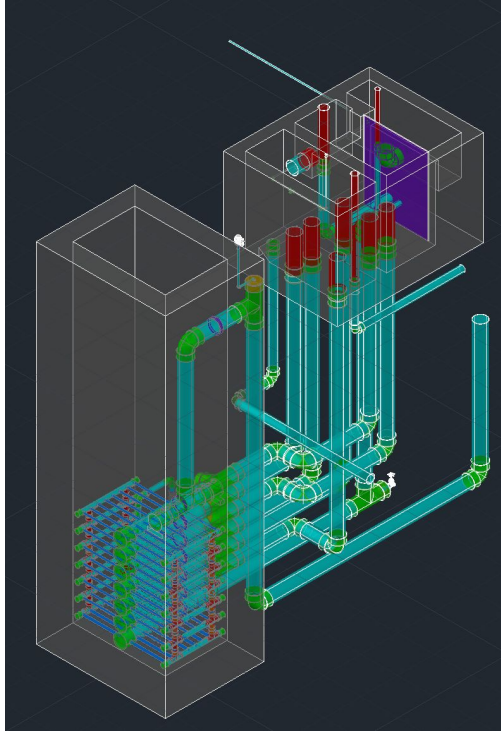

Figure 1: OStaRS filter

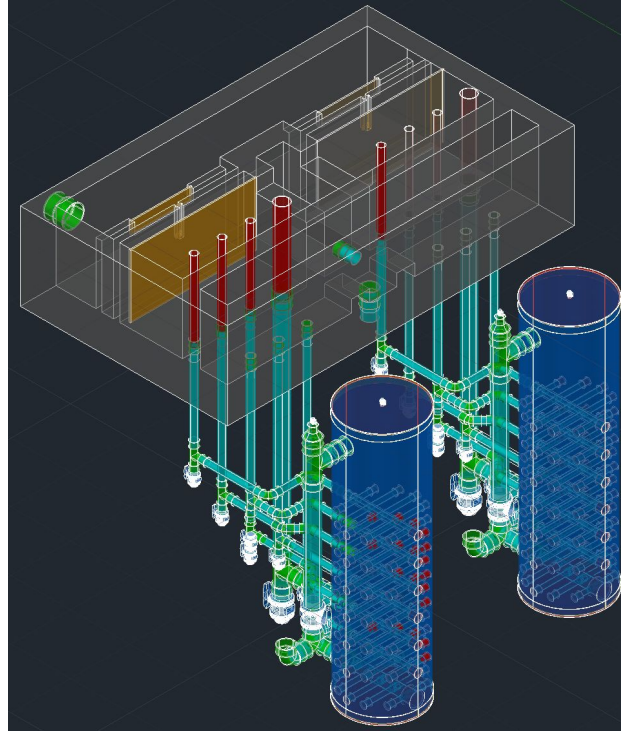

Figure 2: EStaRS filter

- Reference files and code for both EStaRS and OStaRS were placed in one master file.
- The output AutoCAD script was determined based on the plant flow rate.

# An if statement determined which filter would be drawn.

$$AC_{\text{Filter}} := \begin{cases} AC_{\text{FilterLow}} & \text{if } Q_{\text{Plant}} \leq Q_{\text{PlantMaxLF}} \\ AC_{\text{FilterHigh}} & \text{otherwise} \end{cases}$$

Figure 3: The if-statement that assigns  $AC_{\text{Filter}}$  the correct code based on flow rate

$Q_{\text{PlantMaxLF}}$  determines the flow rate threshold between producing an EStARS and OStARS design.

# Chemical Storage Tanks and CDC code were also written into one file.

- Reference files and code for both the CDC and Chemical Storage Tanks were placed in one master file.
- The blue pipes are part of a code that connects the Storage Tanks to the CDC. It is currently in the process of being written.

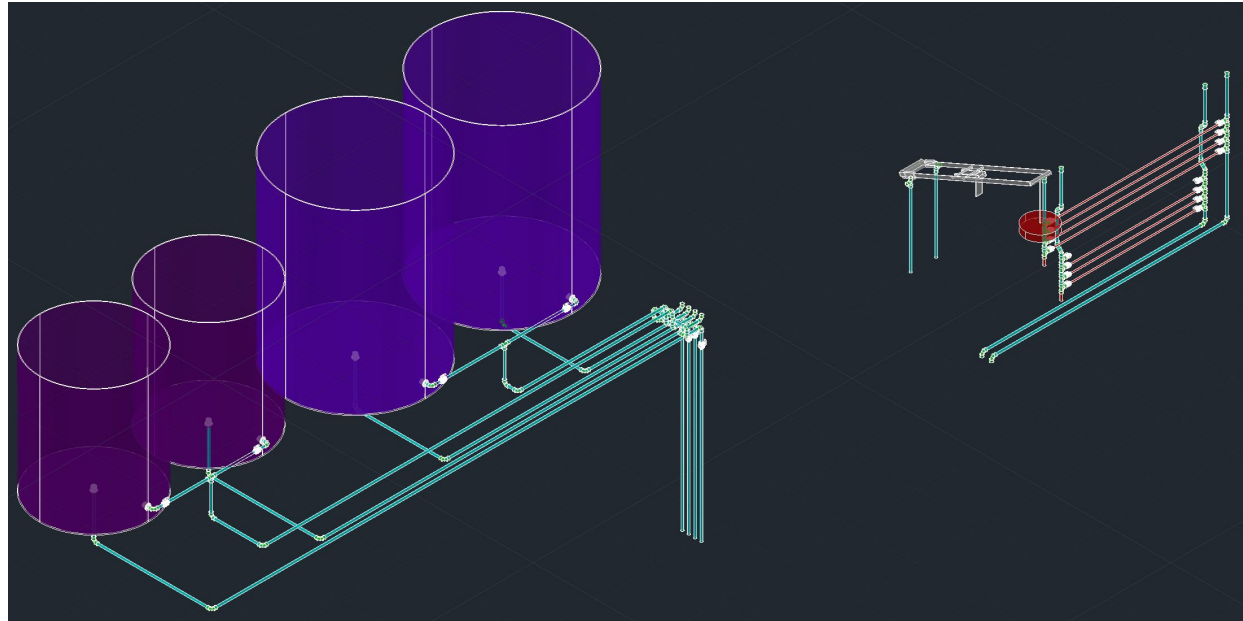
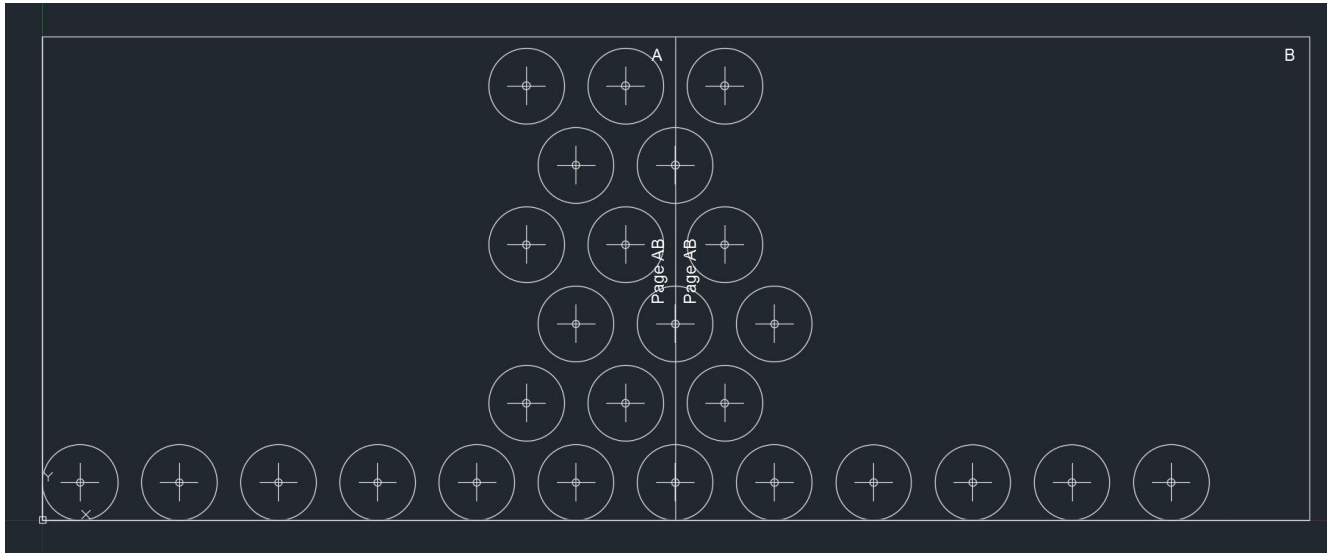

Figure 4: The combined drawing of the Chemical Storage Tanks (left) and the CDC (right).

The LFOM has a separate template code which needed many revisions.



# The page boundaries cut off at irregular places.

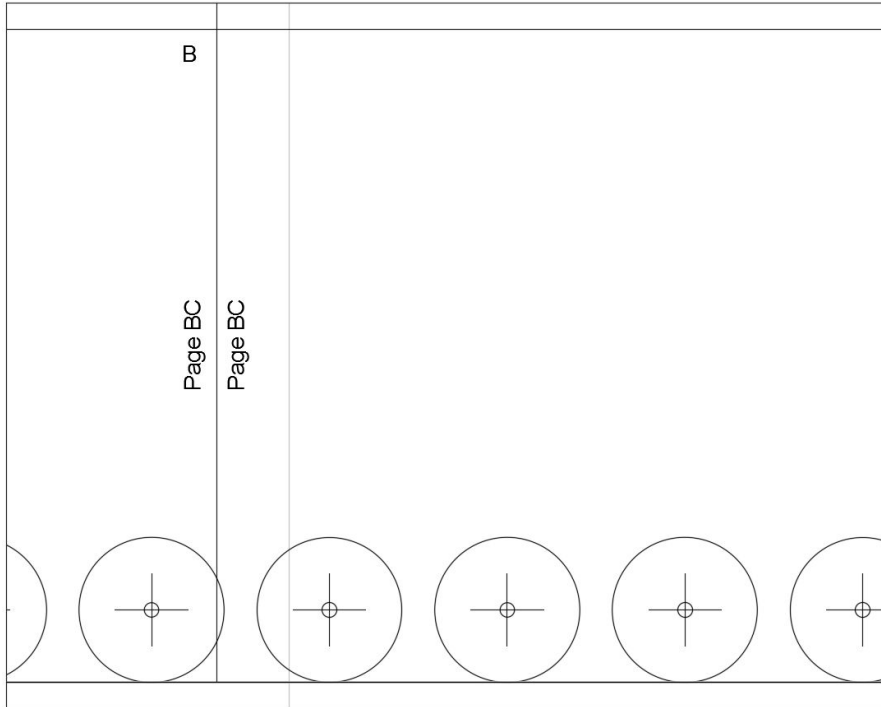

Figure 5: A view of a poorly cut off page.

Figure 6: The last page cut off a single orifice at the end leaving it pageless.

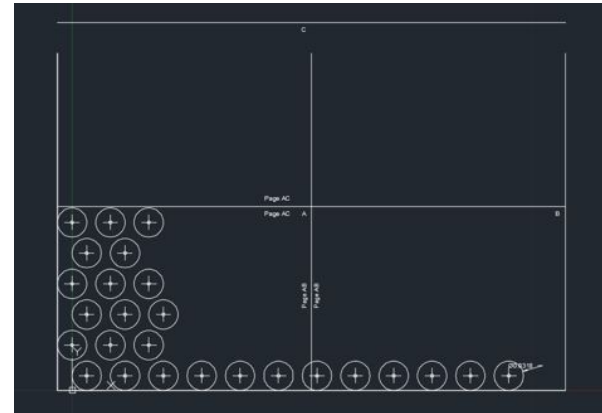
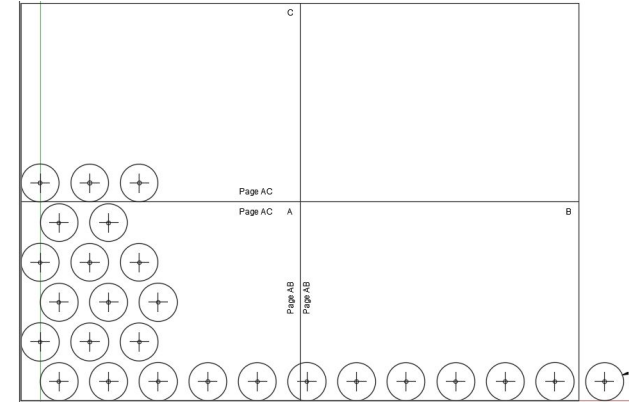

Figure 7: The upper boundary on the top row of pages is disconnected.

# A good looking LFOM has centered orifices.

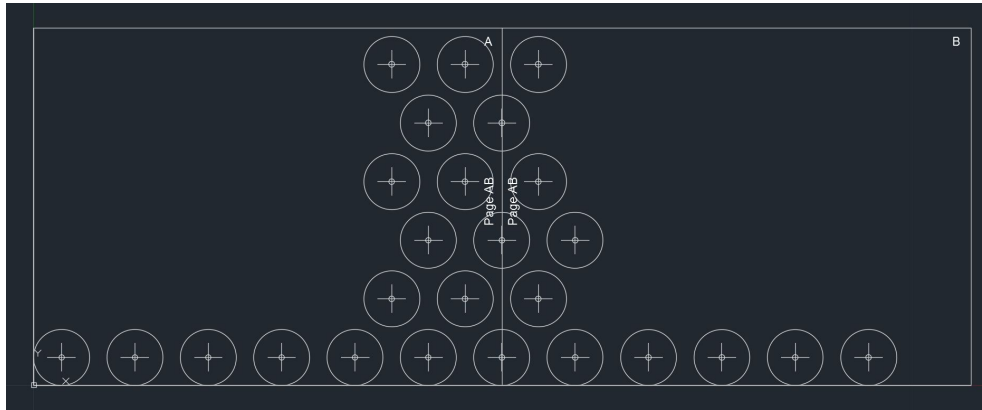

Figure 8: Model view of a properly centered template.

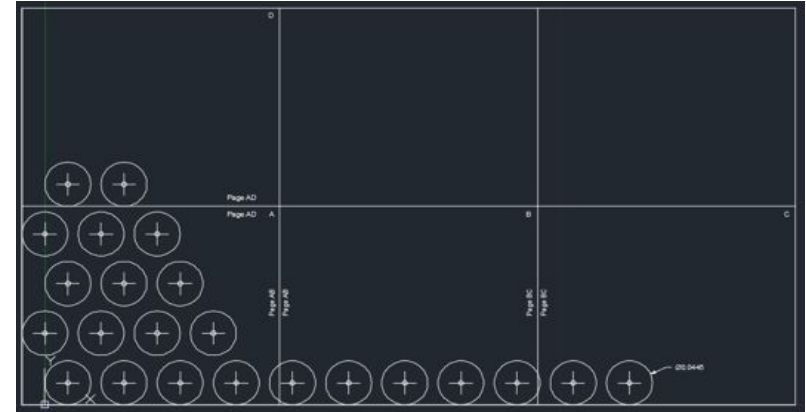

Figure 9: Model view of an improperly centered template.

Shifting the cluster of orifices differed based on the number of orifices.



# The template needed to be scaled to fit the paper space.

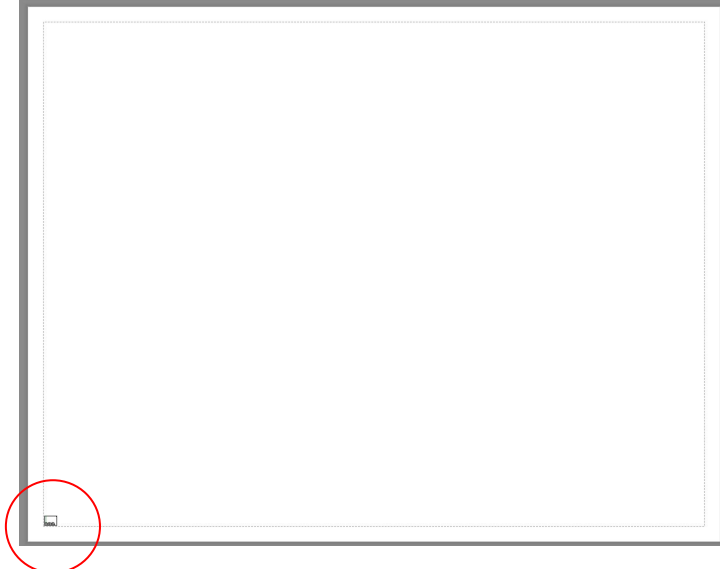

Figure 10: The page of orifices that should have been printed on the page is the tiny rectangle.

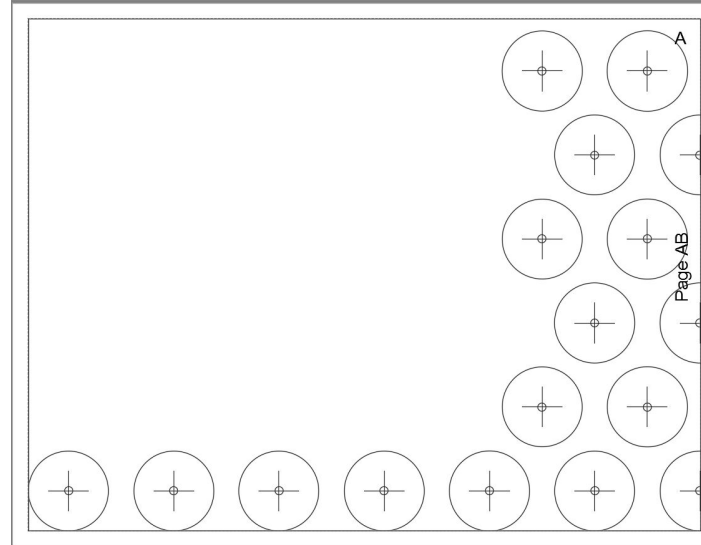
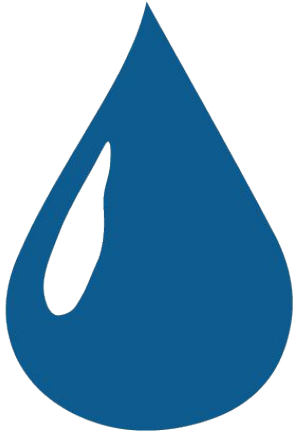

Figure 11: The page fits the whole paper when scaled.

- AutoCAD made the page 11" x 8.5", but 1m=1in. in the page.
- The fix was to scale up the model by a factor of 39.37 (# in. in 1m) when setting up the page.

# Transition Flow Rates

This team is a subset of the Design team whose main focus is to determine flow rate transition zones for AguaClara plants.



# AguaClara has three types of plants: low flow, standard, and high flow.

- Main differences: number and type of filters, number of sedimentation tanks

Description	Constraint that governs upper transition	Min Q L/s	Max Q L/s
pipe flocc, circular PVC pipe sed tank, EStARS	economics		?
2 or more EStARS 1 rectangular sed tank	maximum flow in one sed tank		5.x
2 or more EStARS 2 or more sed tanks	switch to multiple sed tanks	5.x	16
2 or more OStARS	??	16	100?
Multiple treatment trains		100?	1000

Table 1: The original transition zones

Low Flow plants use EStaRs because the OStaRs filter box at low flow rates is too small.

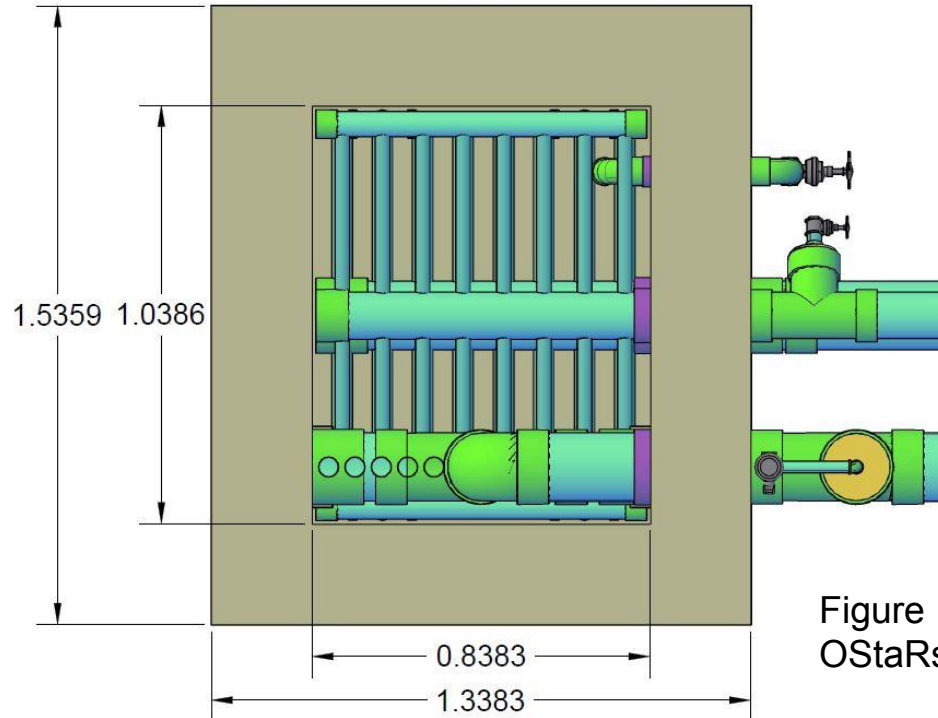

- 16 L/s = two 8 L/s filters
- Constructability
  - Mason's Arm Constraint

Figure 1: The filter box for an 8 L/s OStaRs filter.

Low flow plants could also have multiple sedimentation tanks.

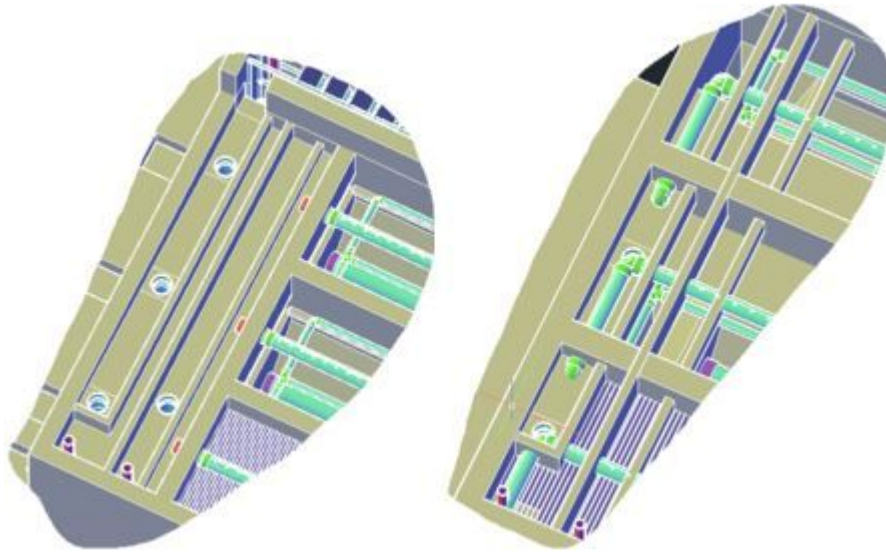

Figure 2: The channel system in a standard plant versus the channel system in a low flow plant.

An inlet/ outlet channel system would need to be added based on construction costs.

## High flow plants are governed by the LFOM.

- No elbow in the LFOM anymore
  - Can now push the LFOM pipe to as big as we want it to be!
  - 24 inches is the largest in the database, which was determined from the equation below

$$2 * \sqrt{\frac{(A_{LfomPipeMin}(Q_{Train}, HL_{Lfom}, \Pi_{LfomSafety}))}{\pi}}$$

Figure 3: LFOM pipe size equation

# High flow plants still have issues.

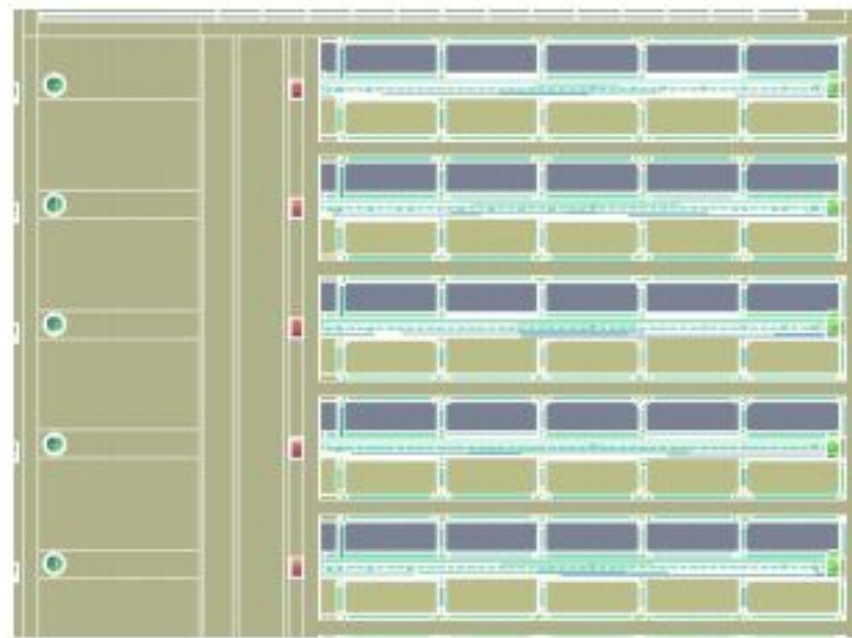

Figure 4: Channel system in a 150 L/s plant

# There is a new chart for the transition flow rates.

**Transition Flow Rates**

Description	Upper Constraint	Min Q L/s	Max Q L/s
Pre-fab plants	Number of pre-fab plants needed, beyond 4.9 L/s, use EStaRS design with sed tanks	1	4.9
2 <u>EStaRS</u> 1 sed tank with room for more sed tanks (include sed inlet and outlet channels when building)	A bigger sed tank (inlet manifold length of 3.5m) could be used at 7.5 L/s	5	<7.5
2 <u>EStaRS</u> or more 2 sed tanks	The masonry needed for the filter box for OStaRS gets too difficult (too small for a normal sized person to maneuver) below 16 L/s.	7.5	16
2 or more <u>OStaRS</u>	Due to a 24in LFOM (biggest pipe size in database)	16<	150
Multiple treatment trains (multiple chemical dosing, entrance tanks, flocculators)		150	1000

Table 2: The new transition flow rates



The code and design server were changed to reflect the new transition zones.



$Q_{TrainMax} := 150.1 \frac{L}{s}$  due to a 24 in LFOM because that's the biggest pipe we have in our database right now. if we need a bigger single train, we can do that by adding that pipe size into the pipe database

$$EN_{DoubleTrain} := \begin{cases} 1 & \text{if } Q_{Plant} \geq Q_{TrainMax} \\ 0 & \text{otherwise} \end{cases}$$

Double Train is not a good name for this variable, because we may have four train plants as we continue to reach higher flow rates. However, the cut off points for multiple train plants are not yet set.

$$N_{Train} := \begin{cases} 1 & \text{if } Q_{Plant} < Q_{TrainMax} \\ \text{Ceil}\left(\frac{Q_{Plant}}{Q_{TrainMax}}, 2\right) & \text{otherwise} \end{cases}$$

$$Q_{Train} := \frac{Q_{Plant}}{N_{Train}}$$

$$Q_{PlantMaxLF} := 16 \frac{L}{s}$$

Figure 5: Design code variables that have been changed

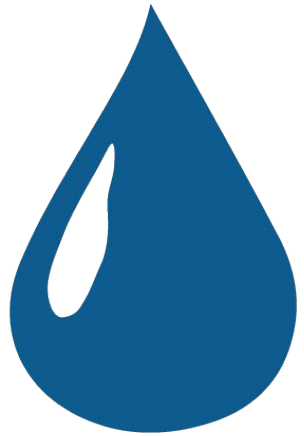

# StaRS Updates

AutoCAD scripts for the OStaRS platform and spacer and AutoCAD drawings for the StaRS fabrication molds were completed to reflect current plant layout.



Only one set of Stars Molds in Honduras yet to be completely documented.



Figure 1: 1.5" Curved Mold



Figure 2: 1" Flat Mold



Figure 3: Molded OStaRS  
Pipe Ends

# Communicated with APP engineers and Shop specialists to draft 1.5" Curved Mold.

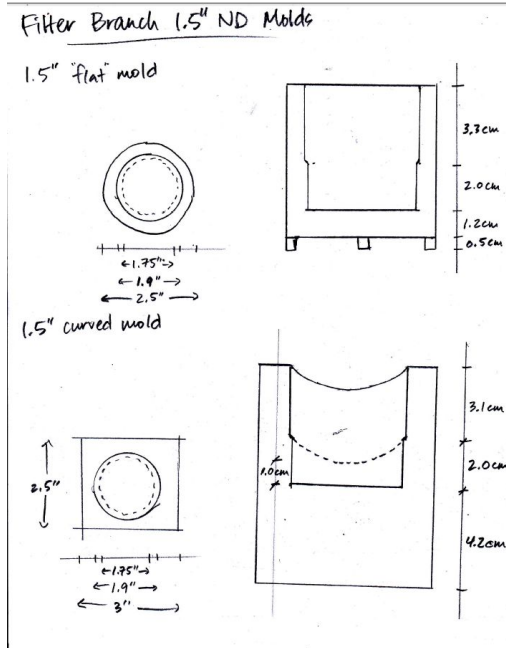

Figure 4: OStaRS Pipe Dimensions

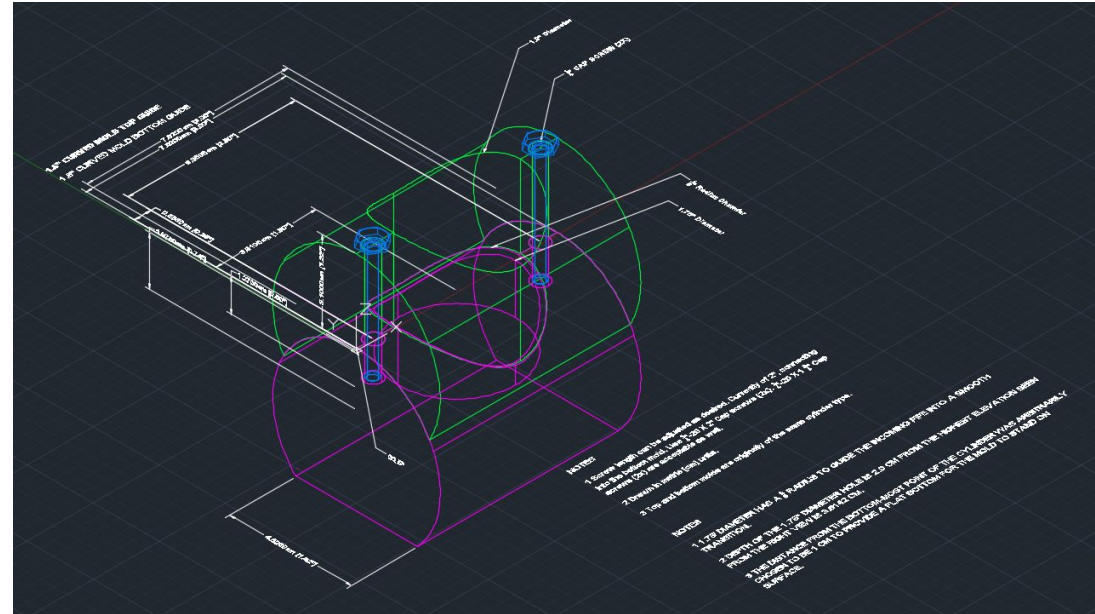
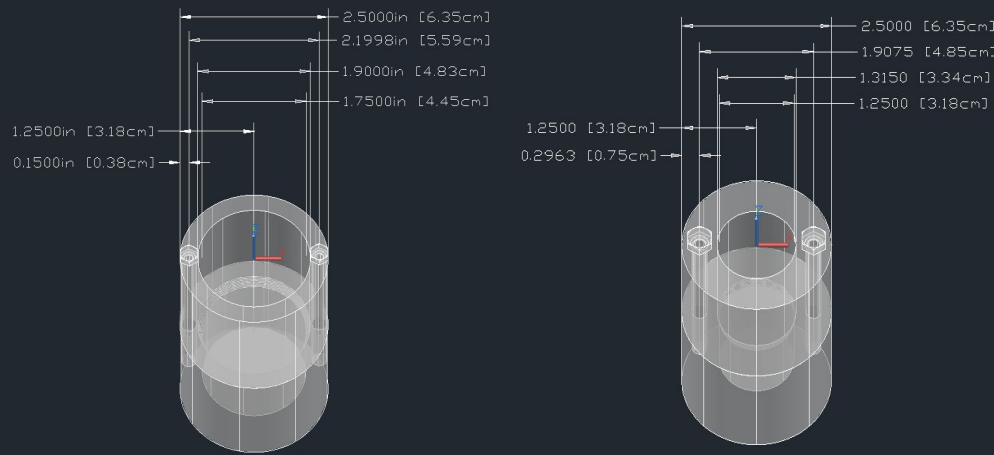

Figure 5: Top and SW /Isometric views of 1.5" Curved Mold.

Figure 6: 1.5" Flat Mold  
Figure 7: 1" Flat Mold



The last three mold types, 1", 1.5", flat and curved were also drawn.

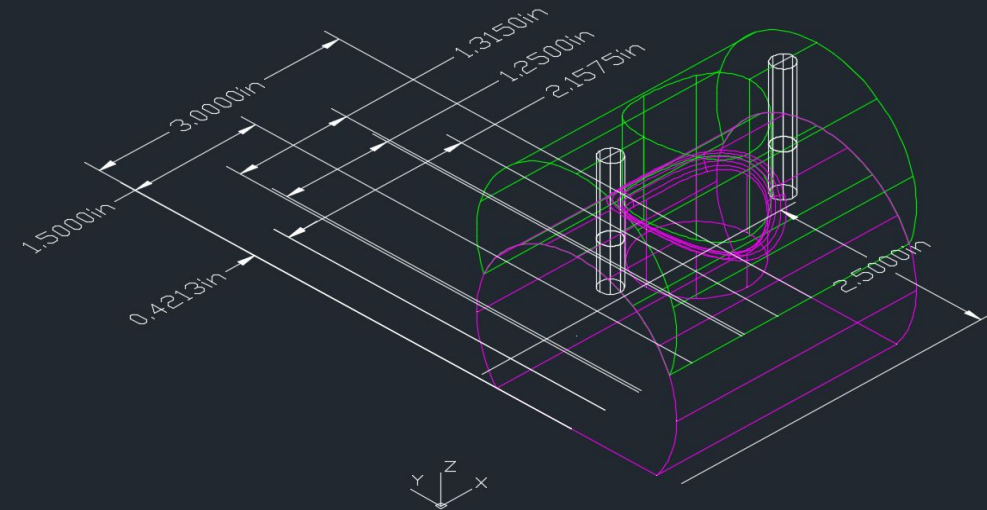

Figure 8: 1" Curved Mold

# Develop AutoCAD script of filter spacer and platform with Fabrication Team.

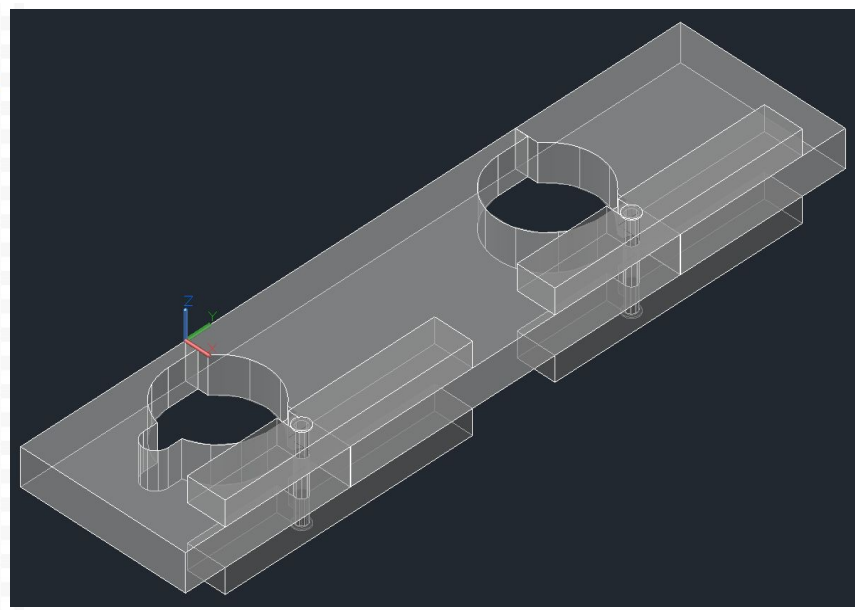
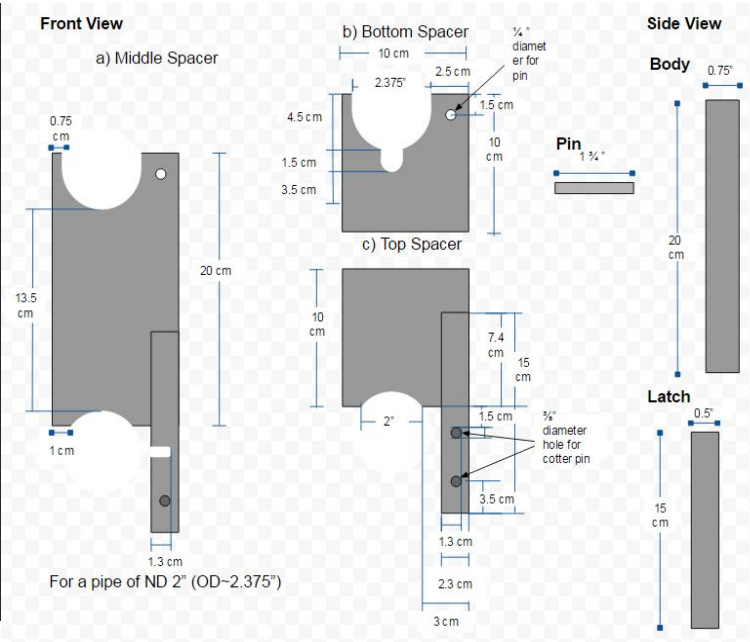
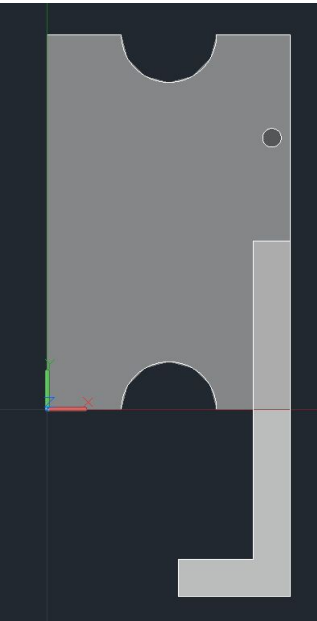

Figure 9: Original AutoCAD script drawing from Fabrication Team.



Figure 10: Spacer Schematic

Figure 11: Current Spacer AutoCAD scripted drawing.

# OStaRS platform design were updated with inserted hinge and screw drawings.

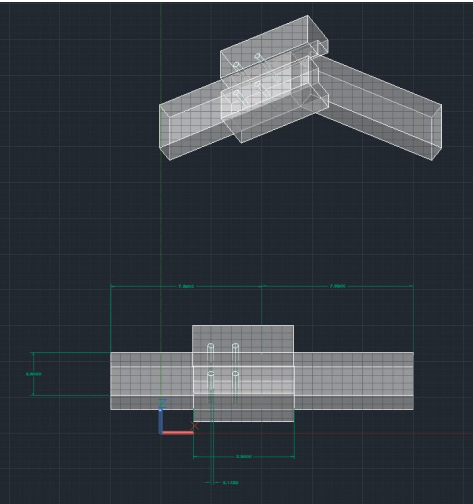

Figure 12: Original Platform AutoCAD Drawing from Fabrication Team.

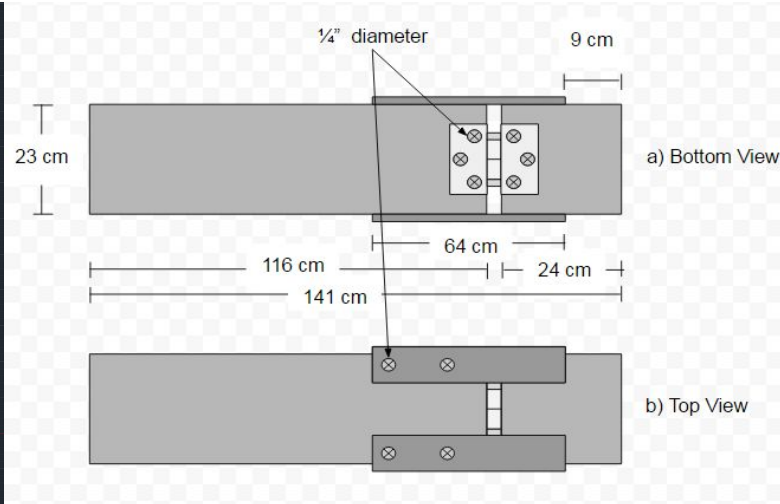

Figure 13: Platform Schematic

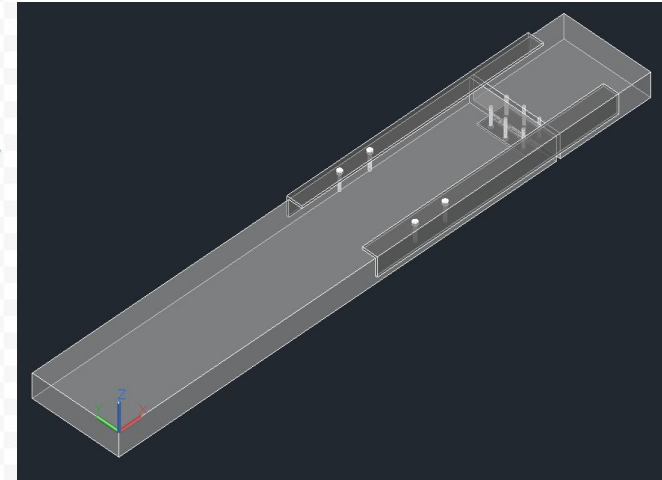
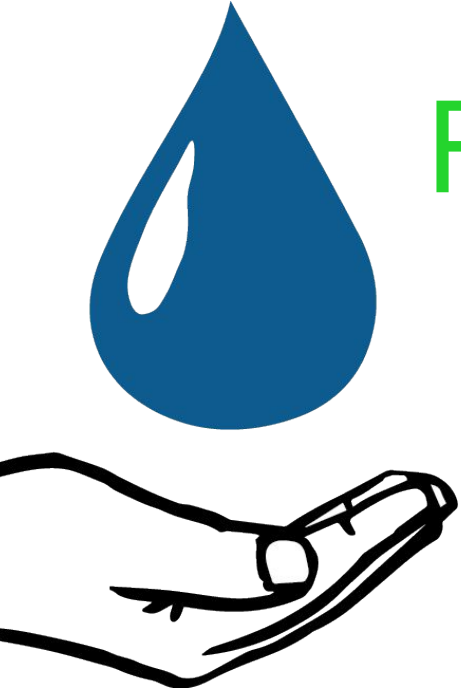

Figure 14: Current Platform AutoCAD scripted drawing.

# Questions and Recommendations



Meghan Furton  
B.S., Environmental  
Engineering  
mrf222@cornell.edu

Paroma Chakravarty  
B.S., Environmental  
Engineering  
pc479@cornell.edu

Sofya Calvin  
B.S., Civil Engineering  
sec293@cornell.edu

Kevin Juan  
B.S., Chemical Engineering  
kj89@cornell.edu

Cinthia Hai Young Kim  
B.S., Civil Engineering  
hk625@cornell.edu



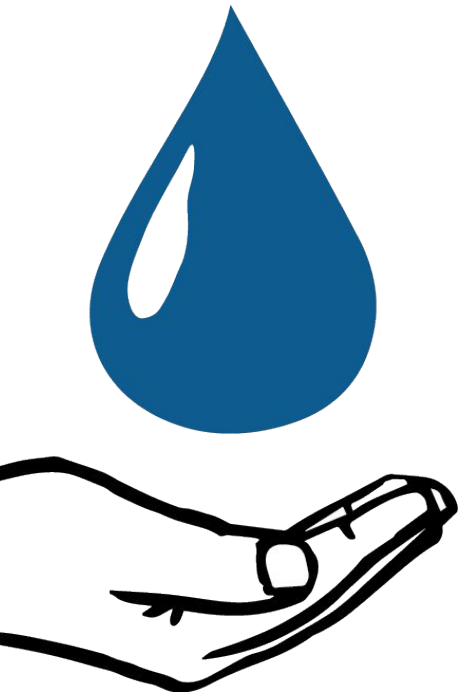

# Appendix Slides

Elbow bridges with 45 degree elbows had drawing errors.

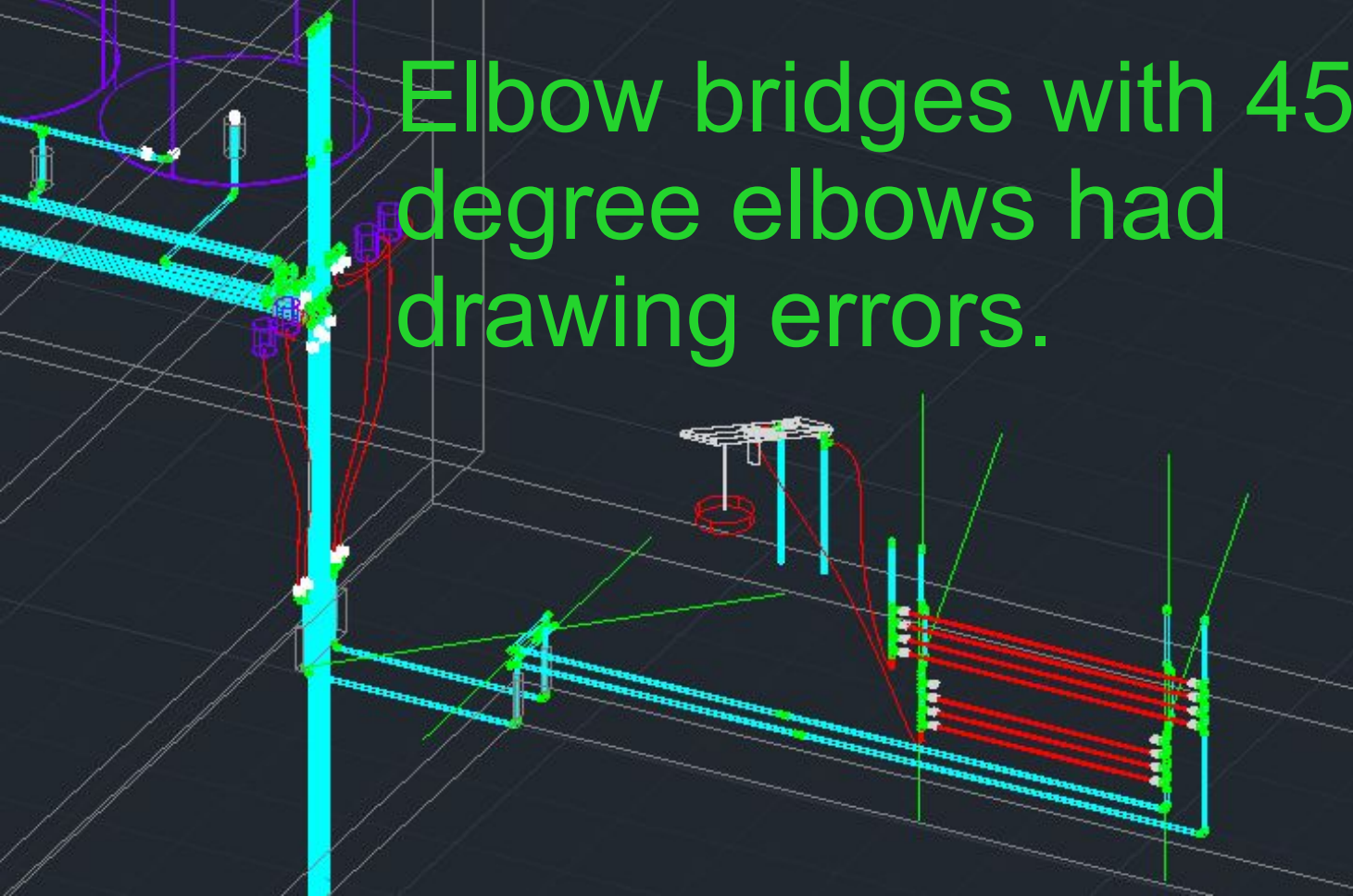

Figure X: Error caused by 45 degree elbow bridges in AutoCAD 2013.

# Sections cuts still need a lot of work.

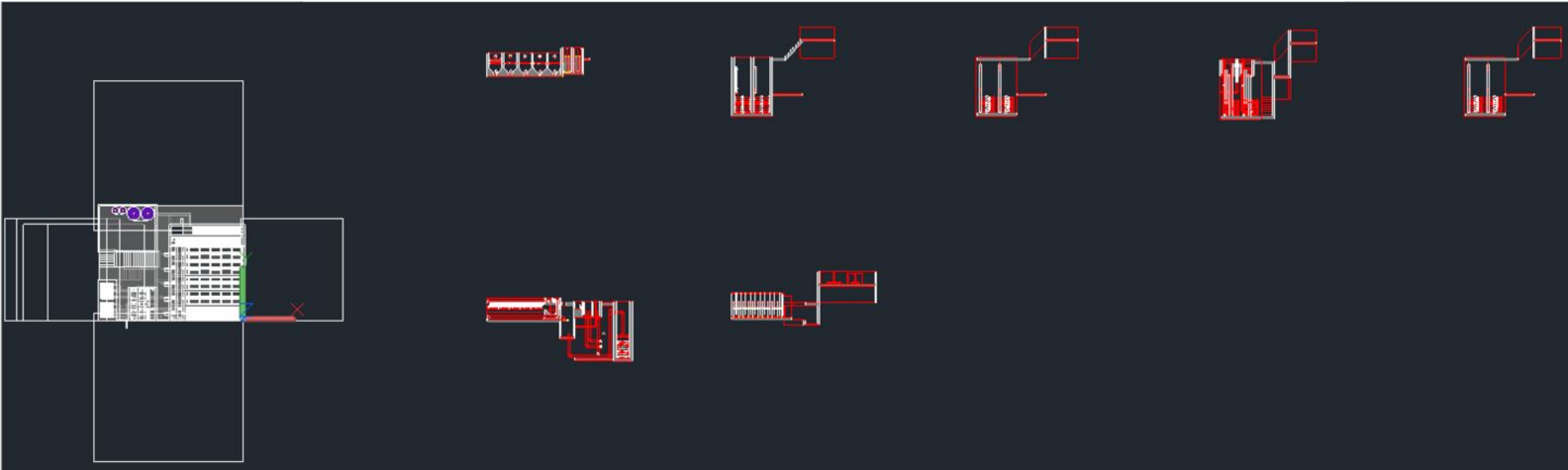

Figure X: Current section cut layout.