



# Plastic Welding

## Part 6: Construction design



**We know how.**

# Part 6: Construction design

---

**The Design of welded structures depends on the physical characteristics of the materials used.**

**Of particular note are the types of stress.**

# Part 6: Construction design

## Force deflection & notch effect

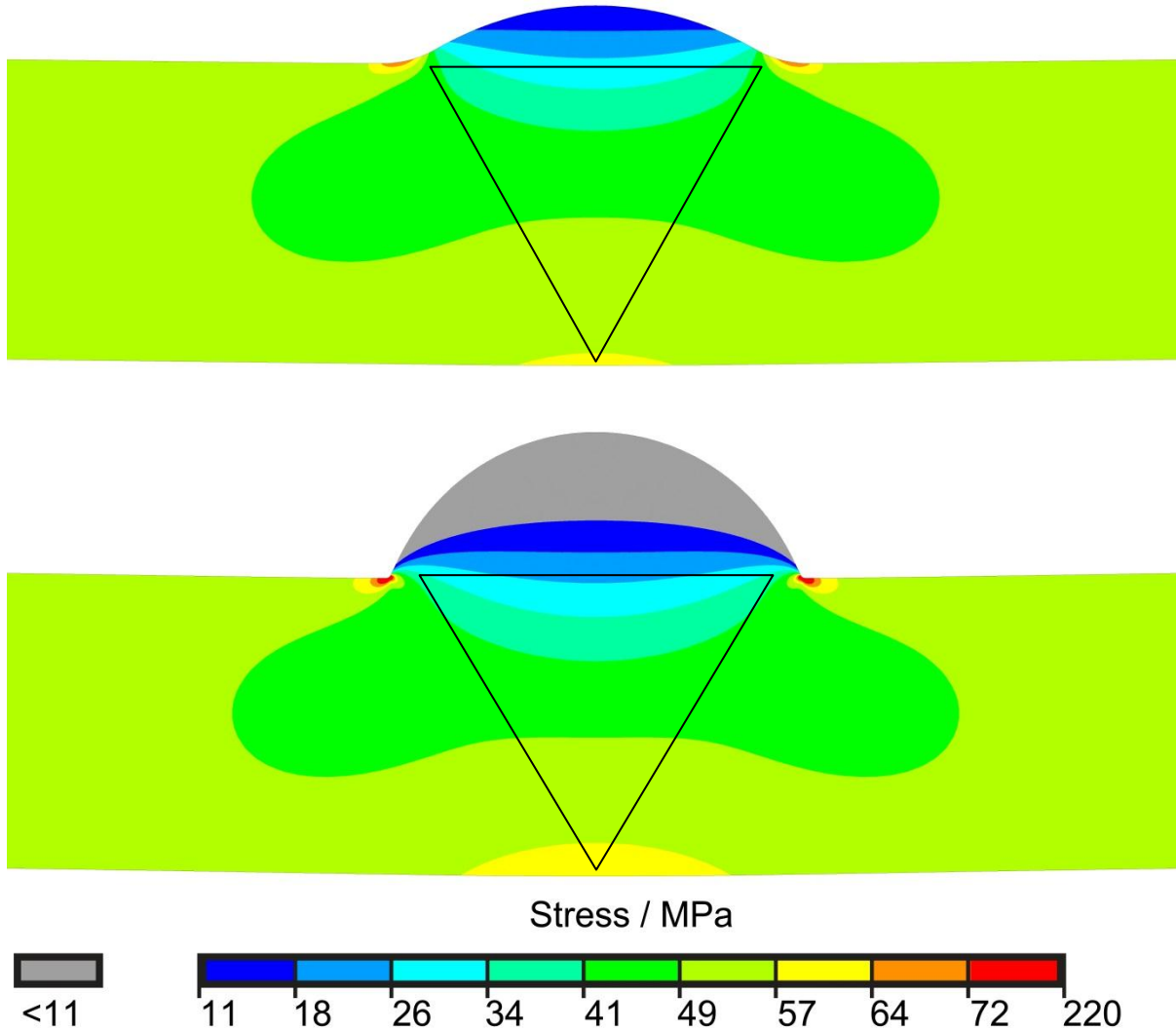

# Part 6: Construction design

## Force deflection

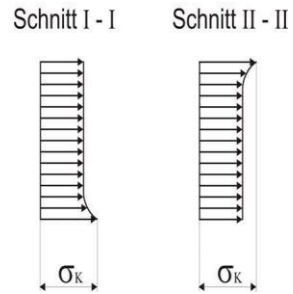
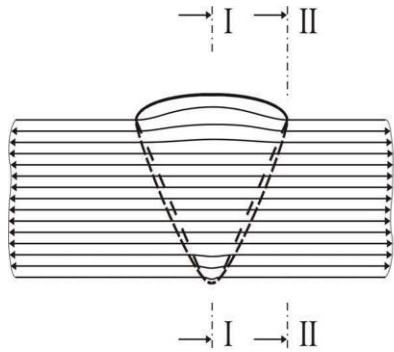

unfavourable

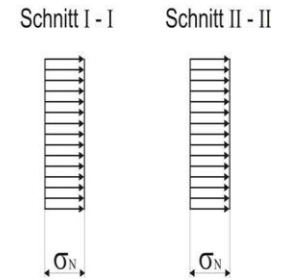
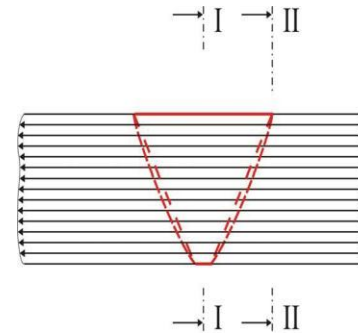

favourable

# Part 6: Construction design

## Force deflection

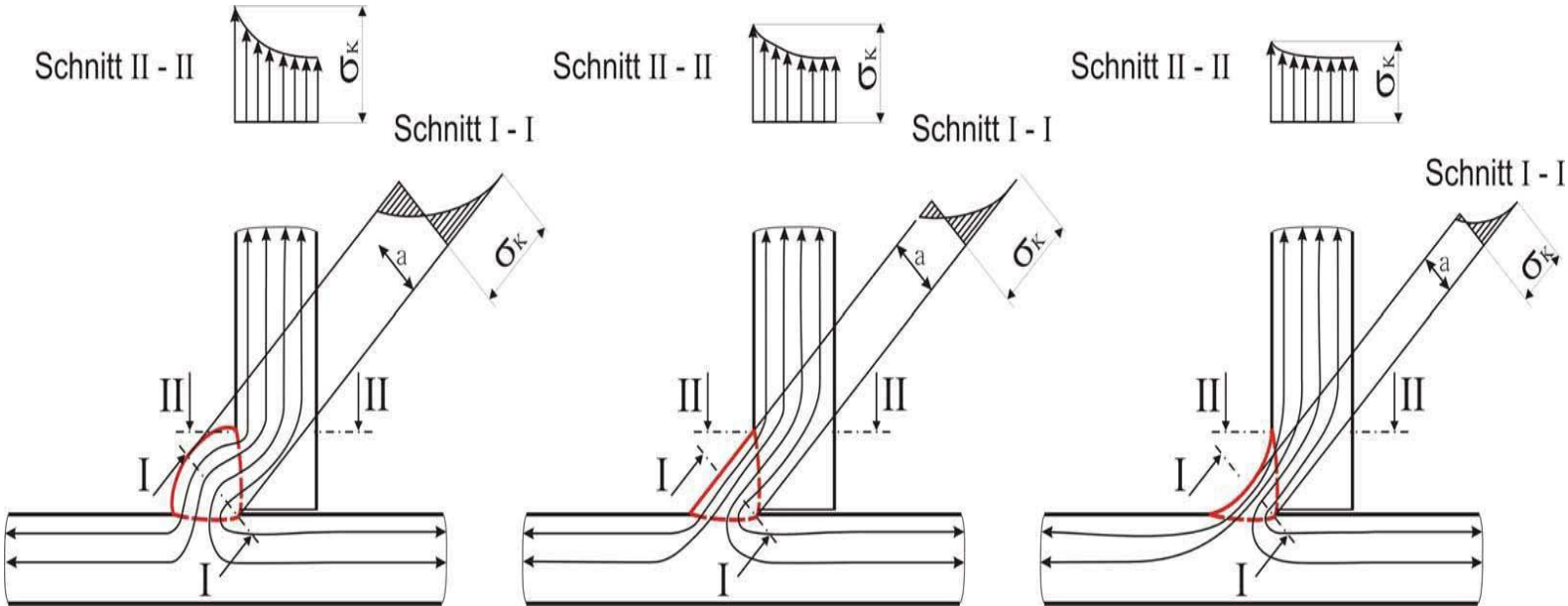

# Part 6: Construction design

## Force deflection

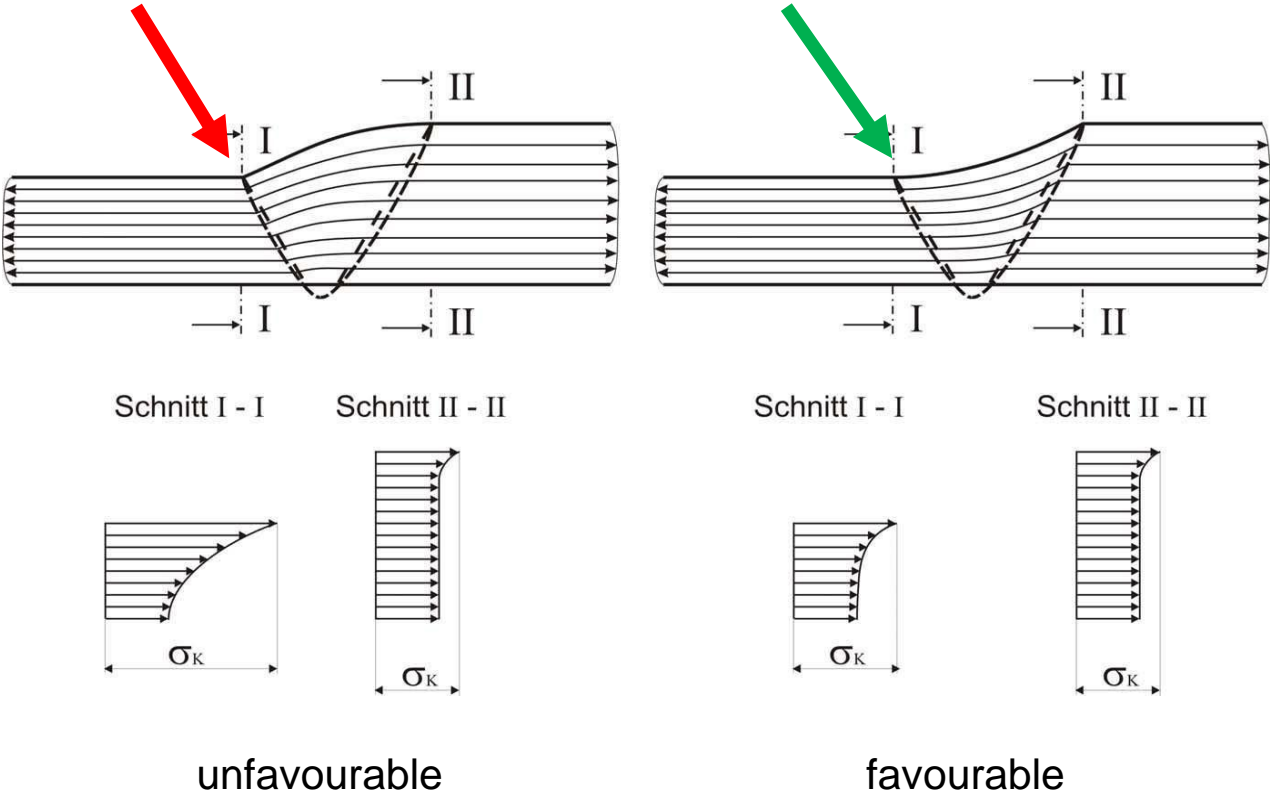

# Part 6: Construction design

## Design recommendation

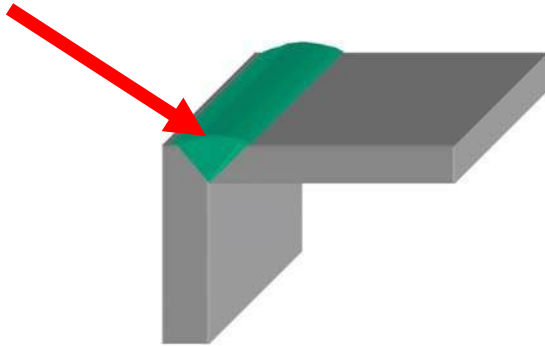

unfavourable

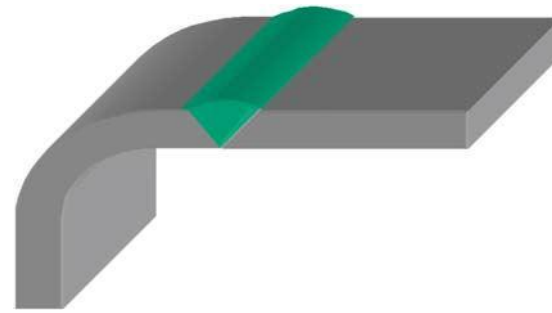

favourable

Put welding connections to the outside of the main exposure zone.

# Part 6: Construction design

## Design recommendation

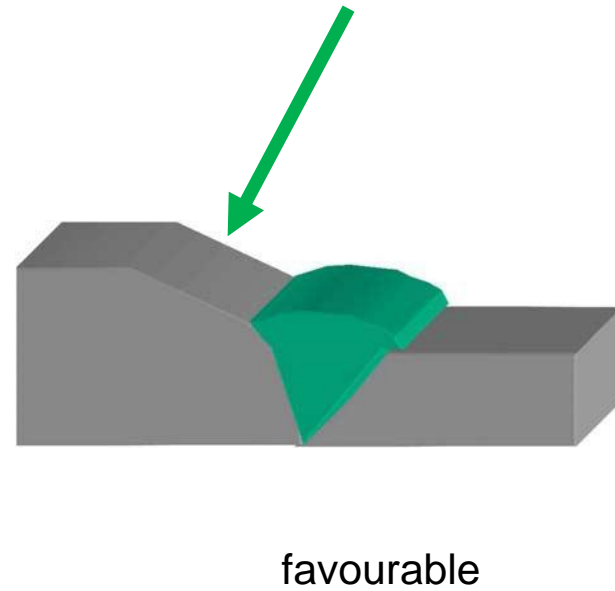
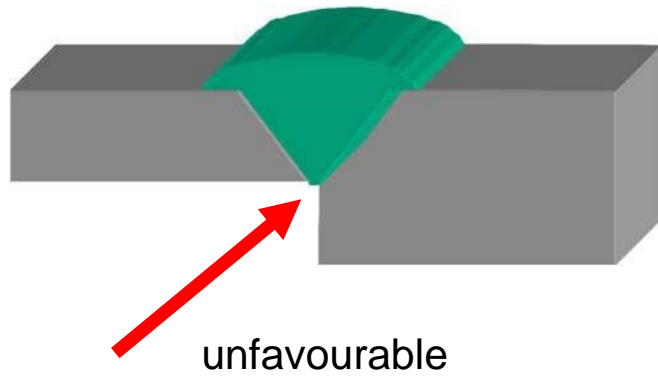



# Part 6: Construction design

## Design recommendation

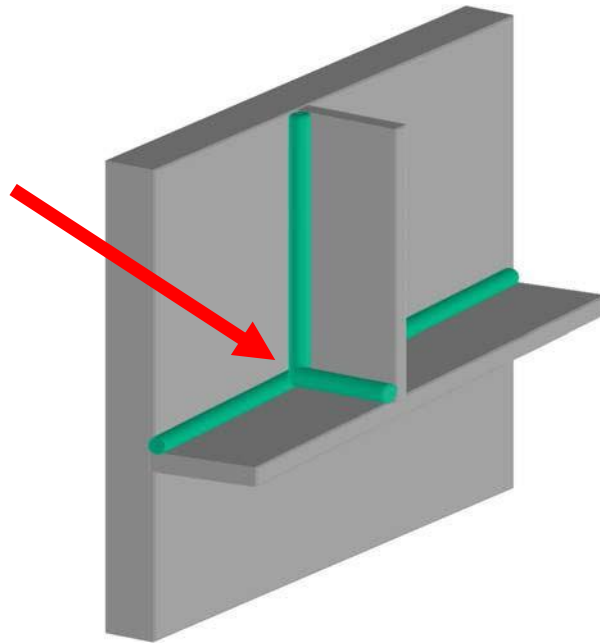

unfavourable

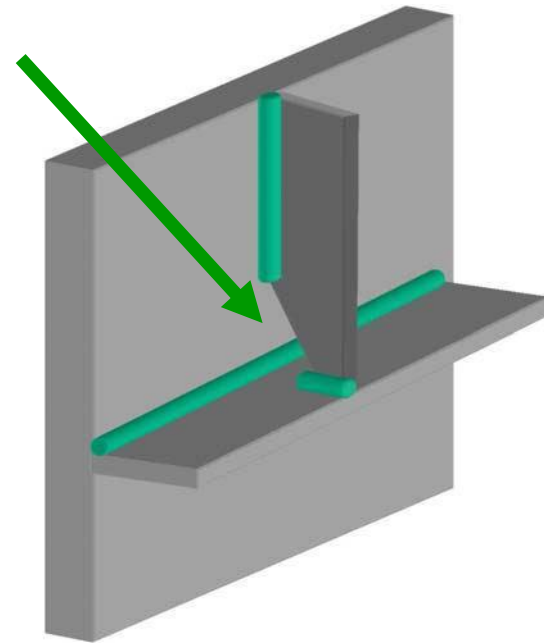

favourable

# Part 6: Construction design

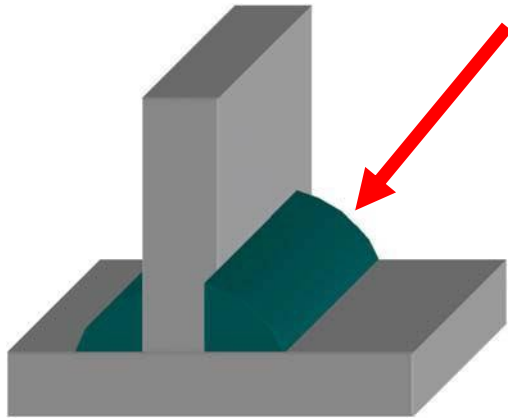

unfavourable

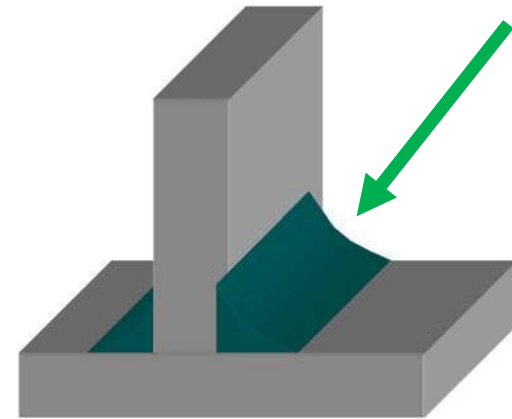

favourable

# Part 6: Construction design



unfavourable

favourable