

# Spacecraft Mechanical Engineering

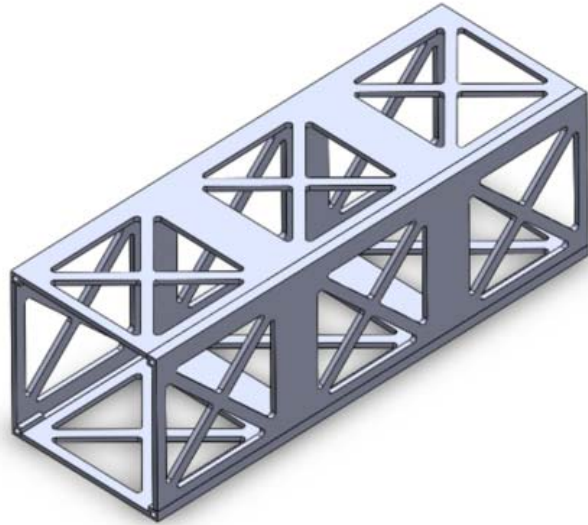
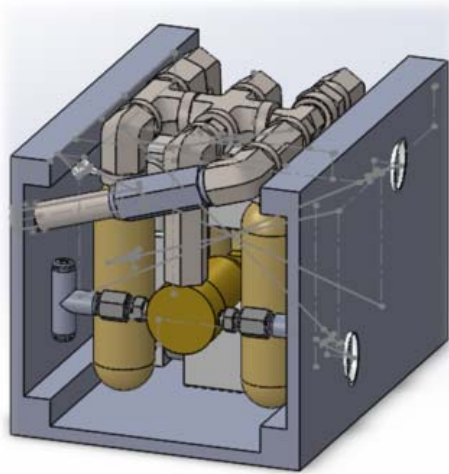

Advisor: Mason Peck, [mp336@cornell.edu](mailto:mp336@cornell.edu)

Number of students: 1-2

Majors: Upper-level undergraduate or MEng; MAE or AEP

The student will work with a small team of Ph.D. students and undergraduates on a NASA-sponsored project called “On-Orbit Autonomous Assembly with Nanosatellites.” The goal of the research is to design and build a prototype pair of small spacecraft capable of autonomously docking in orbit to demonstrate a robust technique for robotic assembly of much larger space systems. The two spacecraft for this flight experiment are 3U CubeSats.

The mechanical-engineering role focuses on design and analysis of spacecraft structures and mechanisms, as well as thermal modeling. The student must be proficient in Solidworks and have completed introductory undergraduate coursework in thermal analysis in a mechanical context.

Some familiarity with spacecraft technologies and design practices is required—whether through previous coursework or (preferably) experience with CubeSat design and fabrication. The student will work with NASA engineers and on flight systems; so, an ability to conduct applied research on high-value hardware and communicate with diverse team members in a rigorous professional environment is necessary.