

Graphical User Interface for circuit analysis: towards an auto-grader

The goal of this project is to create a graphical user interface that will allow students to record the process by which they analyze analog circuits (label currents/voltages, write equations, etc). This interface will be the basis of creating an auto-grader that will be able to provide personalized feedback for students learning about analog circuits.

Similar tool for learning how to construct automata can be found here:

<http://www.automatatutor.com/>

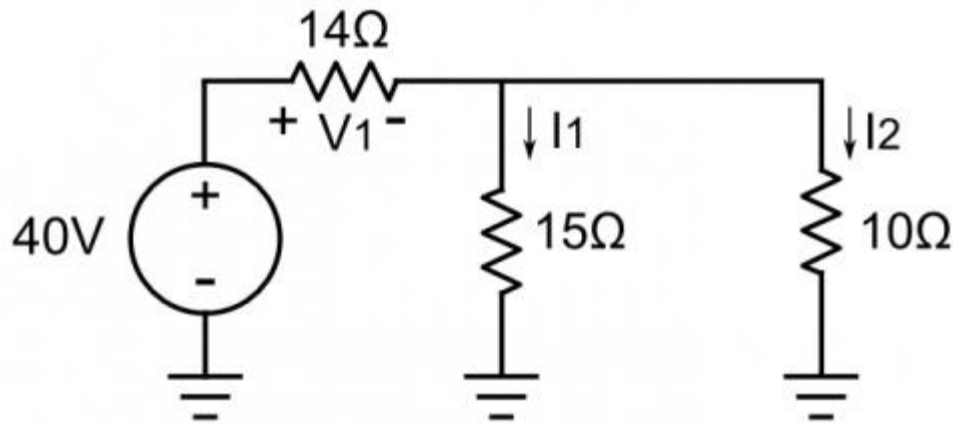

<http://www.eeweb.com/electronics-quiz/basic-circuit-analysis-find-the-current-and-voltage>

The project milestones are:

- Create a conceptual design for such an interface that would be appropriate for passive circuits, circuits with active elements and circuits with diodes. This design must capture all the steps of analyzing the circuit
- Implement the design so that it can run in a browser
- Set up a server to collect the information

Requirements: MAE 3780 or ECE 2100

Course number: MAE4900/MAE6900

Credits: 4

Contact: Prof. Hadas Kress-Gazit (hadaskg@cornell.edu), Prof. Erik Andersen (eland@cs.cornell.edu)