

# Design Team–Chemical Dose Controller Design, Spring 2015

Michelle Lee

May 13th, 2015

## Table of Contents

[Table of Contents](#)

[Part I: Problem Definition](#)

[Introduction](#)

[Design Details](#)

[Part II: Documentation](#)

[Achievements](#)

[Challenges](#)

[Future Goals](#)

## Part I: Problem Definition

### Introduction

As AguaClara continued to improve the design of the Chemical Dose Controller(CDC) in their water treatment plants, the CDC design team worked to modify the current CDC drawing script to reflect the most up-to-date CDC system built in AguaClara plants. Over the past semesters, continuous efforts were made to improve the design code for the CDC. This semester, the goal of CDC design task was to continue to incorporate changes into the existing CDC design code and to complete the CDC drawing. There were three main tasks in CDC design code modification. First, the CDC design code had to be updated to include Chemical Storage Tank Platform walls and to relocate and re-scale the platform's

staircase. Second, adjustments to the position and scale of the Constant Head Tanks(CHT) had to be made. Finally, the lever arm design needed to be finalized.

## Design Details

In the past, the CDC design code was incomplete and did not include many features that the actual CDC system had. In order to complete the drawing of the CDC so that it reflected the most up-to-date features of the Chemical Dose Controller, the updates mentioned above were made. The CDC design code from last semester did not draw out the chemical storage tank platform walls. Therefore, the code was updated this semester to draw out the platform walls. To achieve this goal,, the dimension of the Chemical Storage Tank Platform had to be calculated because incorporating the platform walls left less space for the platform itself. The drawing functions for the platform walls were also redefined. The dimension and position of the staircase were also corrected to reflect its actual design in the plants. In addition, the CHT should be drawn on the chemical storage tanks platform walls. This semester, the origins of the CHT in CDC design code were modified such that the CHT would be drawn on the platform wall. In addition, the lever arm had an incorrect orientation and efforts were put in to redetermine its origin and rotation angle such that it matches with the orientation it has in an actual plant.

## Part II: Documentation

### Achievement

3/6/2015

After evaluating the CAD drawing of the stairs at the Chemical Storage Tank Platform, it was decided that it did not correctly represent how it should look like in an actual plant. The code needed for drawing the platform stairs was redefined, such that the code would draw the stairs of moderate width. Design code for walls around the platform was also added to the existing code.

It had been tested and it gave a good illustration of actual plant's platform. Figure 1 shows the modified CDC platform.

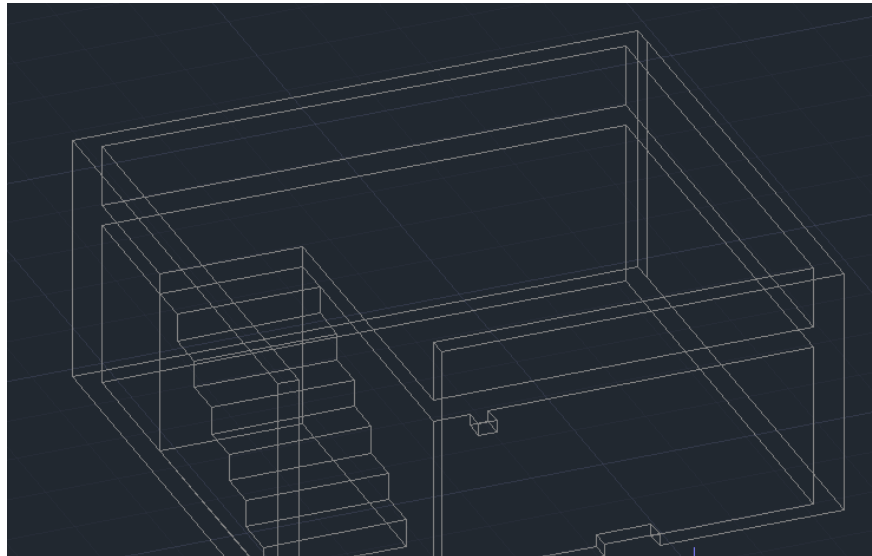

Figure 1: Modified CDC platform with walls

3/20/2015

With the implementation of the platform walls drawing, the Constant Head Tanks, columns and the CHT mounting board would overlap with the platform walls drawing. The design code for the CHT system was corrected such that the CHT system would not be drawn on top of the walls. Figure 2 shows the original view of the CDC platform with incorrect positioning of the CHT. Figure 3 shows the drawing of Constant Head Tanks system with modified origin.

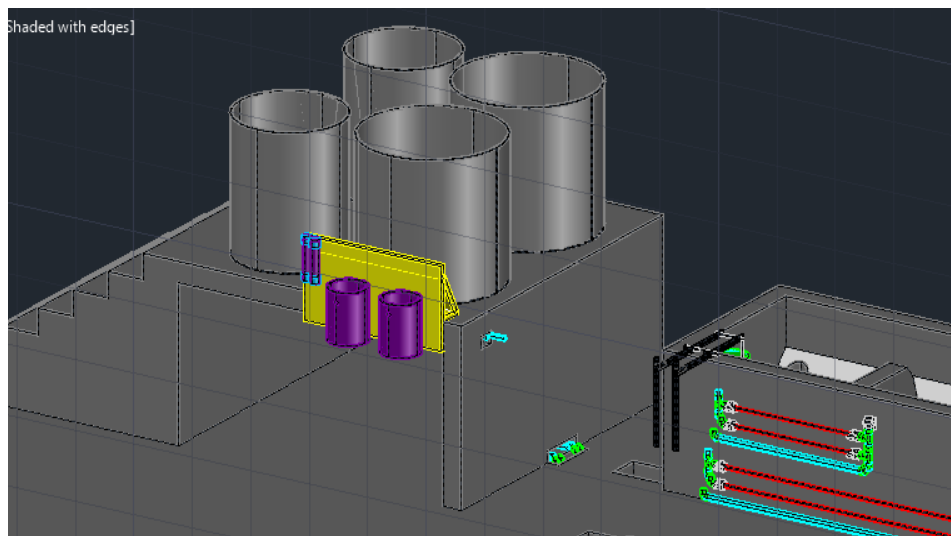

Figure 2: Original view of the CHT and Chemical Storage Tanks platform

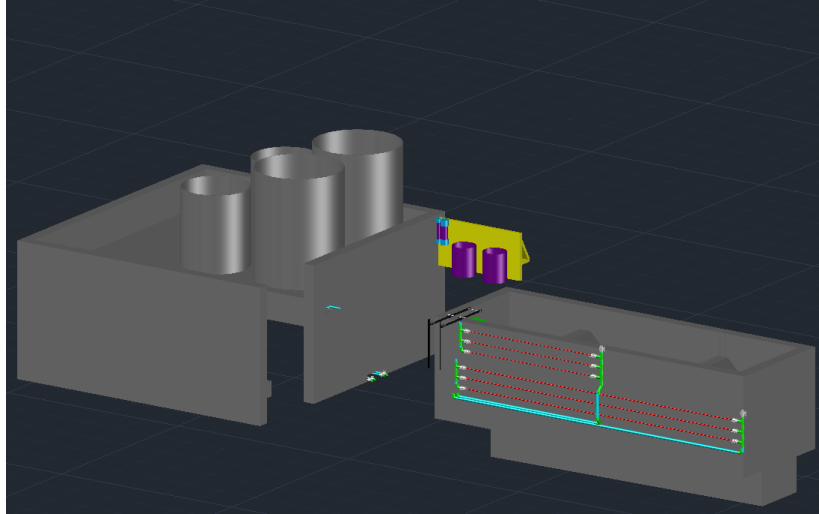

Figure 3: View of the CDC with repositioned CHT and calibration columns

3/27/2015

In the previous CDC design code, the Chemical Dose Controller Platform exceeded the water treatment plant boundary. The error was corrected by reducing the x- and y- dimension of the platform by the thickness of the platform walls. The origin of the Constant Head Tank system was also changed to avoid exceeding the plant boundary. Please see Figure 4 and 5 for side and top views of the CDC system with above modification. Platform walls drawn right next to the staircase were removed as there were no walls built next to the staircase in the actual AguaClara plant. Please see Figure 6.

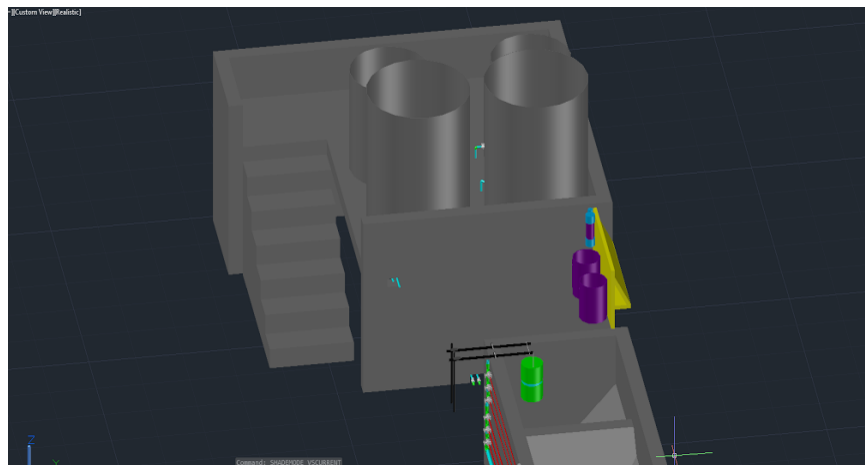

Figure 4: side view of the modified CDC platform and CHT

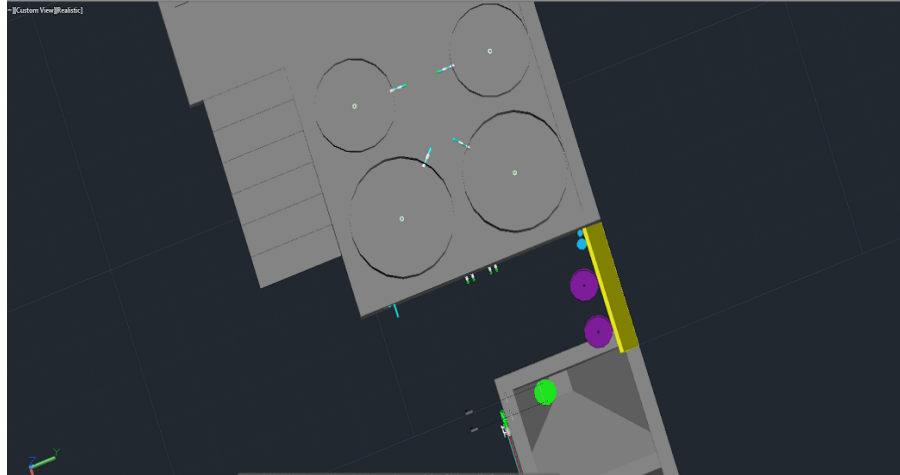

Figure 5: top view of the modified CDC platform and CHT

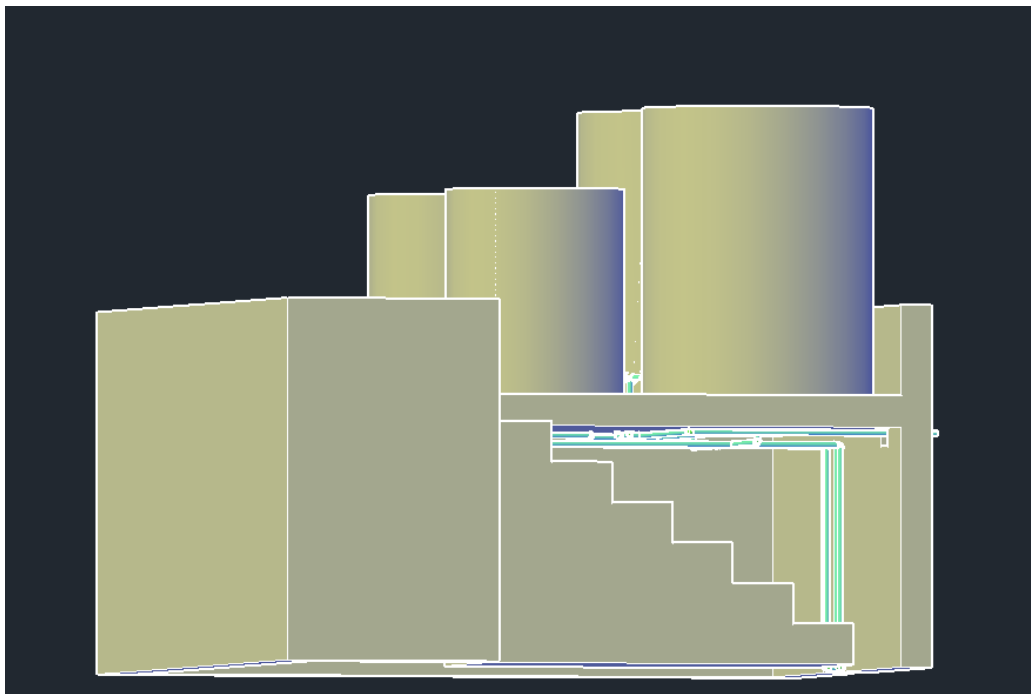

Figure 6: Staircase without walls drawn right next to it

4/9/2015

The origins of the Chemical Storage Tanks were recalculated and the CDC system was corrected such that there was enough space between the Chemical Storage Tanks and the platform walls. One half of the plant walls' thickness was subtracted from the y-coordinate of the Chemical Storage Tanks' origin. The code that drew the platform wall holes, which allow pipes to go through, was also adjusted to accommodate the changes to the CDC platform. Half of the platform wall thickness was also subtracted

from the y-coordinate of holes' origin. Figure 7 shows the changes to the drawing with above update and Figure 8 shows the code modification.

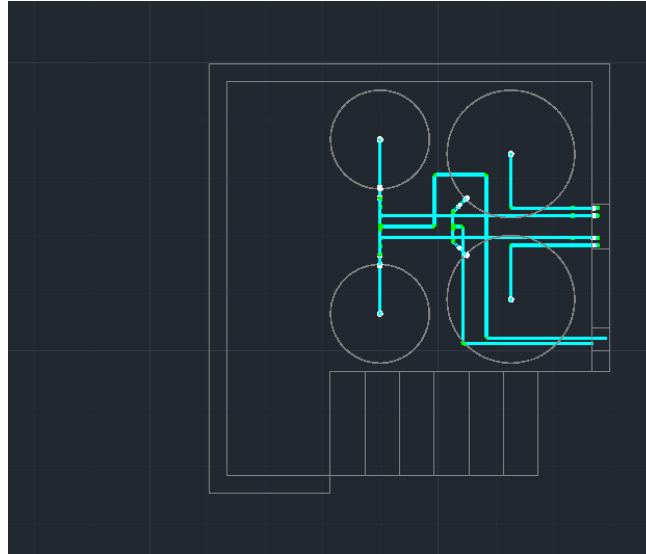

Figure 7: Top view of the modified CDC platform

$$\begin{aligned}
 \text{CoagTankOrigin} &:= \left[ \begin{array}{l} \text{EtOrigin}_0 - L_{\text{Et}} - 2T_{\text{PlantWall}} - S_{\text{ChemTankBorder}} - R_{\text{CoagTank}} - T_{\text{ChemTankWall}} - L_{\text{ChemTankShift}} - (T_{\text{ChannelWall}} + T_{\text{ConcreteMfn}}) \\ \text{EtOrigin}_1 - \frac{3}{2}T_{\text{PlantWall}} + W_{\text{EtChemPlatform}} - R_{\text{CoagTank}} - S_{\text{ChemTankBorder}} \\ Z_{\text{CoagulantTankBottom}} \end{array} \right] \\
 &\left( \begin{array}{l} \text{EtOrigin}_0 - L_{\text{Et}} - T_{\text{PlantWall}} - S_{\text{ChemTankBorder}} - R_{\text{CoagTank}} - T_{\text{ChemTankWall}} - L_{\text{ChemTankShift}} \\ \text{EtOrigin}_1 + W_{\text{Et}} + \frac{1}{2}T_{\text{PlantWall}} - S_{\text{ChemTankBorder}} - R_{\text{CoagTank}} - T_{\text{ChemTankWall}} \\ Z_{\text{CoagulantTankBottom}} \end{array} \right) \text{ otherwise} \\
 \\
 \text{ChlorineTankOrigin} &:= \left( \begin{array}{l} \text{CoagTankOrigin}_0 - R_{\text{CoagTank}} - S_{\text{ChemTankBorder}} - R_{\text{ChlorineTank}} - 2T_{\text{ChemTankWall}} \\ \text{EtOrigin}_1 + W_{\text{Et}} + \frac{1}{2}T_{\text{PlantWall}} - T_{\text{ChemTankWall}} - R_{\text{ChlorineTank}} - S_{\text{ChemTankBorder}} \\ \text{CoagTankOrigin}_2 \end{array} \right) \text{ if ENDoubleTrain} = 0 \\
 &\left( \begin{array}{l} \text{CoagTankOrigin}_0 - R_{\text{CoagTank}} - 2T_{\text{ChemTankWall}} - R_{\text{ChlorineTank}} - S_{\text{ChemTankBorder}} \\ \text{EtOrigin}_1 - \frac{3}{2}T_{\text{PlantWall}} + W_{\text{EtChemPlatform}} - R_{\text{ChlorineTank}} - S_{\text{ChemTankBorder}} \\ \text{CoagTankOrigin}_2 \end{array} \right) \text{ otherwise}
 \end{aligned}$$

Figure 8: Modification to the origin of the Chemical Storage Tanks

4/15/2015

The origins of the Constant Head Tanks and Calibration Columns were redefined. The Constant Head Tanks and the calibration columns had to be placed on the wall of the Chemical Storage Tanks platform, instead of on a mounting board placed in between the platform and the entrance tanks. Design code of the mounting board was removed. The x-coordinate of the Constant Head Tanks and Calibration Columns were redefined such that they each lied on the platform walls. Their y-coordinates were also redefined such that they would be placed next to each other with moderate space in between them. Figure 9 shows the modified code used to change the x- and y-coordinate of the Constant Head

Tanks and calibration as described above. Figure 10 shows the view of CHT and calibration columns after the code was changed.

$$\text{CoagCalColOrigin} := \begin{pmatrix} \text{ChemPlatformOrigin}_0 + \text{ChemPlatformDimensions}_0 + \text{TPlantWall} + \text{ConRadius}(\text{ND}_{\text{CoagCalCol}}) \\ \text{CHT2Origin}_1 - 2 \text{ConRadius}(\text{ND}_{\text{CoagCalCol}}) - \frac{1}{2} D_{\text{CHT}} - 2z_c \\ Z_{\text{CoagulantOutlet}} \end{pmatrix}$$

$$\text{CoagTopCapOrigin} := \begin{pmatrix} \text{CoagCalColOrigin}_0 \\ \text{CoagCalColOrigin}_1 \\ \text{CoagCalColOrigin}_2 + H_{\text{CalCol}} \end{pmatrix}$$

$$\text{ChlorCalColOrigin} := \begin{pmatrix} \text{CoagCalColOrigin}_0 - \text{ConRadius}(\text{ND}_{\text{CoagCalCol}}) + \text{ConRadius}(\text{ND}_{\text{ChlorCalCol}}) \\ \text{CoagCalColOrigin}_1 - 2z_c - 2 \text{ConRadius}(\text{ND}_{\text{CoagCalCol}}) - \text{ConRadius}(\text{ND}_{\text{ChlorCalCol}}) \\ Z_{\text{CoagulantOutlet}} \end{pmatrix}$$

$$\text{ChlorTopCapOrigin} := \begin{pmatrix} \text{ChlorCalColOrigin}_0 \\ \text{ChlorCalColOrigin}_1 \\ \text{ChlorCalColOrigin}_2 + H_{\text{CalCol}} \end{pmatrix}$$

Figure 9: Modification to the origin of the calibration columns

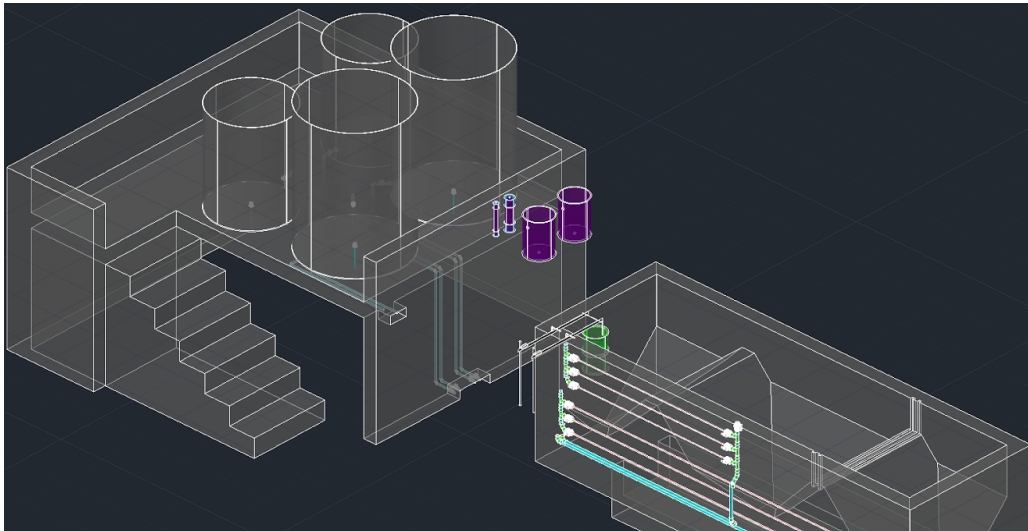

Figure 10: View of modified calibration columns and CHT

4/20/2015

The z-coordinate of the Constant Head Tanks' origin was redefined. The variable originally depended on  $Z_{\text{CdcFloatValveOrifice}}$  in the Entrance Tank file, which was the sum of  $Z_{\text{EtTop}}$ ,  $H_{\text{DoserAssembly}}$ , and  $H_{\text{CdcFloatValve}}$ . Originally, the code would position the bottom of Constant Head Tanks slightly above the lever arm, which was incorrect. After recalculation, it was determined that the height of the Constant Head Tanks should be approximately at the same height as the top of the

lever arm, whereas the *float valve holes* of the Constant Head Tanks should be placed slightly above the lever arm. The variable H.DoserAssembly was also redefined by reducing it 3 times because it will allow more accurate display of the height of the CHT. The z-coordinate therefore is changed from ZW.CdcFloatValveOrifice to ZW.CdcCht. Figure 11 shows the modified code used to change the z-coordinate of the Constant Head Tanks as described above. Figure 12 shows the view of the CHT on the platform wall after the code was changed.

$$\begin{aligned}
 ZW_{CdcCht} &= (Z_{EtTop} + H_{DoserAssembly} = \bullet) && \text{End of doser tube elevation at zero flow. (also fluid level in constant head tank)} \\
 ZW_{CdcCht} &= Z_{EtTop} + H_{DoserAssembly} && \text{Update as of October 2014:} \\
 &&& \text{The Dosing for coagulant does not need to happen at the elevation lever arm (which is the top of the entrance tank) and can instead} \\
 &&& \text{the height of the rapid mix pipe at the bottom of the LFOM. For n coagulant at the elevation of the walkway.} \\
 Z_{CdcFloatValveOrifice} &= ZW_{CdcCht} + H_{CdcFloatvalve} = \bullet && + \\
 Z_{CoagulantOutlet} &= Z_{CdcFloatValveOrifice} + H_{CoagTankAboveHeadTank} = \bullet && \text{This is the height of the outlet from the stock tanks} \\
 Z_{CoagulantTankBottom} &= Z_{CoagulantOutlet} - B_{StockOutlet} = \bullet && \text{This is the height of the coagulant stock tank base}
 \end{aligned}$$

$$\text{CHT}_{Origin} = \begin{pmatrix} \text{ChemPlatform}_{Origin_0} + \text{ChemPlatform}_{Dimensions_0} + T_{PlantWall} + \frac{1}{2}D_{CHT} \\ \text{ChemPlatform}_{Origin_1} - \frac{1}{2}D_{CHT} + \text{ChemPlatform}_{Dimensions_1} - T_{PlantWall} \\ ZW_{CdcCht} \end{pmatrix}$$

Figure 11: The z-coordinate of the CHT was changed from Z.CdcFloatValveOrifice to ZW.CdcCht

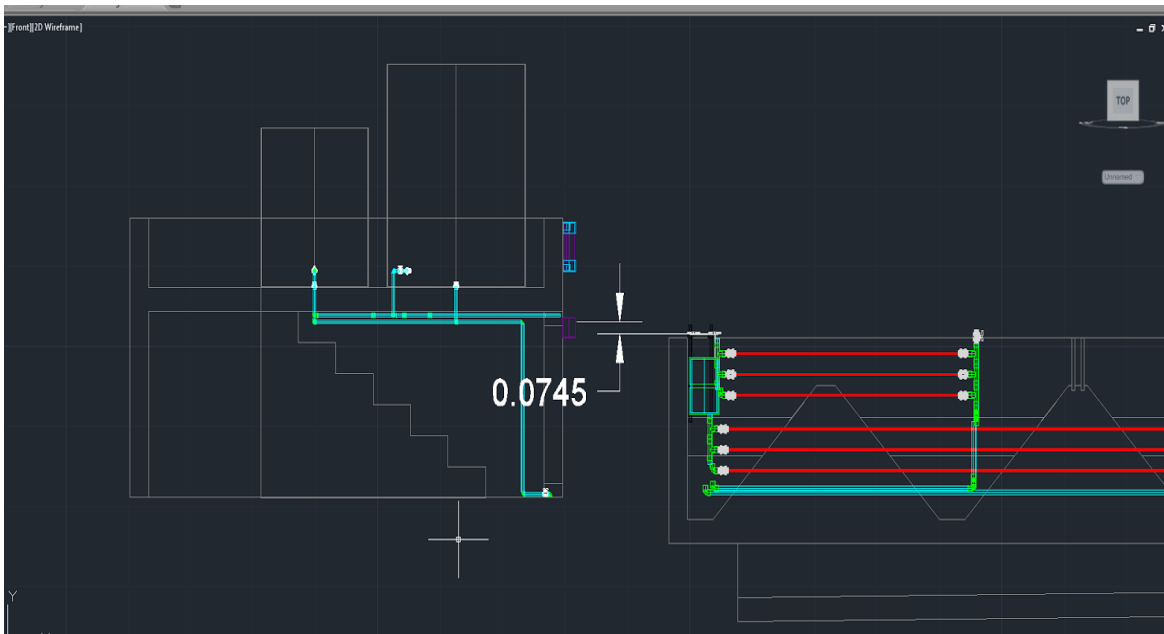

Figure 12: Front-view of the CDC system with modified CHT z-coordinate



The original diameter of the CHT was 30 cm, which was much bigger than what it should have been. The value of the diameter was redefined to be 10 cm and all the other parameters that were used to draw the CHT were changed proportionally. Two more CHT were also added to the drawing. Figure 13 shows the modification to the code to scale the CHT to their proper size. Figure 14 shows the CAD drawing with the added CHT.

$$\text{CHT1} := \text{ConstantHeadTankF} \left[ \text{CHT}_{\text{Origin}}, \begin{pmatrix} 90 \\ 0 \\ 90 \end{pmatrix} \text{deg}, \frac{D_{\text{CHT}}}{2}, H_{\text{CHT}}, T_{\text{CHTwall}}, .75 \cdot H_{\text{CHT}}, \frac{1}{3} \text{in}, \frac{1}{3} \text{in}, \frac{1}{3} \text{in}, \frac{1}{3} \text{in} \right]$$

$$\text{CHT2} := \text{ConstantHeadTankF} \left[ \text{CHT2}_{\text{Origin}}, \begin{pmatrix} 90 \\ 0 \\ 90 \end{pmatrix} \text{deg}, \frac{D_{\text{CHT}}}{2}, H_{\text{CHT}}, T_{\text{CHTwall}}, .75 \cdot H_{\text{CHT}}, \frac{1}{3} \text{in}, \frac{1}{3} \text{in}, \frac{1}{3} \text{in}, \frac{1}{3} \text{in} \right]$$

Figure 13: Modification to the CHT dimension

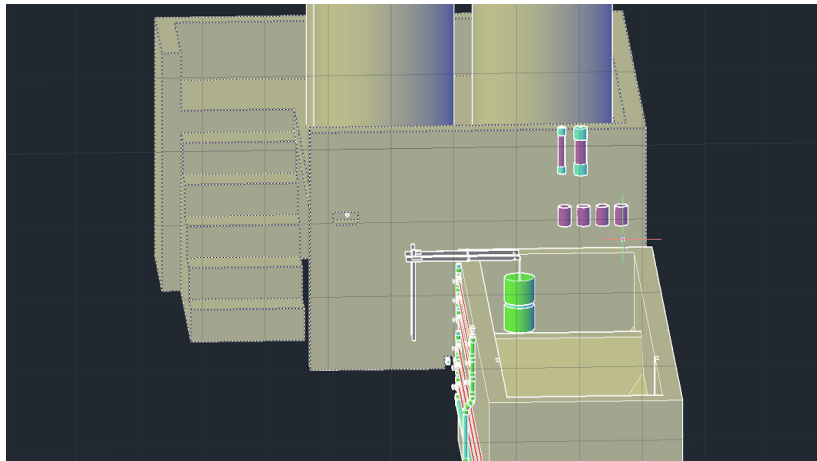

Figure 14: CDC drawing with two CHT added

5/6/2015

Changes were made to the sedimentation tanks file. The variable H.WalkwayToTankWall no longer exists. The height of the stairs, H.ChemStairs, depends on H.WalkwayToTankWall. Therefore, the  $-H_{\text{Sed}} + H_{\text{WalkwayToTankWall}}$  component of H.ChemStairs was changed into Z.Walkway. Figure 15 shows the MathCAD code for the modification. All changes to the CDC design code so far this semester were committed to the server under the following files: *ChemStockTanksAC\_t1428*, *CdcAC\_t1428* and *ExpertInputs\_t1428*.

$$H_{\text{ChemStairs}} := \text{CoagTank}_{\text{Origin}_2} - T_{\text{PlantWall}} - Z_{\text{Walkway}}$$

Figure 15: Redefinition of the variable H.ChemStairs

## Challenges

3/6/2015

The drawing functions as well as the actual design of the Chemical Dose Controller are complicated since the variables' origins are all interrelated and dependent on each other. Therefore, modification to drawing the Chemical Storage Tanks platform was challenging as it was first picked up. The origin specification needed to be reviewed thoroughly.

3/20/2015

Pictures from picasa did not provide much information on affects the structure of the pipes in CDC. There is not a method to formulate the design code for the CDC pipes yet. Cooperation with senior team members will be made to improve understanding of the drawing functions.

3/27/2015

The modified platform does not provide enough space between the Chemical Storage Tanks and the platform walls. Adjustment needs to be made to various origin points. Although many origin points depend on other variables, the code was written that most variables were hard coded and could be very confusing.

4/10/2015

The mounting board of the Constant Head Tanks should be removed and the Constant Head Tanks needed to be repositioned such that it attaches to a wall. Careful examination of the rotation angle as well as the origin points needed to be performed.

4/14/2015

The position of the CHT and calibration columns were wrong as they should have been on the Chemical Storage Tank platform walls instead of on the wall in between the platform and the entrance tanks. Since the changes cannot be made by simply rotating the objects through axes, careful calculation should be made to redetermine the exact x- and y-coordinates of the CHT and calibration columns.

4/19/2015

The variable, Z.CdcFloatValveOrifice did not exist within the CDC file nor the ExpertInput file. Since the CHT origin z-coordinate depended on the variable Z.CdcFloatValveOrifice, it needed to be located and a close examination on why that variable was used should be made.

4/23/2015

The diameter of the CHT was redetermined to be 30 cm. Careful examinations should have been made to determine what other dimensional parameters of the CHT needed to be changed proportionally when the diameter was modified.

5/4/2015

The orientation of the lever arm was incorrect and the lever arm had to be located right above the platform hole next to the entrance tank. Calculations were done and it was determined that both the origin and the drawing functions had to be redefined. All parts of the CDC were rotated by -90 degrees such that it would face the right direction. Their x- and y-coordinates of different parts were also changed. Nonetheless, the attempt was not successful. Recalculation to of the origin and rotation will be needed. No changes to the design code of the lever arm were committed to the server. Figure 16 shows the modification made to change the origins of the Lever Arm variables. Figure 17 shows the changes made to rotate the Lever Arm parts in drawing functions. Figure 18 shows the CAD drawing based on the above modified code.

$$\begin{aligned}
 \text{LAOrigin} &:= \begin{pmatrix} \text{EtOrigin}_0 - L_{\text{Et}} + S_{\text{EtFloat}} + \text{ConRadius}(\text{ND}_{\text{EtFloat}}) \\ \text{EtOrigin}_1 + \text{ConRadius}(\text{ND}_{\text{EtFloat}}) + \frac{S_{\text{EtFloat}}}{2} - L_{\text{CdcLever}} + T_{\text{PlantWall}} \\ Z_{\text{EtTop}} + \frac{D_{\text{LABOriginToLAOriginZ}}}{2} \end{pmatrix} & \text{LA}^2\text{Origin} &:= \begin{pmatrix} \text{LAOrigin}_0 - \text{ConRadius}(\text{ND}_{\text{EtFloat}}) - \frac{S_{\text{EtFloat}}}{2} \\ \text{LAOrigin}_1 \\ \text{LAOrigin}_2 \end{pmatrix} \\
 \text{LADtCenter} &:= \begin{pmatrix} \text{LAOrigin}_0 - (L_{\text{LAOriginToDtCenterX}}) \\ \text{LAOrigin}_1 - \frac{L_{\text{LAOriginToDtY}}}{2} \\ \text{LAOrigin}_2 + (L_{\text{LAOriginToDtZ}}) + H_{\text{LeverArm}} \end{pmatrix} & \text{LA}^2\text{DtCenter} &:= \begin{pmatrix} \text{LA}^2\text{Origin}_0 - (L_{\text{LAOriginToDtCenterX}}) \\ \text{LA}^2\text{Origin}_1 - \frac{L_{\text{LAOriginToDtY}}}{2} \\ \text{LA}^2\text{Origin}_2 + (L_{\text{LAOriginToDtZ}}) + H_{\text{LeverArm}} \end{pmatrix} \\
 \text{FloatOrigin} &:= \begin{pmatrix} \text{LAOrigin}_0 + \frac{W_{\text{LeverArm}}}{2} + L_{\text{CdcLever}} \\ \frac{(\text{LAOrigin}_1 + \text{LA}^2\text{Origin}_1)}{2} \\ Z_{\text{FloatTop}} - \text{CapThickness}(\text{ND}_{\text{EtFloat}}) \end{pmatrix} \\
 \text{Slider1Origin} &:= \begin{pmatrix} \text{LAOrigin}_0 - \frac{L_{\text{LAOriginToDtY}}}{2} - H_{\text{Slider}} \\ \text{LAOrigin}_1 - H_{\text{Slider}} + W_{\text{Slider}} \\ \text{LAOrigin}_2 + H_{\text{LeverArm}} + W_{\text{Slider}} \end{pmatrix} = \begin{pmatrix} -7.968 \\ 6.306 \\ 2.343 \end{pmatrix} \text{ m} & \text{Slider}^2\text{Origin} &:= \begin{pmatrix} \text{LA}^2\text{Origin}_0 - \frac{L_{\text{LAOriginToDtY}}}{2} - H_{\text{Slider}} \\ \text{LA}^2\text{Origin}_1 - H_{\text{Slider}} + W_{\text{Slider}} \\ \text{LA}^2\text{Origin}_2 + H_{\text{LeverArm}} + W_{\text{Slider}} \end{pmatrix}
 \end{aligned}$$

Figure 16: MathCAD codes of the Lever Arm origin redefinition

$$\begin{aligned} \text{Slider1FirstSide} &:= \text{BoxF} \left[ \text{Slider1Origin}, \begin{pmatrix} \text{Slider1Origin}_0 + L_{\text{Slider}} \\ \text{Slider1Origin}_1 + W_{\text{Slider}} \\ \text{Slider1Origin}_2 - H_{\text{Slider}} \end{pmatrix}, \begin{pmatrix} 0 \\ 0 \\ 0 \end{pmatrix} \text{deg} \right] & \text{Slider2FirstSide} &:= \text{BoxF} \left[ \text{Slider2Origin}, \begin{pmatrix} \text{Slider2Origin}_0 + L_{\text{Slider}} \\ \text{Slider2Origin}_1 + W_{\text{Slider}} \\ \text{Slider2Origin}_2 - H_{\text{Slider}} \end{pmatrix}, \begin{pmatrix} 0 \\ 0 \\ 0 \end{pmatrix} \text{deg} \right] \\ \\ \text{Slider1TopSide} &:= \text{BoxF} \left[ \text{Slider1Origin}, \begin{pmatrix} \text{Slider1Origin}_0 + H_{\text{Slider}} \\ \text{Slider1Origin}_1 + L_{\text{Slider}} \\ \text{Slider1Origin}_2 - W_{\text{Slider}} \end{pmatrix}, \begin{pmatrix} -90 \\ 0 \\ 0 \end{pmatrix} \text{deg} \right] & \text{Slider2TopSide} &:= \text{BoxF} \left[ \text{Slider2Origin}, \begin{pmatrix} \text{Slider2Origin}_0 + H_{\text{Slider}} \\ \text{Slider2Origin}_1 + L_{\text{Slider}} \\ \text{Slider2Origin}_2 - W_{\text{Slider}} \end{pmatrix}, \begin{pmatrix} -90 \\ 0 \\ 0 \end{pmatrix} \text{deg} \right] \\ \\ \text{Slider1SecondSide} &:= \text{BoxF} \left[ \begin{pmatrix} \text{Slider1Origin}_0 + H_{\text{Slider}} \\ \text{Slider1Origin}_1 \\ \text{Slider1Origin}_2 \end{pmatrix}, \begin{pmatrix} \text{Slider1Origin}_0 + H_{\text{Slider}} + W_{\text{Slider}} \\ \text{Slider1Origin}_1 + L_{\text{Slider}} \\ \text{Slider1Origin}_2 - H_{\text{Slider}} \end{pmatrix}, \begin{pmatrix} -90 \\ 0 \\ 0 \end{pmatrix} \text{deg} \right] & \text{Slider2SecondSide} &:= \text{BoxF} \left[ \begin{pmatrix} \text{Slider2Origin}_0 + H_{\text{Slider}} \\ \text{Slider2Origin}_1 \\ \text{Slider2Origin}_2 \end{pmatrix}, \begin{pmatrix} \text{Slider2Origin}_0 + H_{\text{Slider}} + W_{\text{Slider}} \\ \text{Slider2Origin}_1 + L_{\text{Slider}} \\ \text{Slider2Origin}_2 - H_{\text{Slider}} \end{pmatrix}, \begin{pmatrix} -90 \\ 0 \\ 0 \end{pmatrix} \text{deg} \right] \end{aligned}$$

Figure 17: MathCAD functions to rotate the Lever Arm components

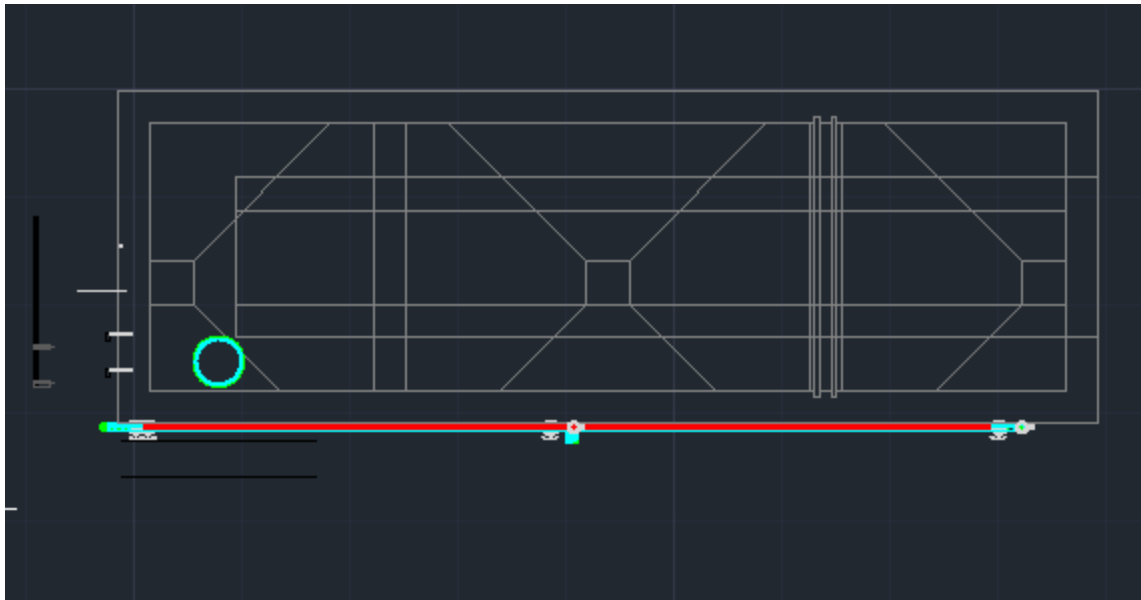

Figure 18: AutoCAD drawing of the entrance tank with the modified Lever Arm components

## Future Goals:

Future teams should continue to update the design of the Chemical Dose Controller code and strive to improve the code efficiency. They should improve the CDC design code by developing a more logical variable dependency, which will simplify the design code modification process. Variables or functions that no longer contribute to the plant AutoCAD drawing should also be identified and removed. Future teams should also focus on accomplishing two specific tasks. First, efforts should be made to finalize the drawing functions of the lever arm. Second, the origins for the pipes used in the Chemical Dose Controller should be determined and efforts should be put in to create functions that draw out those pipes. Through continuous efforts of the CDC team, the design code for the Chemical Dose Controller

will be precise and easily understood. The AutoCAD drawing produced will reflect the most up-to-date design of the CDC in the AguaClara water treatment plants.