

# **Design of a Low-cost Solar Tracking Photo-Voltaic (PV) Module and Wind Turbine Combination System**

S. Lakeou (1), E. Ososanya (1) , B.O. Latigo (2), W. Mahmoud (1)

(1) Department of Electrical Engineering

(2) Dean, School of Engineering and Applied Sciences  
University of the District of Columbia

## **I. Introduction**

This paper describes the design of a low cost, 0.9kW solar tracking photo-voltaic (PV) array system as part of an undergraduate senior project. The solar tracking system is interfaced with a 1kW wind turbine, a deep cycle battery storage system, a charge controller and an inverter. Solar tracking is realized through “field” programmable complex digital circuit and alternatively with a low cost solar radiation sensing transducer consisting of green light emitting diodes (LED). Actuation of the panel tilt for azimuth tracking and rotation of the panel for solar tracking are operated with a gear motor-based control system for adjusting the PV mount system’s position so as to collect maximum solar radiation. The gear motor controller module is built with state-of-the-art, low-cost digital logic circuit with built-in flexibility to accommodate seasonal position adjustments of the PV mounts. The design includes a computer remote access for monitoring the power generation of the system. The system is configured for an insolation (solar radiation) condition specific to the location of the system at the University of the District of Columbia in Washington, DC, but could be easily configured for any other location.

## **II. Background**

As depicted in Figure 1, the position of the sun with respect to that of the earth changes in a cyclic manner during the course of a calendar year. Tracking the position of the sun in order to expose a solar panel to maximum radiation at any given time is the main purpose of a solar tracking PV system.

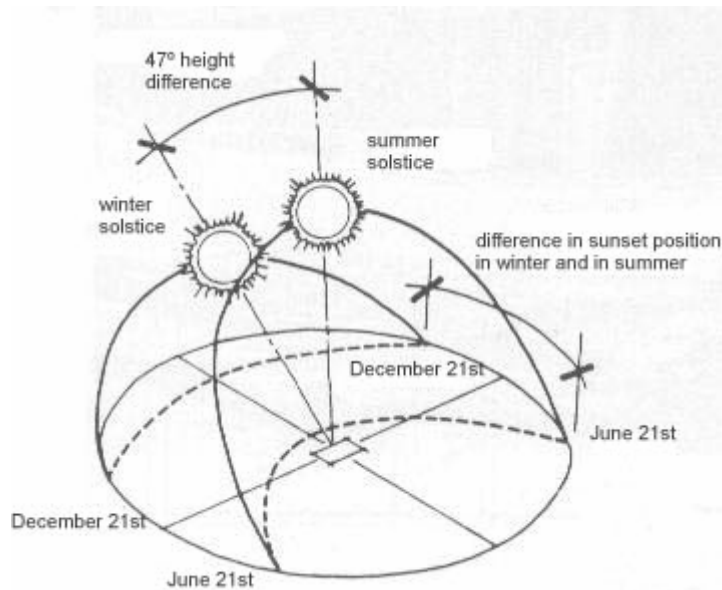

**Figure 1 (a). Illustration of the summer and winter solstices**

**Sun Path Diagram for 40 Degrees N Latitude**

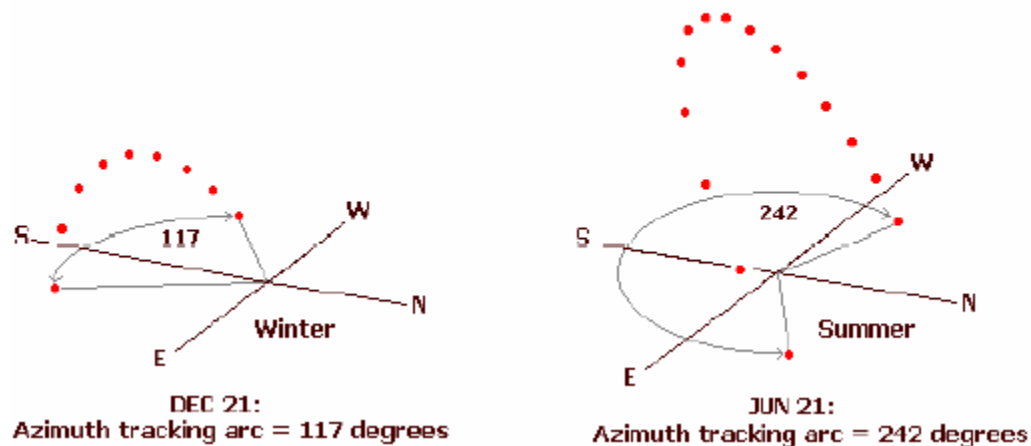

**Figure 1 (b). Sun Path Diagram for 40° N Latitude During Winter and Summer Solstices**

For many years, several energy companies and research institutions have been performing solar tracking for improving the efficiency of solar energy production. A variety of techniques of solar energy production used have proven that up to 30% more solar energy can be collected with a solar tracker than with a fixed PV system<sup>1</sup>. The cost of such systems is however still very prohibitive for the average consumer or for a small-scale application. The current work shows that a comparable system can be designed at a much lower cost particularly for academic institutions. In addition, the solar trackers currently available are generally not programmable for location flexibility. Moving a system from the northern hemisphere to the southern hemisphere, coupled with latitudinal and longitudinal position changes, can result in considerable design changes to the tracker's control circuitry.

A typical solar tracking PV system must be equipped with two essential features:

- a) Azimuth tracking for adjusting the tilt angle of the surface of the PV array during changing seasons; and
- b) Daily solar tracking for maximum solar radiation incidence to the PV array.

The Tilt Angle  $\theta$  of a PV system required at any given time in the year can be expressed as a function of the seasonal Sun's Altitude  $\phi$  as follows:

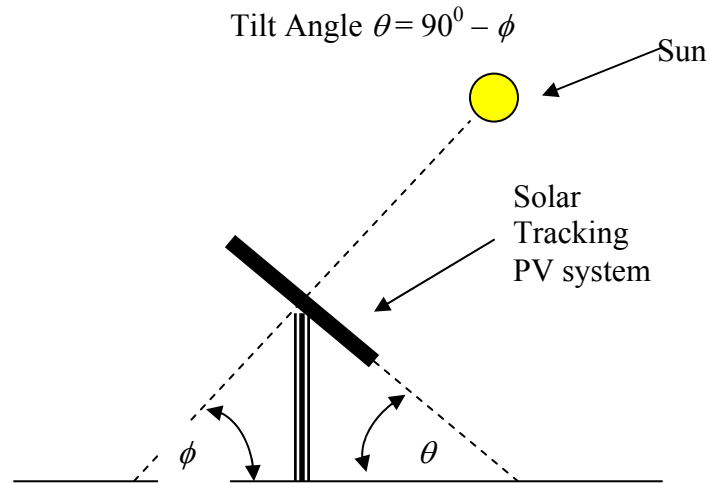

**Figure 2. Tilt Angle  $\theta$  of a PV array**

Before the advent of solar tracking, fixed solar panels have been positioned within a reasonable tilt range based on the latitude of the location. A rule of thumb is to select a tilt angle of within  $\pm 15^\circ$  of the latitude depending on whether a slight winter or summer bias is preferred in the system. The PV array would face “true south” in the northern hemisphere and “true north” in the southern hemisphere. Note that the true south and the true north directions differ from the magnetic south and north direction usually obtained with a compass. Several reference tables are readily available for making the appropriate tilt adjustments<sup>2</sup>. Solar tracking is best achieved when the tilt angle of the tracking PV array system is synchronized with the seasonal changes of the sun's altitude and with the geographical insolation level for optimized solar tracking during the day<sup>3</sup>. The following three examples show the tilt angle and the insolation level (expressed in Sun Hours/day) disparities between the geographic locations.

Two locations from the northern hemisphere, Washington, DC and Addis Ababa, Ethiopia and one from the southern hemisphere, Cape Town, South Africa are selected for illustration. Note that the average insolation for Addis Ababa is particularly high due to its proximity to the equator. The corresponding tilt angles and array orientations are summarized in Figure 3.

<u>Washington, DC</u> Average Insolation: 4.23				<u>Addis Ababa, Ethiopia</u> Average Insolation: 5.84				<u>Cape Town, South Africa</u> Average Insolation: 4.5			
Month	Sun Altitude	Array Tilt	Array Points to:	Month	Sun Altitude	Array Tilt	Array Points to:	Month	Sun Altitude	Array Tilt	Array Points to:
JAN	32	58	South	JAN	61	29	South	JAN	77	13	North
FEB	41	49	South	FEB	70	20	South	FEB	68	22	North
MAR	52	38	South	MAR	81	9	South	MAR	57	33	North
APR	64	26	South	APR	87	3	North	APR	45	45	North
MAY	72	18	South	MAY	79	11	North	MAY	37	53	North
JUN	75	15	South	JUN	76	14	North	JUN	34	56	North
JUL	72	18	South	JUL	79	11	North	JUL	37	53	North
AUG	64	26	South	AUG	87	3	North	AUG	45	45	North
SEP	52	38	South	SEP	81	9	South	SEP	57	33	North
OCT	40	50	South	OCT	69	21	South	OCT	69	21	North
NOV	32	58	South	NOV	61	29	South	NOV	77	13	North
DEC	29	61	South	DEC	58	32	South	DEC	80	10	North

Figure 3. Tables showing the tilt angle disparity *versus* location

### III. Description of the Proposed Controller Design

#### III.a. Field Programmable Controller Design Specifications

The programmable controller is expected to achieve the following:

Two 24V, DC gear motors with selected gear ratio, control the rotation of a dual-axis PV array along and the azimuth (tilt) tracking axis  $X$ , and the solar tracking axis  $Y$  as shown in Figure 4. The controller must interface with the DC motors through an H-Bridge structure. A complex programmable logic device (CPLD) feeds the H-Bridge with two signals, S for activating the motor and D for the direction of the rotor movement. The duration of the signal S is calculated based on the amount of rotation required for every angular step and on the gear ratio selected for the gear motor, and the panel-to-motor transfer gear ratio.

Initially, once the location is selected, the azimuth angle range is determined with a tilt angle  $\theta$  calculator, and the angular step value is subsequently set. The total number of tilt steps is 12 (6 in each direction) for covering the whole calendar year. During the course of the year, the array will be tilted around the  $X$ -axis progressively from **June 21** to **December 21** in one direction and from **December 22** to **June 20** in the opposite direction.

For a simple tracking system, the daily solar tracking is achieved by rotating the array about the solar tracking axis  $Y$ , by equal incremental angular steps  $\Delta\varphi = 15^\circ$ . It is to be noted that this proposed angular step does not reflect the actual angular step to be performed every month. In fact, the angular step varies from month to month and is location dependent. The programmable nature of the proposed design can easily account for these variations. The number of angular

steps covered during the day is determined seasonally in order to cover the maximum insolation for the selected location. At the end of each day, the system is returned to its standby position. Hence, for a location such as Washington, DC, where the average insolation is 4.23 Sun Hours/Day, the number of steps will range from 12 per day on **June 21** to 6 per day on **December 21**, with a respective start time of 6:00 am and 9:00 am. After **December 22**, the number of steps will increase by 1 on the proper day each month until the following June 21.

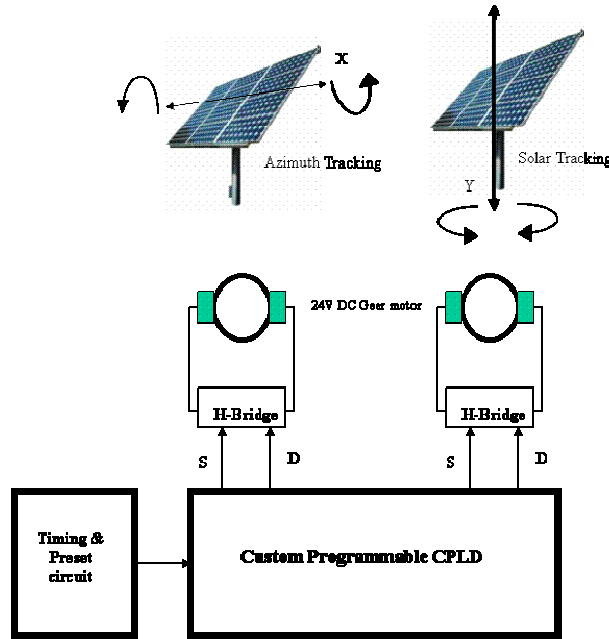

**Figure 4. Field Programmable Controller System Diagram**

The following example illustrates the aforementioned tracking scheme:

Location	Range of Array Tilt Angle $\theta$	( $\pm$ ) Azimuth Tracking Angular Step	Solar Tracking Angular Step on June 21 $\Delta\phi$	No. of Solar Tracking Steps on June 21	No. of Solar Tracking Steps on Dec 21
Washington, DC	$43^\circ$	$43^\circ/6=7^\circ$	$180^\circ/12=15^\circ$	12 Start at 6:00 am	6 Start at 9:00 am

### III.b. Functional Diagram and Implementation of the Field Programmable Controller Circuit

The electronic design is implemented with a complex programmable logic device (CPLD) from Xilinx, Inc. The selected CPLD is an 84-pin, Xilinx XC95108 with 2400 usable gates and 69 user definable inputs and outputs.<sup>4</sup> The design entry is performed with Xilinx's Integrated Software Environment ISE 8.1i design tool.<sup>5</sup> The entry can be easily achieved either through a VHDL or with a Finite State Machine description of the circuit specifications. The design implementation process includes the following steps:

- Schematic capture or finite state machine (FSM) description of the design using the Integrated Software Environment (ISE) design environment of Xilinx or description of

the design using the VHDL code from ISE. In the latter case, entities are defined for every component of the design;

- Simulation of the circuit using Modelsim;
- Synthesis of the design; and
- Programming of the XC95108 by downloading the design.

The basic functional block of the circuit is described in Figure 5.

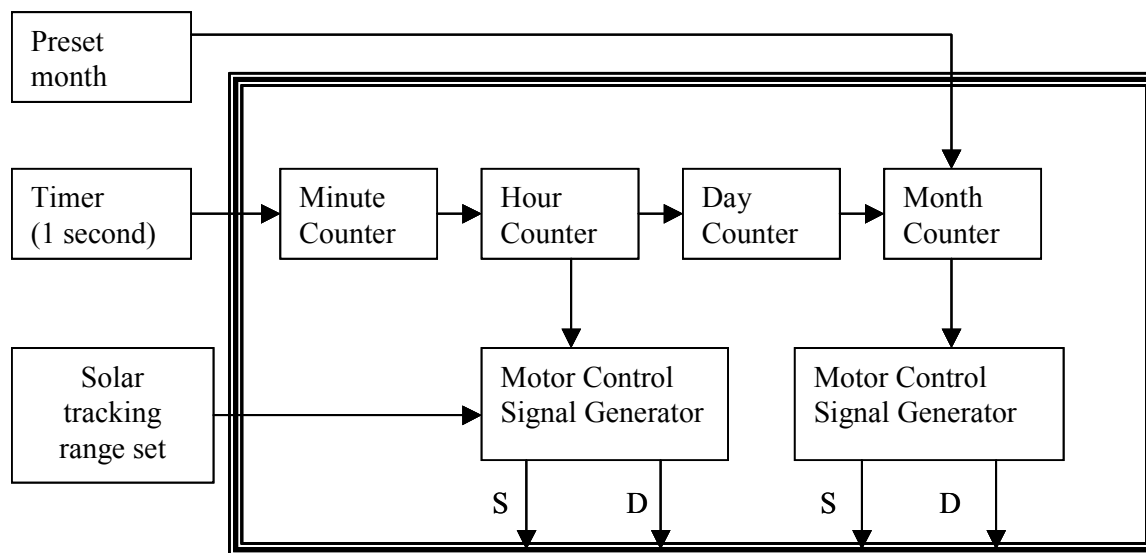

**Figure 5. Functional description of the CPLD (enclosed in the large box)**

The timer circuit consists of a 555 timer delivering a TTL signal of 1-second period. The preset month will be required if the system is installed in a month different that June. The system is preset to start on June 21 at 6:00 am.

### III.c. PC-Based Controller Design

The PC-based controller depicted in Figure 6 uses a low cost analog to digital (ADC) digital to analog (DAC) interface circuit built at the University of the District of Columbia.<sup>6</sup> The circuit interfaces with an 8-point radiation sensor circuit. The radiation-to-electrical-voltage transducer is a green light emitting diode (LED), which generates an electric voltage of 1.67V under direct sunlight. 8 LED's are positioned on a semicircular support. The LED has a very acute directional sensitivity to sunlight. A slight angular displacement, less than  $10^0$ , of the LED from direct sunlight results in a 20% decrease of the generated voltage.

Solar tracking is achieved by software written in PC assembly language or other high level language such as C++ to query the radiation level at the sensors and by sending digital signals S and D to each H-bridge. Each LED is sensed periodically and appropriate S and D signals are sent to activate the appropriate DC motor to move the PV array to the direction of the highest level of voltage sensed.

The azimuth tracking follows the same scheme described for the field programmable design. The angular steps are provided by sending out on the I/O digital bus, single digit signals for S and D, the width of the signal S is timed through software to correspond to the time required to provide the adequate rotation of the 24V DC motor in the selected direction.

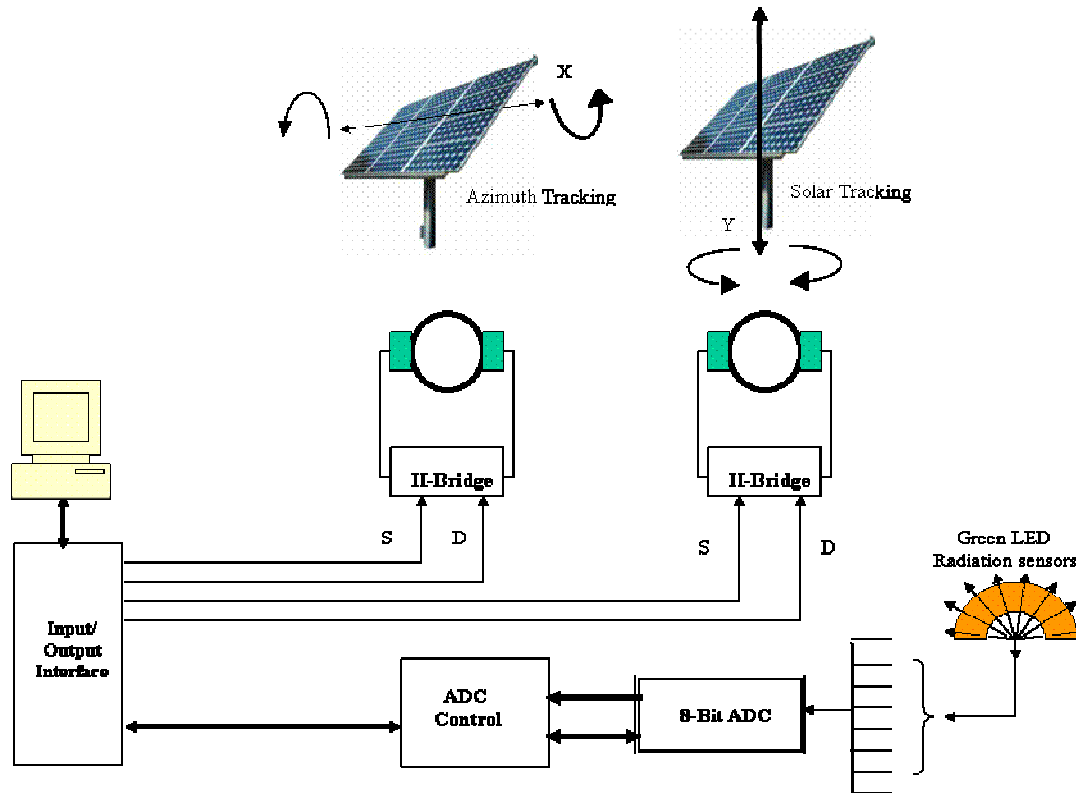

Figure 6. PC-Based Controller Diagram

#### IV. Main Advantages of the Proposed Controller Design

(a) **Reduced Cost** A cursory cost comparison between the proposed controller design approaches and those currently available on the market shows that the controller circuitry costs around \$1,000.<sup>1</sup> The cost excludes the price of the frame of the PV array and all other accessories, such as power supply for the gear motors. The typical price of a 12-module solar tracking PV array is around \$2,000.<sup>1</sup>

Field Programmable Controller		PC-Based Controller with Radiation Sensors	
Component	Price (\$)	Component	Price (\$)
Xilinx XC95108 CPLD	35	ADC/DAC board	150
H-bridge (2)	40	Sensors	7
Timer circuit	5	H-bridge (2)	40
<b>Total</b>	<b>80</b>	<b>Total</b>	<b>197</b>

With the exclusion of miscellaneous items, the cost involved in the proposed design is summarized in the above table. It is assumed that in most educational institutions, educational discounts through university programs can be obtained for defraying the cost relative to design tools<sup>7</sup> such as the Xilinx's ISE 8.1i package.<sup>8</sup>

(b) **Flexibility** The stand alone, field programmable controller design is perfectly suited to remote area applications. The CPLD can be re-programmed for any desired location. The array can therefore be a **mobile power station** with minimal design change. If properly designed to self power the 24V DC motors, the solar tracker system equipped with a field programmable controller can operate indefinitely with little supervision.

The PC-based controller can be equipped with a power monitoring system. The PC can be interfaced with a data acquisition board such as the NI-DAQ board from National Instruments and a simple LabView<sup>9</sup> program can be written to monitor the power generated by the PV array.

### V. Application to a Solar PV and Wind Turbine Combination System

The sizing<sup>10</sup> of the PV modules and the battery bank is done for generating 900W over a period of 5 hours per day and 7 days per week. This requires 31500 WH per week and 1641 Amp Hours per week. The power is needed for driving a Grundfos 11-SQL-2 pump which is rated at 30-300V DC and 90-240V AC 50/60Hz.

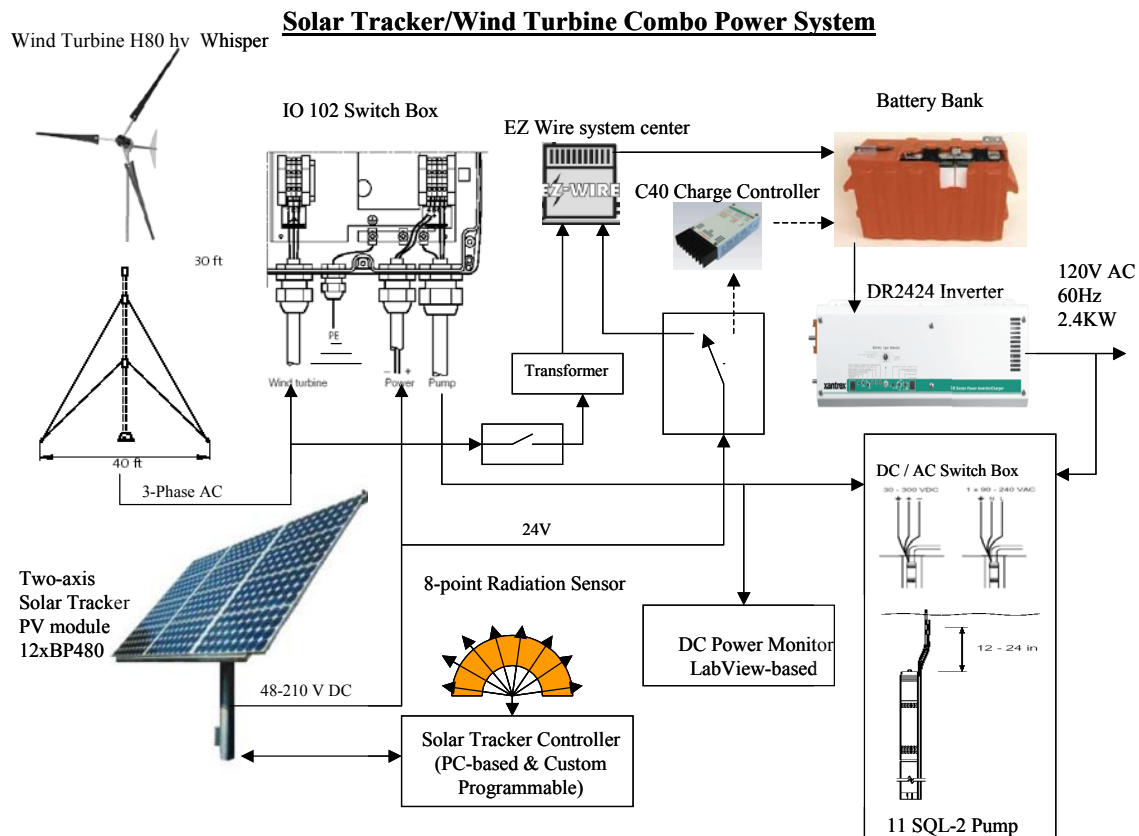

Figure 7. Solar Tracker with Wind Turbine Combo



The system shown in Figure 7 comprises the following components:

- Whisper H80 hv (high voltage) wind turbine from Southwest Windpower
- Wattsun 125 AZ, dual-axis solar tracker with two 24V DC motors
- Xantrex/Trace C40 charge controller
- Xantrex/Trace DR2424 inverter (120V, 60Hz, 2.4KW)
- Grundfos 11 SQL-2 pump (40-300VDC, 90-240V AC)
- Miscellaneous connectors

The Wind turbine and the solar tracker array are connected to an IO102 breaker box supplied by Grundfos. The IO102 box converts the 3-phase AC voltage from the wind turbine and combines it to the DC voltage generated by the solar array.

The Grundfos 11-SQL-2 pump operates both in DC and AC. A battery charger/controller and an inverter can therefore be connected to the system for allowing self powering, on demand, during evening hours. The battery charging can either be accomplished with the PV array alone or with a combination of the wind turbine and solar array and the use of the EZ-Wire system combined with a transformer from Southwest Windpower. The transformer is required to step down from the high voltage 150AC to a lower voltage compatible with the EZ-Wire System.

## VI. Conclusion and Acknowledgements

The proposed controller design approaches are cost effective and flexible. The approaches are however better appreciated in environments such as academic or research institutions, where the software and hardware development tools are generally readily available without added cost. From our search results, we have not encountered a design of controller of solar tracker PV array which includes a low cost CPLD. It is hoped that the approach will incite further interest both in academia and in industry.

The following companies are acknowledged for their gracious donations:

- **BP Solar** ([www.bpsolar.com](http://www.bpsolar.com)), for donating 12, **BP-480** PV modules;
- **Grundfos**, ([www.grundfos.com](http://www.grundfos.com)) for donating a high voltage **H80 Whisper** Wind Turbine, a **IO 102 breaker box**, a bank of **solar modules** and a **11-SQL-2 pump** ; and
- **Xantrex** ([www.xantrex.com](http://www.xantrex.com)) for donating a **C40** charge controller and a **DR2424** Inverter.

In addition, special acknowledgements go to the following students who have helped in the assembly of the solar panels and the wind turbine:

From the program of civil engineering : Folayemi Akinfe

From the program of electrical engineering: Donnel Harris, Hiep Trung Lee

From the program of mechanical engineering: Oluwakayode Bamiduro, Chiedu A. Chibogu, Mario Da- Rocha, Daykaker Karter, Steven Omoijunanfo, Sunday O. Omotosho, Brittany E. Towns.

## Bibliography

1. <http://wattsun.com/resources.html>
2. <http://www.ngdc.noaa.gov/seg/geomag/jsp/struts/calcDeclination>
3. <http://solar4power.com/solar-power-global-maps.html>
4. XC95108 properties at [http://xilinx.com/xlnx/xil\\_prodcat\\_product.jsp?title=xc9500\\_page](http://xilinx.com/xlnx/xil_prodcat_product.jsp?title=xc9500_page)
5. Xilinx ISE 8.1i Foundation in depth tutorial at [http://www.xilinx.com/ise/logic\\_design\\_prod/foundation.htm](http://www.xilinx.com/ise/logic_design_prod/foundation.htm)
6. Flexible prototype board design for ADC/DAC control: application to mini-projects, S. Lakeou, ASEE05 Proceedings
7. IBM PC Assembly Language & Programming, Peter Abel, Prentice-Hall
8. Xilinx University Program at <http://xilinx.com/univ/index.htm>
9. Labview at <http://www.ni.com/dataacquisition/>
10. <http://solar4power.com/solar-power-loads.html>