

How I built an electricity producing wind turbine

by [mdavis19](#) on September 17, 2008

Table of Contents

How I built an electricity producing wind turbine	1
Intro: How I built an electricity producing wind turbine	2
Step 1: Acquiring a generator	3
Step 2: Making the blades	3
Step 3: Building the hub	4
Step 4: Building the turbine mounting	5
Step 5: Build the tower base	6
Step 6: Paint all the wood parts	7
Step 7: The finished head of the wind turbine	7
Step 8: Build the charge controller	7
Step 9: Erect the tower	8
Step 10: Erect the wind turbine	9
Step 11: Connect the electronics	10
Step 12: Enjoy having power in the middle of nowhere	11
Step 13: How much did it cost?	12
Step 14: Update	13
Step 15: Update 2	13
Related Instructables	14
Comments	14

Intro: How I built an electricity producing wind turbine

Several years ago I bought some remote property in Arizona. I am an astronomer and wanted a place to practice my hobby far away from the terrible light pollution found near cities of any real size. I found a great piece of property. The problem is, it's so remote that there is no electric service available. That's not really a problem. No electricity equals no light pollution. However, it would be nice to have at least a little electricity, since so much of life in the 21st century is dependent on it.

One thing I noticed right away about my property is that most of the time, the wind is blowing. Almost from the moment I bought it, I had the idea of putting up a wind turbine and making some electricity, and later adding some solar panels. This is the story of how I did it. Not with an expensive, store-bought turbine, but with a home-built one that cost hardly anything. If you have some fabricating skills and some electronic know-how, you can build one too.

More details on [this project](#) and my other alternative energy projects including my [home-built solar panels](#), and my [home-built biomass gasifier](#) can be found on [my web site](#).



Step 1: Acquiring a generator

I started by Googling for information on home-built wind turbines. There are a lot of them out there in an amazing variety of designs and complexities. All of them had five things in common though:

1. A generator
2. Blades
3. A mounting that keeps it turned into the wind
4. A tower to get it up into the wind
5. Batteries and an electronic control system

I reduced the project to just five little systems. If attacked one at a time, the project didn't seem too terribly difficult. I decided to start with the generator. My online research showed that a lot of people were building their own generators. That seemed a bit too complicated, at least for a first effort. Others were using surplus permanent magnet DC motors as generators in their projects. This looked like a simpler way to go. So I began looking into what motors were best for the job.

A lot of people seemed to like to use old computer tape drive motors (surplus relics from the days when computers had big reel to reel tape drives). The best apparently are a couple of models of motor made by Ametek. The best motor made by Ametek is a 99 volt DC motor that works great as a generator. Unfortunately, they are almost impossible to locate these days. There are a lot of other Ametek motors around though. A couple of their other models make decent generators and can still be found on places like Ebay. This web site talks about the virtues and vices of various Ametek motors when used as generators. <http://www.tlgwindpower.com/ametek.htm>

I managed to score one of the good 30 volt Ametek motors off of Ebay for only \$26. They don't go that cheap these days. People are catching on to the fact that they make great wind generators. Other brands will work, so don't fret about the price Ameteks are going for. Shop wisely. Anyway, The motor I got was in good shape and worked great. Even just giving the shaft a quick turn with my fingers would light a 12 volt bulb quite brightly. I gave it a real test by chucking it up in my drill press and connecting it to a dummy load. It works great as a generator, putting out easily a couple hundred Watts with this setup. I knew then that if I could make a decent set of blades to drive it, it would produce plenty of power.

There is more information on how to choose a motor for use as a generator on my web site at http://www.mdpub.com/Wind_Turbine/

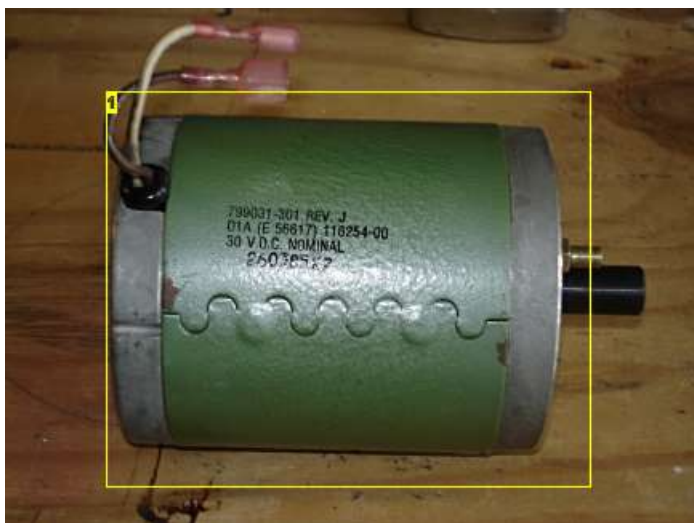

Image Notes

1. Surplus Ametek 30V tape drive motor bought on Ebay will be the generator.

Step 2: Making the blades

Blades and a hub to connect them to were the next order of business. More online research ensued. A lot of people made their own blades by carving them out of wood. That looked like an outrageous amount of work to me. I found that other people were making blades by cutting sections out of PVC pipe and shaping them into airfoils. That looked a lot more promising to me. This web site tells you how to make a set of blades for a small wind turbine using PVC pipe.

http://www.yougreendream.com/diy_pvc_blades.php

I followed their general recipe. I did things a little differently though. I used black ABS pipe since my local homecenter store just happened to have pre-cut lengths of it. I used 6 inch pipe instead of 4 inch and 24 inches long instead of 19 5/8. I started by quartering a 24 inch long piece of pipe around its circumference and cutting it lengthwise into four pieces. Then I cut out one blade, and used it as a template for cutting out the others. That left me with 4 blades (3 plus one spare).

I then did a little extra smoothing and shaping using my belt sander and palm sander on the cut edges to try to make them into better airfoils. I don't know if it's really much of an improvement, but it didn't seem to hurt, and the blades look really good (if I do say so myself).



Image Notes

1. Cut a piece of plastic pipe 6 inches in diameter and 24 inches long into quarters lengthwise. A jigsaw comes in handy for this.
2. Shape a blade out of each quarter.

Image Notes

1. I used a sander to round off the rough edges and shape them into better airfoils
2. These tabs are a problem. I learned the hard way that the blades will eventually break where the tab joins the body of the blade. I recommend not bothering making tabs.

Step 3: Building the hub

Next I needed a hub to bolt the blades to and attach to the motor. Rummaging around in my workshop, I found a toothed pulley that fit on the motor shaft, but was a little too small in diameter to bolt the blades onto. I also found a scrap disk of Aluminum 5 inches in diameter and 1/4 inch thick that I could bolt the blades onto, but wouldn't attach to the motor shaft. The simple solution of course was to bolt these two pieces together to make the hub. Much drilling, tapping and bolting later, I had a hub.



Image Notes

1. A toothed pulley that fits the shaft on the generator, but is too small to bolt the blades to. Solution: Bolt the two pieces together.
2. A disk of Aluminum large enough to bolt the blades to, but with no method to attach to the generator.



Image Notes

1. Holes drilled and tapped so the two pieces can bolt together to make the hub.
2. More holes drilled and tapped.

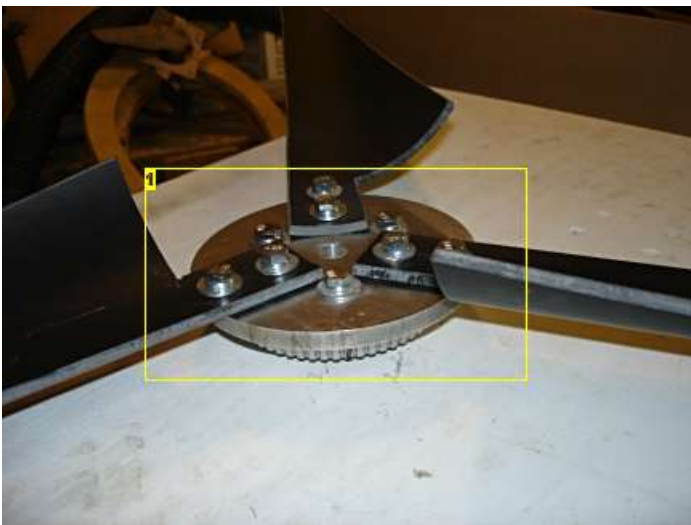

Image Notes

1. Here the two pieces are bolted together and the blades are bolted on.

Image Notes

1. Another view of the completed hub with the blades mounted.

Step 4: Building the turbine mounting

Next I needed a mounting for the turbine. Keeping it simple, I opted to just strap the motor to a piece of 2 X 4 wood. The correct length of the wood was computed by the highly scientific method of picking the best looking piece of scrap 2 X 4 off my scrap wood pile and going with however long it was. I also cut a piece of 4 inch diameter PVC pipe to make a shield to go over the motor and protect it from the weather. For a tail to keep it turned into the wind, I again just used a piece of heavy sheet Aluminum I happened to have laying around. I was worried that it wouldn't be a big enough tail, but it seems to work just fine. The turbine snaps right around into the wind every time it changes direction. I have added a few dimensions to the picture. I doubt any of these measurements is critical though.

Next I had to begin thinking about some sort of tower and some sort of bearing that would allow the head to freely turn into the wind. I spent a lot of time in my local homecenter stores (Lowes and Home Depot) brainstorming. Finally, I came up with a solution that seems to work well. While brainstorming, I noticed that 1 inch diameter iron pipe is a good slip-fit inside 1 1/4 inch diameter steel EMT electrical conduit. I could use a long piece of 1 1/4 inch conduit as my tower and 1 inch pipe fittings at either end. For the head unit I attached a 1 inch iron floor flange centered 7 1/2 inches back from the generator end of the 2X4, and screwed a 10 inch long iron pipe nipple into it. The nipple would slip into the top of the piece of conduit I'd use as a tower and form a nice bearing. Wires from the generator would pass through a hole drilled in the 2X4 down the center of the pipe/conduit unit and exit at the base of the tower. Brilliant! (if I do say so myself)

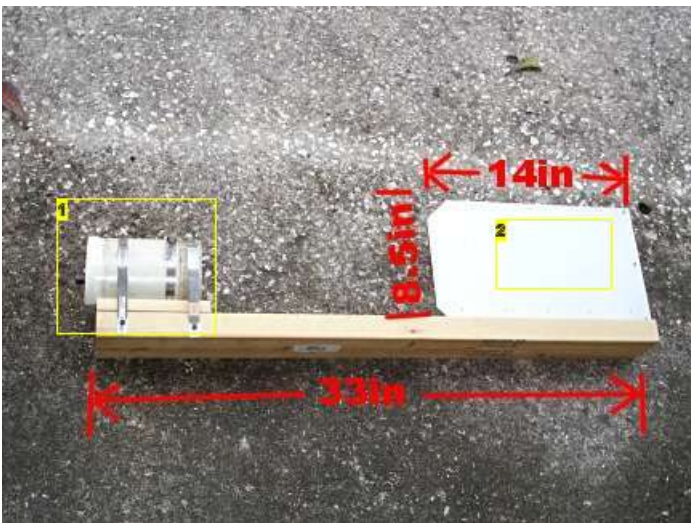

Image Notes

- 1. Piece of PVC pipe to protect the generator from the weather. Mounted with large hose clamps.
- 2. Random piece of sheet aluminum found on my junk pile used as a tail.

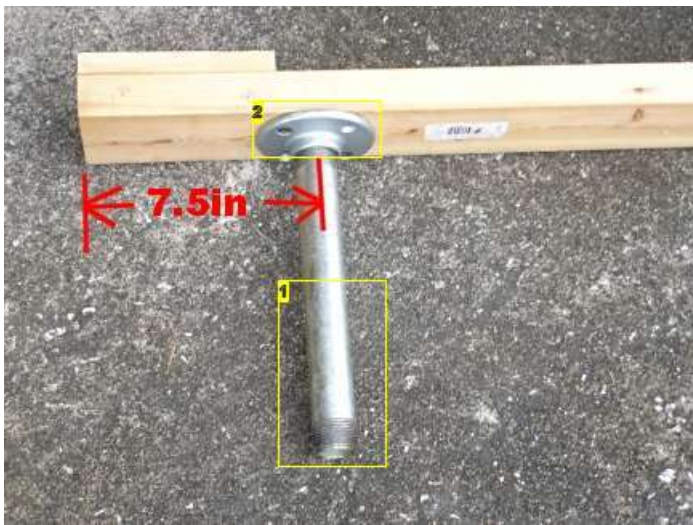

Image Notes

1. 1 inch steel pipe 10 inches long used as a bearing.
2. Floor flange screwed to underside of mounting board. A hole drilled through the board allows the wires from the generator to pass down the center of the flange and pipe.

Step 5: Build the tower base

For the tower base, I started by cutting a 2 foot diameter disk out of plywood. I made a U shaped assembly out of 1 inch pipe fittings. In the middle of that assembly I put a 1 1/4 inch Tee. The Tee is free to turn around the 1 inch pipe and forms a hinge that allows me to raise and lower the tower. I then added a close nipple, a 1 1/4 to 1 reducing fitting, and a 12 inch nipple. Later I added a 1 inch Tee between the reducer and the 12 inch nipple so there would be a place for the wires to exit the pipe. This is shown in a photo further down the page. I also later drilled holes in the wooden disk to allow me to use steel stakes to lock it in place on the ground.

The second photo shows the head and base together. You can begin to see how it will go together. Imagine a 10 foot long piece of steel conduit connecting the two pieces. Since I was building this thing in Florida, but was going to use it in Arizona, I decided to hold off on purchasing the 10 foot piece of conduit until I got to Arizona. That meant the wind turbine would never be fully assembled and not get a proper test until I was ready to put it up in the field. That was a little scary because I wouldn't know if the thing actually worked until I tried it in Arizona.

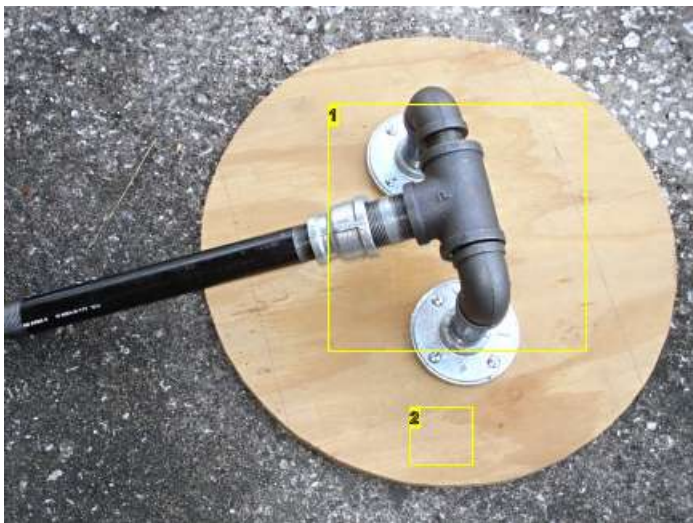

Image Notes

1. Hinge made of pipe fittings to allow for raising and lowering the tower.
2. 4 holes (not shown) were eventually drilled in the base for hold-down stakes.



Image Notes

1. A ten foot length of conduit will serve as a tower. Both these pipes slide into the conduit.

Step 6: Paint all the wood parts

Next, I painted all the wooden parts with a couple of coats of white latex paint I had leftover from another project. I wanted to protect the wood from the weather. This photo also shows the lead counterweight I added to the left side of the 2X4 under the tail to balance the head.



Image Notes

1. Lead counterweight to balance the turbine.
2. Paint all the wood parts to protect them from the weather.

Step 7: The finished head of the wind turbine

This photo shows the finished head unit with the blades attached. Is that a thing of beauty or what? It almost looks like I know what I'm doing.

I never got a chance to properly test the unit before heading to Arizona. One windy day though, I did take the head outside and hold it high up in the air above my head into the wind just to see if the blades would spin it as well as I had hoped. Spin it they did. In a matter of a few seconds it spun up to a truly scary speed (no load on the generator), and I found myself holding onto a giant, spinning, whirlingig of death, with no idea how to put it down without getting myself chopped to bits. Fortunately, I did eventually manage to turn it out of the wind and slow it down to a non-lethal speed. I won't make that mistake again.



Step 8: Build the charge controller

Now that I had all the mechanical parts sorted out, it was time to turn toward the electronic end of the project. A wind power system consists of the wind turbine, one or more batteries to store power produced by the turbine, a blocking diode to prevent power from the batteries being wasted spinning the motor/generator, a secondary load to dump power from the turbine into when the batteries are fully charged, and a charge controller to run everything.

There are lots of controllers for solar and wind power systems. Anyplace that sells alternative energy stuff will have them. There are also always lots of them for sale on Ebay. I decided to try building my own though. So it was back to Googling for information on wind turbine charge controllers. I found a lot of information, including some complete schematics, which was quite nice, and made building my own unit very easy. I based my unit on the schematic of the one found on this web site:

<http://www.fieldlines.com/story/2004/9/20/0406/27488>

That web site goes into a lot of detail about the controller, so I'm only going to talk about it in fairly general terms here. Again, while I followed their general recipe, I did do some things differently. Being an avid electronics tinkerer from an early age, I have a huge stock of electronic components already on hand, so I had to buy very little to complete the controller. I substituted different components for some parts and reworked the circuit a little just so I could use parts I already had on hand. That way I had to buy almost nothing to build the controller. The only part I had to buy was the relay. I built my prototype charge controller by bolting all the pieces to a piece of plywood, as seen in the first photo below. I would rebuild it in a weatherproof enclosure later.

Whether you build your own, or buy one, you will need some sort of controller for your wind turbine. The general principal behind the controller is that it monitors the

<http://www.instructables.com/id/How-I-built-an-electricity-producing-wind-turbine/>

voltage of the battery(s) in your system and either sends power from the turbine into the batteries to recharge them, or dumps the power from the turbine into a secondary load if the batteries are fully charged (to prevent over-charging and destroying the batteries). The schematic and write-up on the above web page does a good job of explaining it. Much more information on building the charge controller, including larger and easier to read schematics, can be found on my web site at http://www.mdpub.com/Wind_Turbine/index.html

In operation, the wind turbine is connected to the controller. Lines then run from the controller to the battery. All loads are taken directly from the battery. If the battery voltage drops below 11.9 volts, the controller switches the turbine power to charging the battery. If the battery voltage rises to 14 volts, the controller switches to dumping the turbine power into the dummy load. There are trimpots to adjust the voltage levels at which the controller toggles back and forth between the two states. I chose 11.9V for the discharge point and 14V for the fully charged point based on advice from lots of different web sites on the subject of properly charging lead acid batteries. The sites all recommended slightly different voltages. I sort of averaged them and came up with my numbers. When the battery voltage is between 11.9V and 14.8V, the system can be switched between either charging or dumping. A pair of push buttons allow me to switch between states anytime, for testing purposes. Normally the system runs automatically. When charging the battery, the yellow LED is lit. When the battery is charged and power is being dumped to the dummy load, the green LED is lit. This gives me some minimal feedback on what is going on with the system. I also use my multimeter to measure both battery voltage, and turbine output voltage. I will probably eventually add either panel meters, or automotive-style voltage and charge/discharge meters to the system. I'll do that once I have it in some sort of enclosure.

I used my variable voltage bench power supply to simulate a battery in various states of charge and discharge to test and tune the controller. I could set the voltage of the power supply to 11.9V and set the trimpot for the low voltage trip point. Then I could crank the voltage up to 14V and set the trimpot for the high voltage trimpot. I had to get it set before I took it into the field because I'd have no way to tune it up there.

I have found out the hard way that it is important with this controller design to connect the battery first, then connect the wind turbine and/or solar panels. If you connect the wind turbine first, the wild voltage swings coming from the turbine won't be smoothed out by the load of the battery, the controller will behave erratically, the relay will click away wildly, and voltage spikes could destroy the ICs. So always connect to the battery(s) first, then connect the wind turbine. Also, make sure you disconnect the wind turbine first when taking the system apart. Disconnect the battery(s) last.

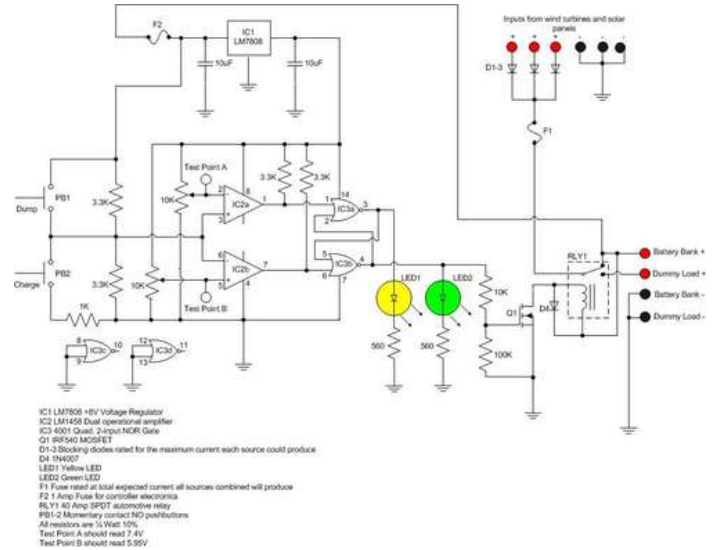
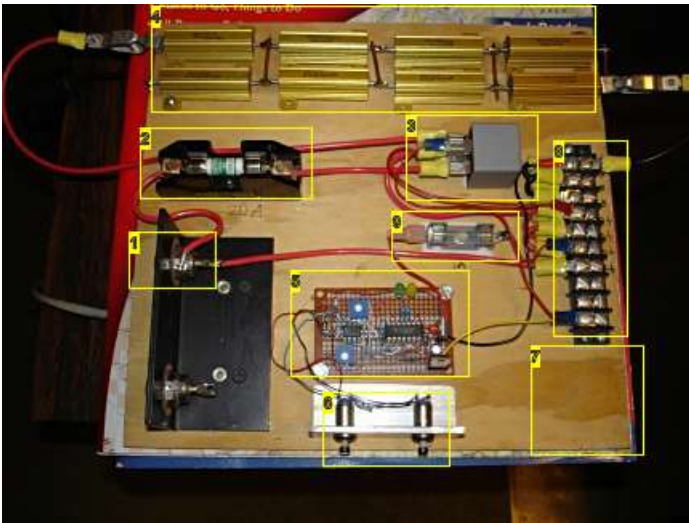

Image Notes

1. The blocking diode
2. The main fuse.
3. 40 Amp SPDT automotive relay.
4. Dummy load.
5. Controller electronics.
6. Charge and Dump buttons.
7. I built the prototype charge controller by bolting all the pieces onto a piece of plywood. Later I would rebuild it in a weatherproof enclosure.
8. Terminal block for connecting everything together, and for connections to the battery and wind turbine.
9. Fuse for controller electronics.

Step 9: Erect the tower

At last, all parts of the project were complete. It was all done only a week before my vacation arrived. That was cutting it close. I disassembled the turbine and carefully packed the parts and the tools I'd need to assemble it for their trip across the country. Then I once again I drove out to my remote property in Arizona for a week of off-grid relaxation, but this time with hopes of having some actual electricity on the site.

The first order of business was setting up and bracing the tower. After arriving at my property and unloading my van, I drove to the nearest Home Depot (about 60 miles one way) and bought the 10 foot long piece of 1 1/4 inch conduit I needed for the tower. Once I had it, assembly went quickly. I used nylon rope to anchor the pole to four big wooden stakes driven in the ground. Turnbuckles on the lower ends of each guy-line allowed me to plumb up the tower. By releasing the line from either stake in line with the hinge at the base, I could raise and lower the tower easily. Eventually the nylon line and wooden stakes will be replaced with steel stakes and steel cables. For testing though, this arrangement worked fine.

The second photo shows a closeup of how the guy-lines attach near the top of the tower. I used chain-link fence brackets as tie points for my guy-lines. The fence brackets don't quite clamp down tightly on the conduit which is smaller in diameter than the fence posts they are normally used with. So there is a steel hose clamp at either end of the stack of brackets to keep them in place.

The third photo shows the base of the tower, staked to the ground, and with the wire from the wind turbine exiting from the Tee below the conduit tower. I used an old orange extension cord with a broken plug to connect between the turbine and the controller. I simply cut both ends off and put on spade lugs. Threading the wire through the tower turned out to be easy. It was a cold morning and the cord was very stiff. I was able to just push it through the length of the conduit tower. on a warmer day I probably would have had to use a fishtape or string line to pull the cord through the conduit. I got lucky.

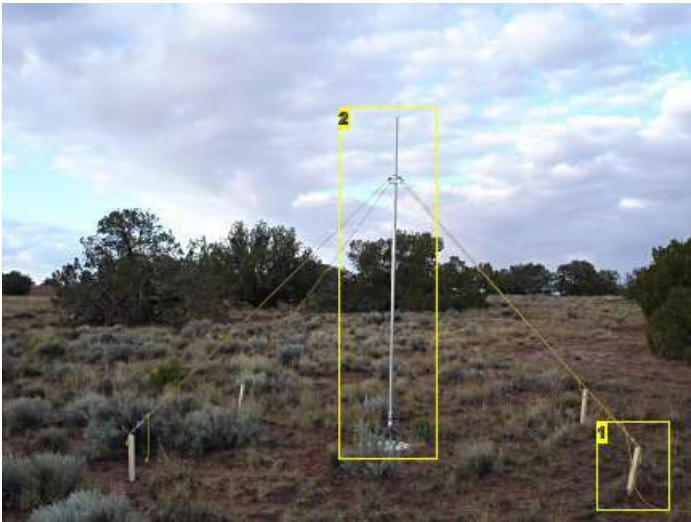

Image Notes

1. 4 wooden stakes to anchor the guy lines. Eventually will be replaced with steel stakes and steel cables.
2. 10 foot length if 1 1/4 inch conduit used as the tower for the wind turbine.

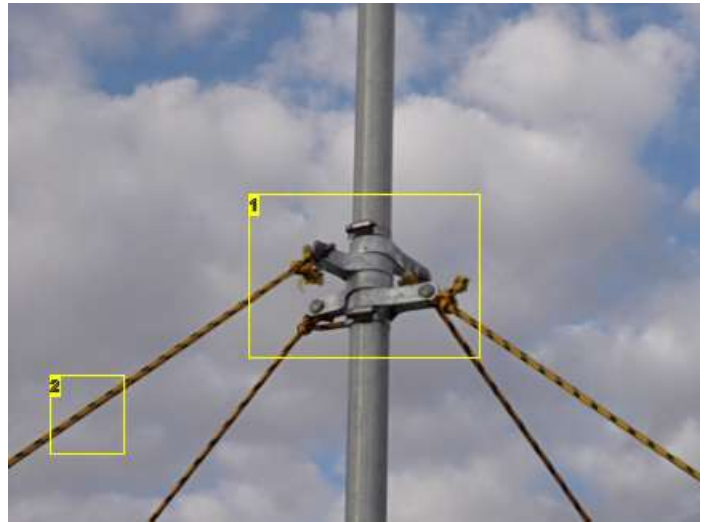

Image Notes

1. A stack of 4 chain link fence brackets used as anchor points for the guy wires. Steel hose clamps above and below the stack keep them in place.
2. Nylon rope used for guy wires. Will eventually be replaced with steel cables.

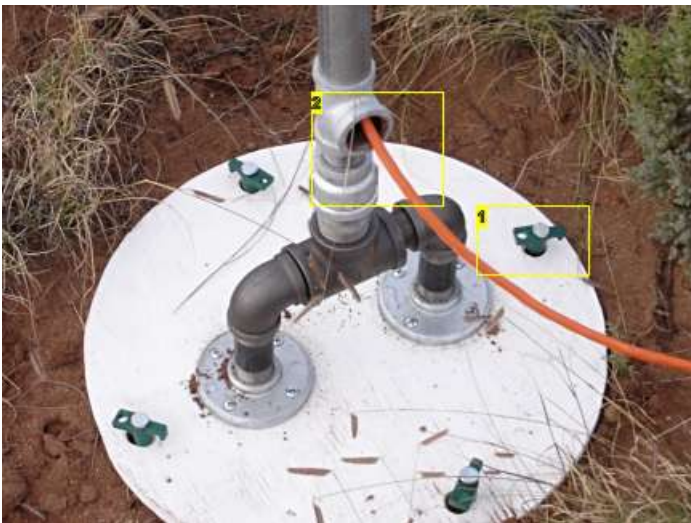

Image Notes

1. Stakes driven through holes in the base into the ground to stabilize the base.
2. The power cable from the wind turbine exits the bottom of the tower through a tee connector.

Step 10: Erect the wind turbine

The first photo shows the turbine head installed on top of the tower. I greased up the pipe on the bottom of the head and slid it into the top of the conduit. It made a great bearing, just as I'd planned. Sometimes I even amaze myself.

Too bad there was nobody around to get an Iwo Jima Flag Raising type picture of me raising the tower up with the head installed.

The second photo shows the wind turbine fully assembled. Now I'm just waiting for the wind to blow. Wouldn't you know it, it was dead calm that morning. It was the first calm day I had ever seen out there. The wind had always been blowing every other time I had been there. Well, nothing to do but wait.

Finally! The wind was up and the turbine was spinning, and the lovely electricity is starting to be produced.



Image Notes

1. Me.
2. My 40 acre parcel of remote Arizona property.
3. Tower hinged down for installation of the turbine head.



Step 11: Connect the electronics

The first photo below shows the electronics setup. The battery, inverter, meter and prototype charge controller are all sitting on a plywood board on top of a blue plastic tub. I plug a long extension cord into the inverter and run power back to my campsite. Lots more information of the electronics set-up can be found on my web site at http://www.mdpub.com/Wind_Turbine/

Once the wind starts blowing, the turbine head snaps around into it and begins spinning up. It spins up quickly until the output voltage exceeds the battery voltage plus the blocking diode drop (around 13.2 volts, depending on the state of the battery charge). It is really running without a load until that point. Once the that voltage is exceeded, the turbine suddenly has a load as it begins dumping power into the battery. Once under load, the RPMs only slightly increase as the wind speed increases. More wind means more current into the battery which means more load on the generator. So the system is pretty much self-governing. I saw no signs of over-reving. Of course in storm-force winds, all bets are off.

Switching the controller to dump power into the dummy load did a good job of braking the turbine and slowing it way down even in stronger gusts. Actually shorting the turbine output is an even better brake. It brings the turbine to a halt right now, even in strong winds. Shorting the output is how I made the turbine safe to raise and lower, so I wouldn't get sliced and diced by the spinning blades. Warning though, the whole head assembly can still swing around and crack you hard on the noggin if the wind changes direction while you are working on these things. So be careful out there.

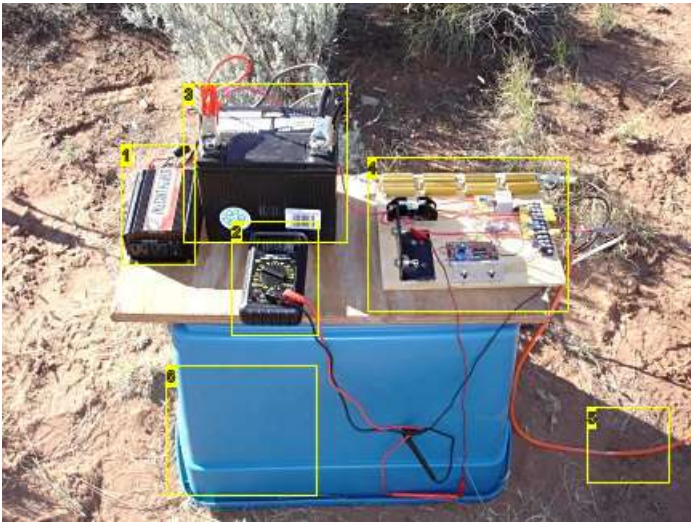

Image Notes

1. Inverter to provide 120V AC power. I plug an extension cord in here and run it back to my camp site to provide power.
2. Meter to monitor voltage and current.
3. 12V deep cycle lead-acid battery.
4. Prototype charge controller.
5. Cable to wind turbine
6. Blue plastic tub serving as a table for the electronics set-up. Later I would put everything inside the tub to protect it from the weather.



Image Notes

1. My meter shows the wind turbine producing 14.5 volts in a stiff wind.

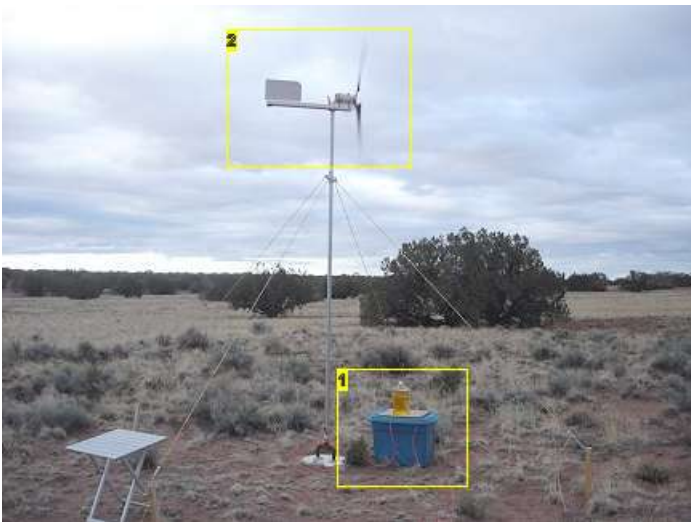

Image Notes

1. Electronics put inside a blue plastic tub to protect them from rain showers. The large jug of lamp oil on top keeps the wind from ripping the lid off.
2. The wind turbine just spinning away in a stiff wind from an approaching storm front.

Step 12: Enjoy having power in the middle of nowhere

How sweet it is! I have electricity! Here I have my laptop computer set up and plugged into the power provided by the inverter, which in turn is powered by the wind turbine. I normally only have about two hours of battery life on my laptop. So I don't get to use it much while I'm camping. It comes in handy though for downloading photos out of my camera when its memory card gets full, making notes on projects like this one, working on the next great American novel, or just watching DVD movies. Now I have no battery life problems, at least as long as the wind blows. Besides the laptop, I can also now recharge all my other battery powered equipment like my cell phone, my camera, my electric shaver, my air mattress pump, etc. Life used to get real primitive on previous camping trips when the batteries in all my electronic stuff ran down.

I used the wind turbine to power my new popup trailer on a later vacation. The strong spring winds kept the wind turbine spinning all day every day and most of the nights too while I was in Arizona. The turbine provided enough power for the interior 12V lighting and enough 120V AC at the power outlets to keep my battery charger, electric shaver, and mini vacuum cleaner (camping is messy) all charged up and running. My girlfriend complained about it not having enough power to run her blow-dryer though.



Image Notes

1. The wind turbine powers my laptop computer, battery charger, electric shaver, cell phone, air mattress pump, and lots of other things.
2. The first time I used the wind turbine I was tent camping alone on my property, and my power needs were modest.

Image Notes

1. On a later camping trip, my girlfriend and I stayed on the property in my pop-up camper. The wind turbine powered the lights and provided 120V AC at the outlets for light loads.

Step 13: How much did it cost?

So how much did all this cost to build? Well, I saved all the receipts for everything I bought related to this project.

Part	Origin	Cost
Motor/Generator	Ebay	\$26.00
Misc. pipe fittings	Homecenter Store	\$41.49
Pipe for blades	Homecenter Store	\$12.84
Misc hardware	Homecenter Store	\$8.00
Conduit	Homecenter Store	\$19.95
Wood & Aluminum	Scrap Pile	\$0.00
Power Cable	Old extension cord	\$0.00
Rope & Turnbuckles	Homecenter Store	\$18.47
Electronic Parts	Already on hand	\$0.00
Relay	Auto Parts Store	\$13.87
Battery	Borrowed from my UPS	\$0.00
Inverter	Already on hand	\$0.00
Paint	Already on hand	\$0.00
Total		\$140.62

Not too bad. I doubt I could buy a commercially made turbine with a comparable power output, plus a commercially made charge controller, plus a commercially made tower for less than \$750-\$1000.

More details on this project and my other alternative energy projects including my home-built solar panels, and my home-built biomass gasifier can be found on my web site.



Step 14: Update

I have completed the rebuild of the charge controller. It is now in a semi-weatherproof enclosure and I have also added a built in voltage meter. Both were bought cheap on Ebay. I have also added a few new features. The unit now has provisions for power inputs from multiple sources. It also has built-in fused 12V power distribution for three external loads.

The second photo shows the inside of the charge controller. I basically just transferred everything that I originally had bolted onto the plywood board in the prototype into this box. I added an automotive illuminated voltage gage and fuses for 3 external 12V loads. I used heavy gage wire to try to reduce losses due to wire resistance. Every watt counts when you are living off-grid.

The third image is the schematic for the new charge controller. It is pretty much the same as the old one above, except for the addition of the Volt meter and extra fuse blocks for the external loads. A larger, easier to read version of the schematic, and more information on the new charge controller can be found on my web site at http://www.mdpub.com/Wind_Turbine/

The fourth photo is a block diagram of the whole power system. Note that I only have one solar panel built right now. I just haven't had the time to complete the second one. Please visit my home-built solar panel page at <http://www.mdpub.com/SolarPanel/> for more information on home-built solar panels.

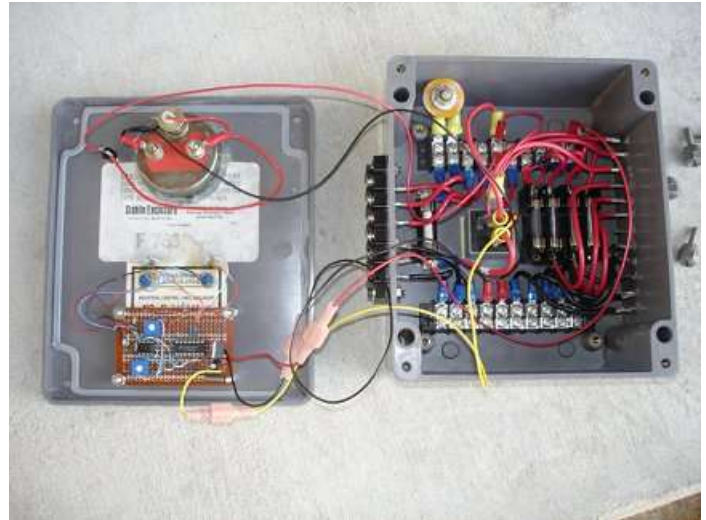
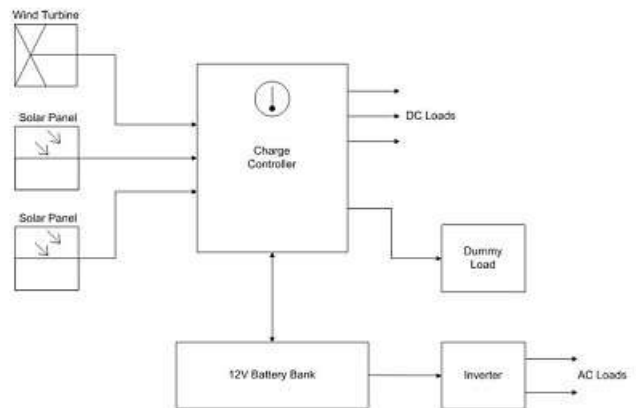
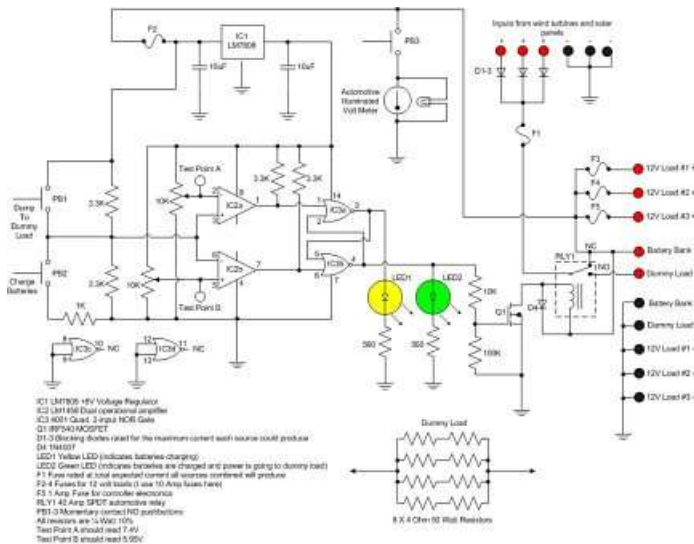

Image Notes

1. The new charge controller built into a weatherproof box.



Step 15: Update 2

Once again I stayed on my remote property during my recent vacation in Arizona. This time I had both my home-built wind turbine and my home-built solar panel with me. Working together, they provided plenty of power for my (admittedly minimal) electricity needs.

The second photo shows the the new charge controller unit. The wires on the left side are coming from the wind turbine and solar panel. The wires on the right side are going to the battery bank and dummy load. I cut up an old heavy-duty 100 ft. extension cord to make cables to connect wind turbine and solar panel to the charge controller. The cable to the wind turbine is about 75 feet long and the cable to the solar panel is about 25 feet long. The battery bank I am currently using consists of 11 sealed lead-acid 12V batteries of 8 Amp-Hour capacity connected in parallel. That gives me 88 Amp-Hours of storage capacity, which is plenty for camping. As long as it is sunny and windy, (nearly every day is sunny and windy on my property), the wind turbine and solar panel keep the batteries well charged.

More details on this project and my other alternative energy projects including my home-built solar panels, and my home-built biomass gasifier can be found on my web site.

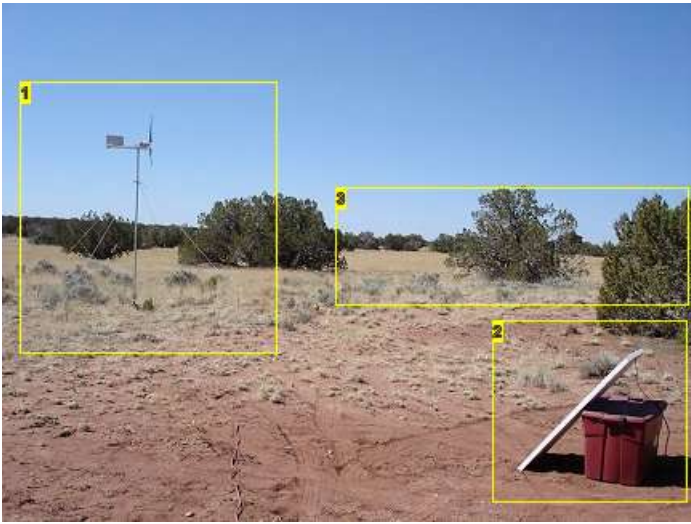

Image Notes

1. Wind turbine.
2. Solar panel.
3. My 40 acre parcel of remote Arizona property.

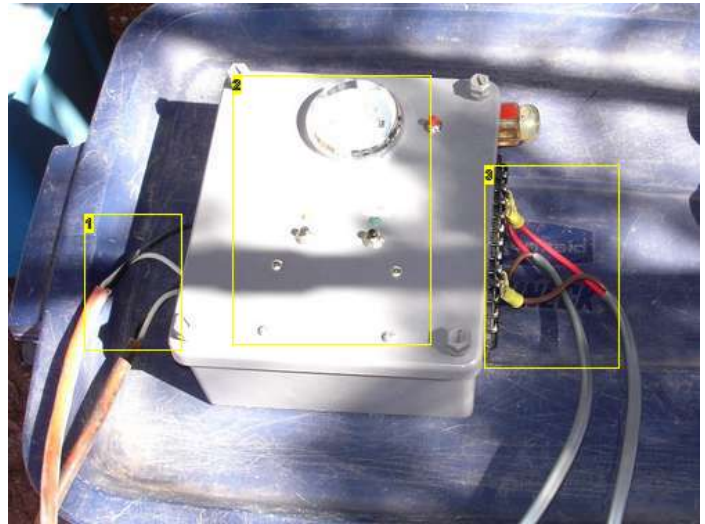

Image Notes

1. Cables bringing power from the wind turbine and solar panel.
2. The new charge controller unit in its weatherproof box.
3. Cables carrying power to the battery bank and dummy load.

Related Instructables



DIY 1000 watt wind turbine by sspence



A Paper Plate and Pop Bottle Savonius Wind Turbine by egbertfitzwilly



VAWT Lenz type. Stage 1. Converting wind power to rotary motion. by Dr Qui



4" vawt, savonius, vertical axis, wind turbine, ametek by faroun



Faroun Lenz v2 Vertical Axis Wind Turbine by faroun



V8 vawt, savonius, vertical axis, wind turbine, by faroun

Comments

50 comments

[Add Comment](#)

[view all 260 comments](#)

 **jlund** says: Mar 13, 2011. 9:50 PM [REPLY](#)
 K so I'm just a kid with out a 1,000,000,000,000 dollars and what to run an old fan motor as a wind turbine attached to my roof with power cables coming through my window to power my clock and charg my iPad I have it drawn out in my head I just need some help of how I get it rotating and producing power I have no clue how to set this up to make power plz help

 **ryandean98** says: Mar 17, 2011. 8:47 PM [REPLY](#)
 You really can't use a fan motor because it has no magnets in it.

 **ryandean98** says: Mar 17, 2011. 8:16 PM [REPLY](#)
 What happens to the dumped power???

 **austinpowerzzzzz** says: Feb 26, 2011. 12:00 PM [REPLY](#)
 im planning on building a tree house. and i think htis would be perfect for suplieing electricity for it. is there any way i could convert the electricity coming from he turbine into an electric outlet? if anyone ould hlep that would be sweet.

 **zezoo22** says: Jan 5, 2011. 4:31 AM [REPLY](#)
 i»™j»@i»cej».i»•j»- j»°j»@i» « i»Ži»Ši»•j»- i»•j»•j»•j» i»°Ži»°i»»•j»•j»Ši»•

 **Ninja1507** says: Jan 4, 2011. 1:26 PM [REPLY](#)
How much (About) would a 24v (DC) Electric Scooter motor produce? I don't have the scooter anymore cause the battery went out, however I kept the motor.

 **madmaxismartin** says: Dec 2, 2010. 10:59 PM [REPLY](#)
All good and well, I really like the step by step easy instructions, there is though just one thing bothering me, I know the power cable coming from the generator motor goes down the pipe and out again, dont you think there will be a chance that the turbine goes round and round and round till the cable gets tangled inside the pipe, or did you have something in place to prevent this?
Kind regards
Martin

 **dairyfarmer777** says: Dec 5, 2010. 2:09 AM [REPLY](#)
He said his doesn't get tangled because the wind blows from west and south consistently (1/4 of a circle) , and if it does he could just manually untwist it. Although in the future he said he may install slip ring connections, if you think your cord will twist you can try using slip rings.

 **jomac_uk** says: Dec 25, 2010. 4:52 PM [REPLY](#)
I have read on many sites that show the construction of small generators like this, most of them just have the cable coming straight down from the generator, either on the inside of the pole, or the outside. By the law of averages, any twists in the cable, around the pole tends to untwist over a period of time. Certainly on my small mill that i had running for about 18 months, i only had to untwist the cable from around the pole about 3 times, and this was only because it annoyed me, rather then necessity.
I put a weatherproof plug and socket at the bottom of the pole to allow this.

 **ARJOON** says: Dec 3, 2010. 11:54 AM [REPLY](#)
read instructable well

 **mabyu** says: Jul 20, 2010. 4:22 PM [REPLY](#)
how many watts would this motor produce with steady 60mile winds http://www.amazon.com/Dayton-3KW43-Motor-10-Phase/dp/B001QRXCS/ref=sr_1_11?ie=UTF8&s=industrial&qid=1279667661&sr=8-11

 **dairyfarmer777** says: Dec 5, 2010. 2:19 AM [REPLY](#)
probably would depend on the angle of attack of the blades, depending on the rpms of them

 **vernors** says: Dec 3, 2010. 9:15 AM [REPLY](#)
does it matter if its an AC or DC genorator?

 **dairyfarmer777** says: Dec 5, 2010. 2:16 AM [REPLY](#)
You'd probably want a dc generator because that will provide constant voltage rather than an alternating one.

 **altenburgpj** says: Jun 7, 2010. 7:53 AM [REPLY](#)
I looked at the website you suggested for the Ametek motor specifications and the chart on page <http://www.tlgwindpower.com/Ametek99data.htm> shows: Ametek 99VDC 010300F6 rpm's Open Volts Shorted Amps Breaks 1 kW 950 35.5V 29.3 Amps 1.1 kW 1000 37.2 30.8 Amps 1.2 kW 1050 39.0 31.2 Amps But that is not 1kW of actual output. Since power is voltage x amperage, and the chart clearly states the current is produced when the output is shorted, then the output voltage is zero or very close to zero. With one foot of 12AWG wire (.00187 ohms per foot) you would have a voltage drop on the wire of .055 volts (29.3 Amps x .00187 ohms). Power output would be 1.605 Watts ($P=E * I$) (.055 Volts * 29.3 Amps). That is watts, barely enough to light a bulb. Of course in real life we would never short the output of our generator, but the information in this chart can not be relied upon to build a 1kW generator. Something smaller certainly. Do you have data in voltage and current to establish the actual output of your generator?

 **dairyfarmer777** says: Dec 5, 2010. 2:02 AM [REPLY](#)
He says on his site he got 14.5v "in a stiff wind."
"The turbine provided enough power for the interior 12V lighting and enough 120V AC at the power outlets to keep my battery charger, electric shaver, and mini vacuum cleaner " not enough for a hairdryer though he said.

 **ARJOON** says: Dec 3, 2010. 12:54 PM [REPLY](#)
this is the power loss. not the power output

 **-max-** says: Jul 18, 2010. 4:47 PM [REPLY](#)
what about water resistance?



ARJOON says:
null

Dec 3, 2010. 12:12 PM [REPLY](#)



greatscotmagic says:

Would the blades from an electric fan work for the turbine? Could I reverse engineer an electric fan into a small wind turbine? Thanks.

Aug 16, 2009. 11:43 AM [REPLY](#)



ARJOON says:

yes you can use blade of fans, there must be only 3 of them, the new kind in orange. you can't use the motor from the fan as a generator unless you put some magnets in it

Dec 3, 2010. 12:11 PM [REPLY](#)



juanvi says:

I dont really know about aeronautics involve, I study mechanics engineering, and I love planes since I'm 3 years old. When I was little I realized that the blades used in boats are not the same as the blades used in planes. the blades of an electric fan are "boat type" blades, and I think they are designed to move a large quantity of air (large area). On the other hand, thin blades move less air, so they oppose less force to the engine (turbine, motor, whatever that makes them spin). I think its in a sense like the relation between small and big gears, and their velocity/force relation. So, "boat" blades need lots of air to move, while thin ones need less air. If you want the air to move the turbine, use thin ones, as the planes. If your turbine is small, there was somewhere in the internet a tutorial for doing your own blades, depending on the angle of attack you want them to have and all of that..

Sep 1, 2009. 3:40 PM [REPLY](#)



Fredggp says:

It's not interesting to use "Boat type" blades (as you write) in wind turbine. Why? Because the area occupied by the blades becomes an obstacle to the wind. If the speed of the wind is V_1 (around the area), the speed of the wind before the blades is a value that is a little bit smaller V_2 (where $V_1 > V_2$). Same occurs with the speed after blades, decreases a little more. When you need more force to pump water for example, you can use more blades because each blade contributes with the total force in motor shaft. This is the difference between the farm wind mills and power plants wind turbines.

Dec 2, 2010. 9:26 AM [REPLY](#)



vernors says:

i want to connect this to my house. do i still need the batteries? or is there a simpler way to hook it up. and how would i hook it up?

Dec 3, 2010. 9:13 AM [REPLY](#)



ARJOON says:

no you should charge batteries. then buy an inverter depending of you power usage. never connect it in parallel with mains electricity unless if mentioned that it can synchronize. if you hook it directly to your inverter without passing through batteries the following will occur:

Dec 3, 2010. 11:41 AM [REPLY](#)

1. Uneven wind give uneven power. therefore sometimes low performance off appliances.
2. This wind turbine gives to low power for direct use.
- 3, uneven voltage will ruin the inverter.

i suggest you that you charge batteries then use the stored power



ARJOON says:

is this your project or did you copy it from another site

Dec 3, 2010. 11:37 AM [REPLY](#)



mabyu says:

how to read the watts your getting from a generator. all the multimeters I see are just volts and amps and I cant figure out how to read them, isn't there just a watt meter that's not for wall sockets?

Jul 2, 2010. 6:57 PM [REPLY](#)



Derin says:

measure both volts and amps then multiply volts by amps to get watts

Jul 5, 2010. 2:26 AM [REPLY](#)



bingo1912 says:

Here is the way to calculate and a chart as well. Once you learn how to use it it will help you solve any problem you have.

<http://www.the12volt.com/ohm/ohmslaw.asp>

:)

Gary

Dec 2, 2010. 8:49 PM [REPLY](#)



Andruha1123 says:

why would u dump electricity? just connect a bulb and have a light or something.

Jan 2, 2009. 11:40 PM [REPLY](#)



aplavins says:

over charging batteries ruins them, although there could be a better use for the excess.

Aug 18, 2009. 5:17 PM [REPLY](#)



tristantech says:
 Couldn't you just add more batteries instead of throwing the rest away?

Apr 4, 2010. 8:35 AM [REPLY](#)



bingo1912 says:
 Yes you can add more batteries

Dec 2, 2010. 8:46 PM [REPLY](#)



Dr_Stupid says:
 You kids never took Calculus, did you?

Apr 4, 2010. 10:05 AM [REPLY](#)

Let me break it down for you in simple terms...

if battery X takes 10 hours to charge fully
 and turbine Y runs non-stop for generously...250 out of 365 days out of the year.

That's 5090 hours worth of electricity that one has to use. (to put it in simple terms, it's much more complicated than that...but you get the idea.)

I don't know about you....but I can't afford 509 batteries. Can you?

That being said, the smart thing to do would be to run it thru a sinewave transformer and sell it back to the powercompany, but not everyone is set up to do that. Ergo, you have to do something with the excess electricity that would otherwise burn up your batteries....the only other option is to use it, either in the form of actual appliance usage, or change it to another form of energy that is easily "wasted"....the easiest is of course, heat.

Light is another alternative, but nobody said you couldn't use a hot-water heater as a dummy load. (think outside the box, a lil')



gdelisle says:
 Yes, but recall the application. This site is way, way off the grid and selling it back to the power company would not be an option. Also, the whole reason he's out there is because of the darkness, so channeling extra power into lights is not a good use of it. But a heater might be a welcome addition on those cold Arizona winter nights.

May 17, 2010. 9:34 AM [REPLY](#)



unclep says:
 Not to mention heating the water to possibly use in a small greenhouse. Recirculate the warmer water through the growing beds and he has a nice source of food during those cold months as well.

Feb 6, 2011. 4:04 AM [REPLY](#)



mac11irl says:
 Im currently building my first turbine. Its only small, using as 30Watt motor from an old washing machine. i have also used some drain pipe for my blades, and housed the the unit snugly inside inside plastic piping. I have a major aerodynamic problem tho... everytime the wind blows, my turbine rotates so that it is faced out of the wind! i have attached 3 tail fins, and tried turning the blades around, but nothing seems to work! when i hold it into the wind, it will spin wonderfully, giving out about 15volts, but when left to its own it turns out. Any advice??? please ? btw, love your set up in this instructable!!

Sep 1, 2009. 2:30 PM [REPLY](#)



truesprocket says:
 motor to far out , tail to close to pivot point , pivot loose & tilts heavy end down when the wind blows, you'r balance is off.

Dec 2, 2010. 8:51 AM [REPLY](#)



bingo1912 says:
 The Tail needs to be four times as long from the pivot point, as the front where the blade is to make sure that it keeps the blades into the wind. Flip it end for end and try it. If that doesn't work keep increasing.

Dec 2, 2010. 8:45 PM [REPLY](#)



juanvi says:
 maybe the problem is that the part that holds the turbine with the tail is too small. Or maybe that the tail fins are small, look at the one used in this instructable, its pretty big, considering the size of the whole thing. I don't really know, but i'll think about it

Sep 1, 2009. 3:22 PM [REPLY](#)



The Lightning Stalker says:
 Q1 should be substituted with a 2N7000. An IRF540 is total overkill for switching a relay coil. The IRF540 is powerful enough that it might be used *instead* of a relay. Check the milliamp draw of the relay coil and use an appropriate transistor. You could save like \$5 that way.

Dec 2, 2010. 6:43 PM [REPLY](#)



tubajoey1 says:
 about how long did it take you to complete this step? i am going to try to make a wind turbine, based on your instructions, and hopefully be able to run everything in my room. thanks

Sep 24, 2008. 1:38 PM [REPLY](#)



mdavis19 says:
 It took about a month of my spare time to build it.

Sep 27, 2008. 6:20 AM [REPLY](#)



mabufo says:

Dec 2, 2010. 11:15 AM [REPLY](#)

Do you know of any controllers that I could purchase that would work with this turbine design? I don't know anything about electronics, nor do I have the tools for the job if I decided to attempt building my own.

How expensive do they run?



jharuni says:

Dec 2, 2010. 10:54 AM [REPLY](#)

Very nicely written article. Thank you.

Are there stops preventing the head from turning too far out of the prevailing wind direction? Or is it free to turn infinitely in either direction? If so, how did you run the wires from the head to the tower so that they won't twist up?



robb91 says:

Dec 22, 2009. 11:57 PM [REPLY](#)

can we use a 12 volt DC motor



Fredggp says:

Dec 2, 2010. 9:02 AM [REPLY](#)

Yes, you can. Any DC motor can be used like a generator.



grabbit says:

Oct 16, 2010. 7:49 PM [REPLY](#)

nice project and excellent explanation complimented with both photos and video. thanks!



profpat says:

Sep 4, 2010. 8:57 PM [REPLY](#)

great idea! very good project!



wgreenfield says:

Jul 23, 2010. 12:42 AM [REPLY](#)

Good day. Could you tell me if a small motor from an electric hairdryer would work. thank you in advance.

[view all 260 comments](#)