

# **C-3PO ROBOT WALKING MECHANISM (CORNELL CUP USA, PRESENTED BY INTEL 2013-2014)**

Master of Engineering Design Report

May 15, 2014

Lijia Wang and Stephanie Altrui

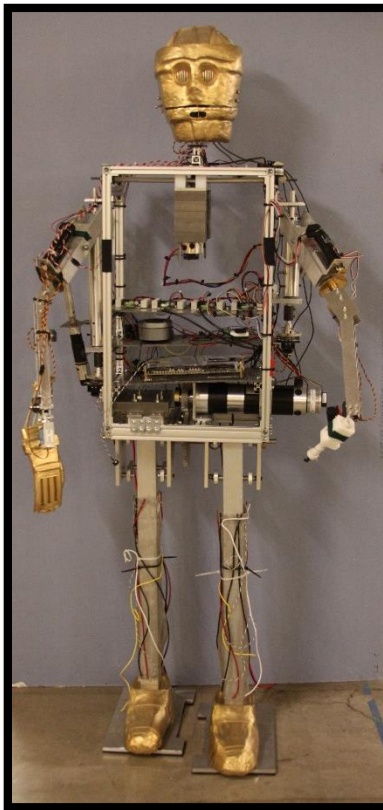

# Table of Contents

1	Abstract.....	4
2	Design Criteria .....	4
2.1	Introduction .....	4
2.2	Use Case Determination.....	5
2.3	Performance Criteria Determination .....	6
3	Inspiration from Existing Humanoid Robots .....	7
3.1	Introduction .....	7
3.2	Research on Existing Robots with 6 DOF Legs .....	8
3.3	Initial Concepts .....	11
3.3.1	Pivot and Locking Turning Mechanism .....	12
3.3.2	Wheel Turning Mechanism.....	12
3.3.3	Heely Turning Mechanism .....	13
3.3.4	Tank Tread Turning Mechanism.....	13
3.3.5	Cam Shaft/Baby Doll Turning Mechanism .....	14
4	Decision Matrices .....	14
4.1	Walking Degrees of Freedom .....	14
4.2	Turning Mechanisms .....	16
4.3	Joint Speed Requirements.....	18
4.3.1	Motivation .....	18
4.3.2	Measuring Hip Angular Speed.....	19
4.3.3	Calculations.....	19
4.3.4	Conclusions .....	22
5	Design Shift: 12DOF to 1DOF.....	22
6	Final Design: Four-Bar Linkage Mechanism, 1 DOF .....	22
6.1	Design Overview .....	22
6.2	Weight-Shifting Mechanism .....	24
6.3	Finite Element Analysis of the Ankles .....	25
6.4	Leg to Torso Integration .....	27
6.5	Manufacturing: Major Components .....	29
7	Motor Selection .....	31

7.1	The Physical Setup .....	32
7.2	Free Body Diagram.....	33
7.3	Motor Torque Requirement Calculations.....	33
7.4	RPM Requirement Calculations .....	34
7.5	Basic Spec Summary.....	34
7.6	Final Decision .....	34
8	Bill of Materials.....	34
9	Testing.....	38
10	Results and Conclusions .....	41
11	Appendix .....	42
11.1	Motor Specifications .....	42
11.2	Citations.....	44

# 1 Abstract

The Cornell Cup USA Creation Team is comprised of 50 multidisciplinary engineering students. The goal of the team for 2013-2014 was to develop Star Wars inspired robots to be showcased at Walt Disney World. Two robots were designed and built: a humanoid walking robot and an autonomous mobile robot, based on C-3PO and R2-D2 respectively.

One of the main functions of the humanoid robot was to walk in a straight line. The challenge presented was to design, manufacture, and demonstrate the walking capability in less than a year's time. Many existing humanoid walking robots have six degrees of freedom per leg. However, Cornell Cup's design was simpler due to time and budget constraints. The design utilized a four-bar linkage mechanism with a single degree of freedom. The mechanism was capable of actuating the robot's legs to create a straight-line walking motion. The main advantage of this system was that it was powered by a single DC gearmotor, thus drastically simplifying the control system.

The completed robot stood over 6 feet tall and weighed 125 pounds. It was capable of walking at 6 inches per second on flat ground. The robot was successfully demonstrated at Walt Disney World on May 1-3, 2014.

## 2 Design Criteria

### 2.1 Introduction

The walking mechanism is one of three subsystems of C-3PO. The other two are the arm, including shoulder and elbow motion, and torso design, including balancing mechanisms. The first step was to create a comprehensive timeline with tasks and subtasks, deliverables and major deadlines. Each sub-group was designated as a milestone and the following is a list of tasks within the walking mechanism milestone.

1. Define Use Cases
2. Define Performance Criteria
3. Research Walking Mechanisms
4. Estimate Scale
5. Design
6. Material Selection
7. Integrate with ECE components
8. Integrate with rest of body
9. Prepare for Assembly
10. Assemble
11. Test Walking Mechanism
12. Iterate

## 2.2 Use Case Determination

The main use case for the walking mechanism is that the system needs to translate forward, preferably with a bipedal human walking motion. However, this use case quickly breaks down into many sub-problems which include making C-3PO stand, balance, and stop. In addition, beyond the system functioning, the system must be able to be disassembled and reassembled quickly and efficiently for the competition.

Possible misuses were also considered. Events such as control of the system is lost, the motors shutting down mid-step, and the system stepping on an unexpected object were all considered. Later in the design process, solutions of a kill switch and a mechanism such as a kill switch must be incorporated into the design. Similarly, if the system ceases to work mid-step, the walking mechanism must incorporate a method for the system to safely stop and remain balanced. At the very least, it must be able to balance itself until a team member is able to attend to the problem. Another consideration is mechanical specifications. For example, the specifications of the motors need to be over compensated for in order to allow for misuses, such as the system accidentally being pushed, or too much weight being put onto the system.

Following is a list of use cases determined:

- User commands C-3PO to walk forward
- User commands C-3PO to walk backward
- User commands C-3PO to turn
- User commands C-3PO to walk up/down stairs
- User commands C-3PO to walk up/down ramp
- User sets C-3PO upright
- User replaces damaged components
- User commands C-3PO to stop walking
- User disassembles C-3PO for packaging
- User reassembles C-3PO

Following is a list of potential misuses determined:

- User trips C-3PO
- User pushes C-3PO
- User drives C-3PO into an obstacle
- User drives C-3PO off stage

The “unnecessary” use cases remained on the list for possible pursuit if time allowed. However, they were given less weight in the design. The use case determination process goes hand in hand with that of the timeline creation. An iteration step exists in the timeline allowing for members to return to the timeline after defining use cases and re-format the timeline as is necessary. For example, an additional use case of the user commanding C-3PO to ride a Segway had initially been considered. If this consideration had been pursued, tasks such as finding

Segway vendors, purchasing the product, and incorporating a leaning mechanism would have been inserted into the timeline.

This further solidifies the importance of determining use cases – processes that initially weren't considered may prove to be integral to the realization of the overall system and help with the overall planning of the project, being sure to fulfill every functional requirement of the system. In addition, these use cases are an overall insight to what the system will be able to offer. This is especially important on this team, which is split into three main sub-teams – Mechanical, Electrical, and Computer, and split even further which each sub-team.

### 2.3 Performance Criteria Determination

After determining the use cases, the next set of decisions that need to be made is the quantifiable specification of the qualitative use cases. For example, C-3PO is to be able to move forward, the speed at which the task is performed must be specified. This step quantifies the goals and provides an initial rubric with which to judge each of the concepts which will be brainstormed.

Performance Metric	Target Value
Walking Speed	1 to 3 ft/s
Vertical terrain traversal ability	6 inches
Stride Length	1 ft
Life of Motors/Batteries specific to walking mechanism	TBD
Power consumption of motors/batteries	TBD
Maximum allowable load on legs	150 lbs
Machinability	Limited to 3 axis CNC
Noise Level	60 dB
Height (total)	5'9"
Leg Length	34.5"
Weight of Legs	50 lbs
Ability to maintain traction (ability to walk on different surfaces)	Slips less than 0.5 inches/stride
Incline Traversal	Able to traverse and incline of 15 degrees
Ease of assembly (including ability of ECEs to get inside to wire) and disassembly	Max time of 3 hours
Ease of interfacing with torso	Max time of 1 hour
Ease of modifying/switching out parts if a component breaks	No permanent fastening mechanisms

**Table 1: Performance Criteria Determinations**

A qualitative performance metric was also added – aesthetic value, which was given the least weight among all the metrics.

After this, an ideal set of DOFs and requirements were determined which would allow the above performance criteria.

Joint	DOF	Range of Motion at Each Joint (max)
Hip	3	Roll: (+/-) 45 degrees
		Pitch: (+)60 degrees (-)30 degrees
		Yaw: (+) 30 degrees
Knee	1	(+) 30 degrees
Ankle	2	Pitch: (+/-) 20 degrees
		Yaw (+/-) 15 degrees

**Table 2: Degree of Freedom Determination**

### 3 Inspiration from Existing Humanoid Robots

#### 3.1 Introduction

Walking humanoids is a research field that has been highly explored. Much of the initial brainstorming process for this system’s walking mechanism comes from researching these pre-existing models, while also keeping in mind that the relatively restricted budget and time that was available.

Robotic walking mechanisms can be divided into two main categories: static and dynamic. They can be thought of as walking while standing and walking while falling respectively.

A robot that implements static walking is always balanced; that is, the projection of its center of gravity onto the ground is always within its ground contact area. Due to this fact, such a robot is much easier to control compared to its dynamic walking counterpart. This walking technique has been successfully used in many robots today. However, the movement of static walking is not true humanoid walking. It is not as adept at traversing uneven terrain as dynamic walking. In addition, it is not very power-efficient, since active power is required to actuate every joint movement.

A robot that implements dynamic walking is not always in balance. Such a robot is continually falling and bracing itself as it walks. As a result, it draws power from gravity to actuate its forward movement, and is therefore more power-efficient than robots that use static walking. In addition, the gait of a dynamic walking robot is similar to that of an actual human, which grants it better capabilities in traversing uneven terrain. The main drawback to dynamic walking is that since the robot is not always in balance, it requires a complicated and robust feedback control system. Such a control system is extremely difficult to implement by university level students.

Cornell professor Andy Ruina, an expert in the field of humanoid walking robotics, has been consulted regarding this project. Professor Ruina's research in the past three decades has been focused on dynamic walking. His lab has made significant progress. However, after consulting Professor Ruina and performing some basic research (explained in the two paragraphs above), it was concluded that due to the time and budget constraints of Cornell Cup, it is too ambitious to pursue dynamic walking. Instead, static walking was determined to be more feasible.

### **3.2 Research on Existing Robots with 6 DOF Legs**

Research conducted by team members had shown that most existing humanoid walking robots implement six degrees of freedom (DOF) in each leg: three at the hip, one at the knee, and two at the ankle. These degrees of freedom are required for walking, turning, and keeping the torso upright. Thus the initial design goal for C-3PO was to create a 12 DOF (6 DOF per leg) walking mechanism. Four existing 12 DOF robots were studied for design inspiration. These robots include: Honda E1, Honda ASIMO, Aldebaran NAO, and RoboCup adult size humanoid league robots.

The E1 (Figure 1) was developed by Honda in 1987. It was among a series of experimental robots (E-series) created by Honda in order to research and develop humanoid walking mechanisms. In addition to being the first robot in the E-series to implement 12 DOF, E1 used static walking (robots after E1 used dynamic walking), which fit the initial design goals for C-3PO. E1 took each step by putting one leg in front of the other. It remained balanced by constantly keeping its center of gravity on top of the foot planted on the ground. E1 stood at 4 feet 2.7 inches tall (the legs were just over 2.5 feet long) and weighed 159 pounds. It was similar in size to the design goal for C-3PO. However, E1 could only walk at 0.25 km/h or 2.7 in/sec; this was quite slow compared to normal human walking. Overall, because the Honda E1 had many similarities to the design goals of C-3PO, it was a useful example to study.



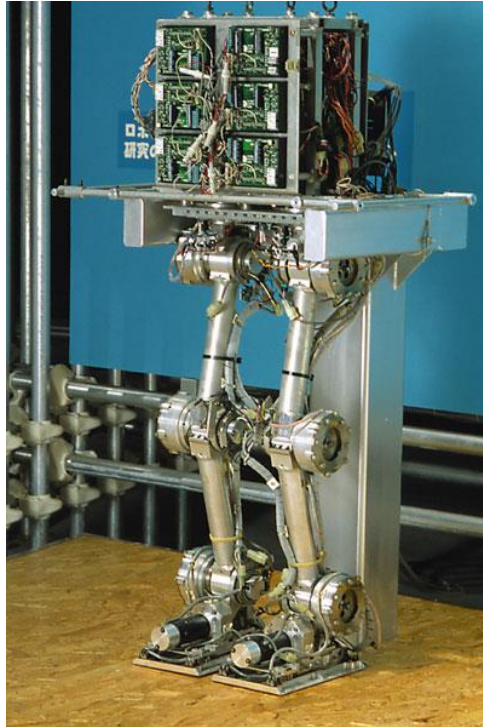

**Figure 1: Honda E1**

Developed in the 2000s, the Honda ASIMO (Figure 2) was a distant successor to the E-series. It stood 4 feet 3 inches tall and weighed 106 pounds. Like the E1, ASIMO also used 12 DOF for its legs, but it was able to achieve a human-like walking motion (dynamic). In addition, it was even able to run at 6 km/h or 5.5 ft/sec. However, since ASIMO used dynamic walking, it was too advanced for the C-3PO design, so it was used only for reference in the design process.

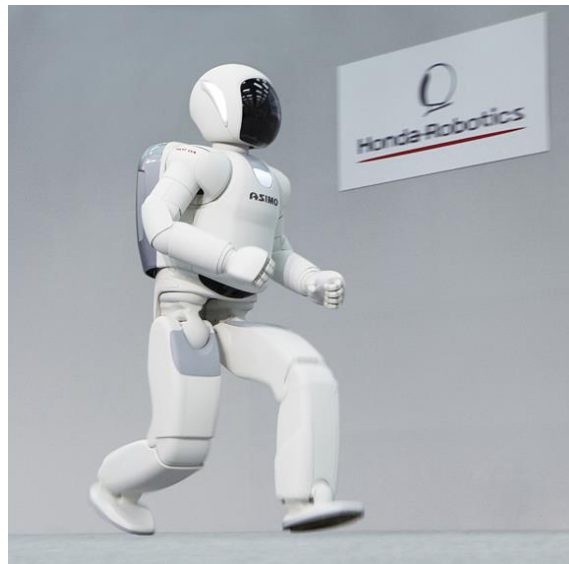

**Figure 2: Honda ASIMO**

The Aldebaran NAO (Figure 3) was first released in 2008 and is currently used in the RoboCup standard platform league. Developed by Aldebaran Robotics, NAO was a small, programmable, autonomous, humanoid robot meant for research and education. In fact, the Autonomous Systems Lab at Cornell used them for research. NAO was 22.5 inches tall and weighed 11.4 pounds, small and light enough to be hand-held. Despite its small size compared to C-3PO, it was studied due to its ability to walk and balance in a pseudo-static manner, which was the ultimate goal for C-3PO. NAO walked in a similar fashion to Honda E1, but it was much faster and more fluid. In addition, it was quite useful that NAO could pick itself up when it fell over, which was a potentially desired functionality for C-3PO.



**Figure 3: Aldebaran NAO**

The RoboCup adult size humanoid league robots had walking mechanisms that were the most similar to what was desired for C-3PO. These robots were designed and built by other college students, and so they were of a similar technical level to what C-3PO could achieve. In general, these robots were around 5 feet tall, similar to C-3PO. However, they were light enough to be picked up by a single human while C-3PO was planned to be much heavier. These robots walked in a motion similar to the NAO. In addition, some of them were able to sidestep. The initial 6 DOF concept design for the C-3PO leg was based heavily on these RoboCup robots. A particularly good example was the 2013 runner-up: Team Taiwan (Figure 4), which exhibited very fluid and stable motion. The leg joints of these robots were studied in an attempt to identify ways that they can be implemented on C-3PO.

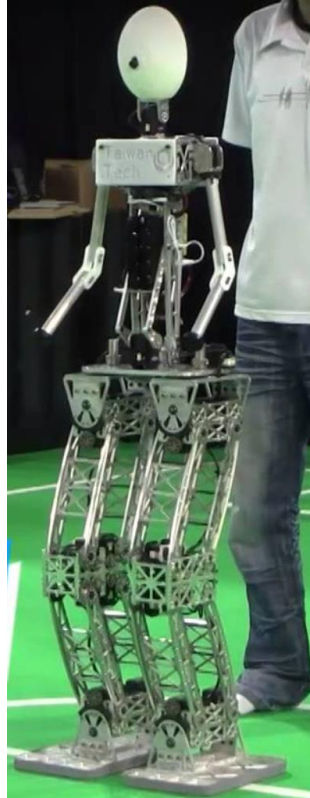

**Figure 4: 2013 RoboCup Adult Size Humanoid League Runner-up: Team Taiwan**

Ideally, Cornell Cup's C-3PO design would exhibit the aforementioned 6 DOF per leg: hip yaw, hip roll, hip pitch, knee pitch, ankle pitch, and ankle roll. However, it was important to evaluate in more detail the need and mechanical feasibility for these degrees of freedom with a decision matrix.

### 3.3 Initial Concepts

In order to meet the turning requirement, several turning methods and mechanisms were brainstormed. Primarily, if the walking mechanism had at least five degrees of freedom, the joints would be able to be controlled in such a way that would facilitate turning. The additional turning mechanisms that would work regardless of degrees of freedom are contained in Figures 5, 6, 7, and 8.

### 3.3.1 Pivot and Locking Turning Mechanism

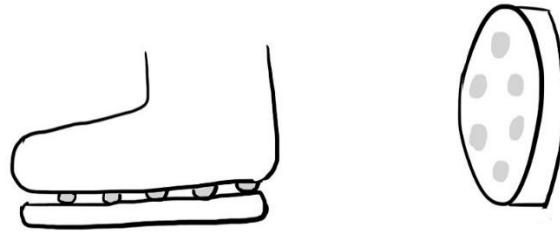

**Figure 5: Pivot and Locking Turning Mechanism**

The pivot and locking mechanism contained a flat circular plate, ball bearings, and a break to lock the plate in place. It was hypothesized that it could work by rotating the torso, which would in turn cause the lower half of the robot to turn the opposite direction by principle of momentum conservation. Then, the break would lock the plate in place, and the torso would rotate such that it faced the same direction as the feet.

### 3.3.2 Wheel Turning Mechanism

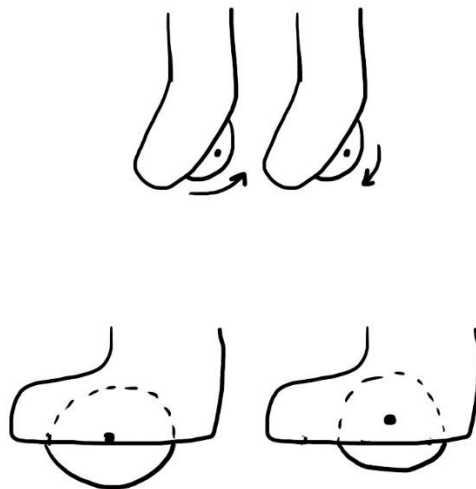

**Figure 6: Wheel Turning Mechanism**

Having wheels in the feet rotate in opposite would allow the robot to turn. Issues that arose were that the wheels would have to have enough power and traction to move 150 lbs or more. In addition, if the foot no longer touched the ground, the leg could pivot the drive axle.

### 3.3.3 Heely Turning Mechanism



**Figure 7: Heely Turning Mechanism**

The Heely turning mechanism worked much like the wheel turning mechanism except the foot would be on the ground during the majority of the time, then weight would be shifted back on to the Heely wheel for turning. However, the weight shifting and motion required to have the mechanism rest on the wheel would have been just as difficult as having enough degrees of freedom to be able to turn without the mechanism.

### 3.3.4 Tank Tread Turning Mechanism

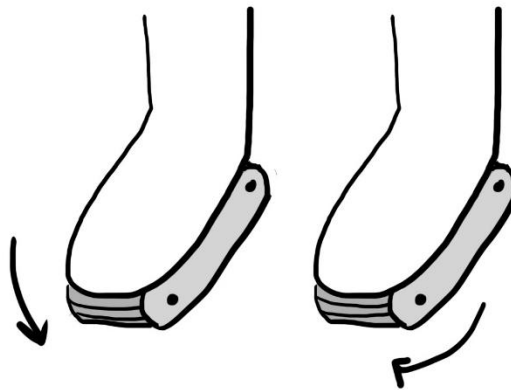

**Figure 8: Tank Tread Turning Mechanism**

Similar to the wheel mechanism, the tank tread mechanism would work by having the tread on each foot rotate in opposite directions. The motors would have to be powerful enough to move the entire weight of C-3PO.

### 3.3.5 Cam Shaft/Baby Doll Turning Mechanism

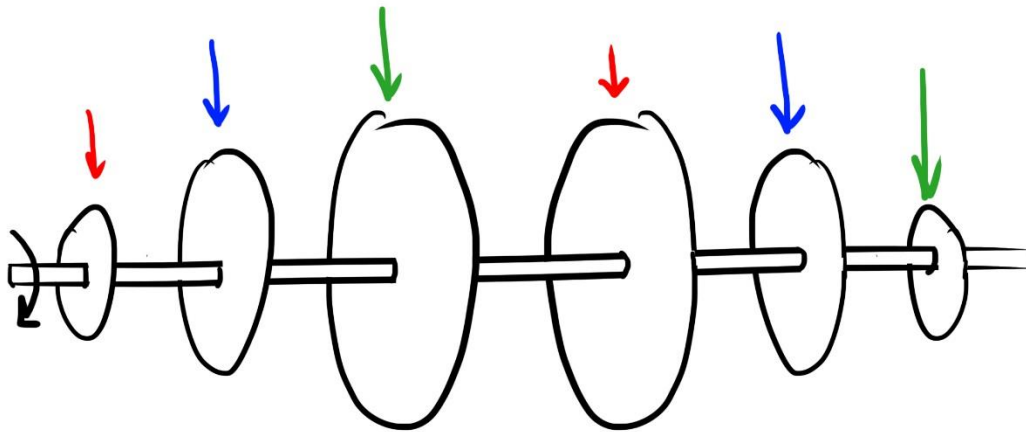

**Figure 9: Cam Shaft/Baby Doll Turning Mechanism**

The cam shaft mechanism was inspired by a children's walking doll found in the lab. The idea behind it was that if each hip were to move along differently sized paths, making the steps different sizes, the robot would slowly be able to change direction. In Figure 9, the blue circular path for each hip joint would ensure both legs took the same step length, and therefore the robot would move straight forward. The red circular paths would mean the left leg would have a smaller step than the right, making the robot turn left and vice versa with the green path. Though the concept was clear, the design needed to accomplish this turning mechanism was unclear.

## 4 Decision Matrices

### 4.1 Walking Degrees of Freedom

The first design decision that had to be made for C-3PO's walking mechanism was the number of degrees of freedom each leg would have. The degrees of freedom dictate the motion of the leg, but also its complexity in terms of both design and control. A decision matrix was created to be able to decide between the number of degrees of freedom and which joint and type the degree of freedom was. Criteria were chosen to help differentiate each mechanisms strengths and weaknesses, along with a defined rating system and weights. The Static 6 DOF mechanism received the highest total, and it was the idea presented at the team meeting.

# Walking DOF

3 DOF Static (no turning) (hip: pitch, knee: pitch, ankle: pitch)

4 DOF Static (no turning) (hip: pitch, knee: pitch, ankle: pitch and yaw)

5 DOF Static (hip: pitch and roll, knee: pitch, ankle: pitch and yaw) TURN

6 DOF Static (hip: pitch, roll and yaw, knee: pitch, ankle: pitch and yaw)

Criteria	Rating Explanations	Weight	Rating	Weighted Rating	Rating	Weighted Rating	Rating	Weighted Rating	Rating	Weighted Rating
Mechanism design difficulty	5: 1 week 3: 2 weeks 1: 4+ weeks	5	2	10	2	10	2	10	2	10
Ease of Machinability	5: 1 week 3: 2 weeks 1: 5+ weeks	5	3	15	2	10	2	10	2	10
Manufacturability (premade components?)	5: >50% premade 3: 25% premade 1: <10% premade	5	3	15	2	10	2	10	2	10
Ease of Assembly	5: 1 hour 3: 2 hours 1: >3 hours	5	3	15	2	10	2	10	2	10
Weight Shifting	5: yes 1: no	5	1	5	1	5	1	5	5	25
Modularity	5: 100% modular 3: 50% modular 1: <25% modular	2	4	8	3	6	2	4	1	2
Ease of Interfacing with Rest of Body	5: <2 hours 3: 4 hours 1: >8 hours	4	5	20	5	20	2	8	2	8
Speed	5: 2 ft/s 3: 6 in./s 1: 2 in./s	2	1	2	1	2	2	4	2	4
Ability to turn	5: Yes 1: No	5	1	5	1	5	5	25	5	25
Stability	5: Falls over once every 15 minutes 3: Falls once every 5 minutes 1: Falls over once every minute	4	1	4	2	8	3	12	4	16
Controls difficulty	5: easish 3: okish 1: hardish	4	4	16	4	16	3	12	2	8
ECE difficulty	5: few wires 3: a decent amount 1: shit ton of wires tangled in chaos	2	4	8	4	8	3	6	2	4
Weight	5: kindergartener can carry 3: Lijia can	1	2	2	2	2	3	3	4	4

	carry 1: Arnold Schwarzenig ger									
Number of Actuated Components	5: <=1 3: 3 1: >5	3	3	9	3	9	2	6	1	3
Level of Dave Happiness	5: gives us an air mattress and unlimited pizza 3: smiles 1: storms off in a rage	1	1	1	2	2	3	3	4	4
Adaptability for fallback	5: yes 1: no	0.5	1	0.5	1	0.5	5	2.5	5	2.5
Stride Length	5: 1.5 ft 3: 6-10 in 1: 1 in	1	3	3	3	3	3	3	4	4
Noise Level	1:>80dB 3 = 50-70dB 5 = <50dB	0.5	3	1.5	3	1.5	3	1.5	2	1
Cost	5: <\$500 3: \$1000- \$2000 1: >\$4000	1	5	5	4	4	3	3	2	2
<b>Total</b>				145		132		138		152.5

**Table 3: Partial Walking Mechanism Degree of Freedom Decision Matrix**

## 4.2 Turning Mechanisms

Because a leg with 3 DOF or less cannot turn due to mechanical constraints, a separate turning mechanism had to be designed in order to meet the performance requirement. Using the same methodologies as in the previous decision matrix, a turning mechanism decision matrix was created. The mechanisms are described in Figures 41, 42, 43, 44, and 45. The tank tread mechanism scored the highest and would most likely be pursued next semester or if time permits.



Turning Mechanism		Pivoting and Locking Plate		Heelys		Wheels		Tank Tread		Baby Doll (CAM)		
Criteria	Rating Explanations	Weight	Rating	Weighted Rating	Rating	Weighted Rating	Rating	Weighted Rating	Rating	Weighted Rating	Rating	Weighted Rating
Mechanism design difficulty	5: 1 week 3: 2 weeks 1: 4+ weeks	5	5	25	4	20	4	20	3	15	1	5
Ease of Machinability	5: 1 week 3: 2 weeks 1: 5+ weeks	5	3	15	4	20	4	20	5	25	1	5
Manufacturability (amt. premade components)	5: >50% premade 3: 25% premade 1: <10% premade	5	3	15	4	20	3.5	17.5	4	20	1	5
Ease of Assembly	5: 1 hour 3: 2 hours 1: >3 hours	5	3	15	2	10	2	10	2	10	1	5
Modularity	5: 100% modular 3: 50% modular 1: <25% modular	2	2	4	4	8	4	8	4	8	2	4
Speed	5: 20deg/s 3: 10deg/s 1: <5deg/s	2	1	2	4	8	4	8	5	10	3	6
Stability	5: Falls over <2% of time 3: Falls over 10% of time 1: Falls over >30% of time	4	4	16	2	8	2	8	5	20	2	8
Controls difficulty	5: easish 3: okish 1: hardish	3	2	6	3	9	3	9	4	12	2	6
ECE difficulty	5: few wires 3: a decent amount 1: shit ton of wires tangled in chaos	2	3	6	2	4	2	4	2	4	3	6
Weight	5: kindergartener can carry 3: Lijja can carry 1: Arnold Schwarzenegger	1	4	4	5	5	4	4	4	4	3	3
Number of	5: 1	1	2	2	3	3	3	3	1	1	1	1

Components	3: 3 1: >5												
Number of Actuated Components	5: <=1 3: 3 1: >5	3	2	6	2	6	2	6	5	15	1	3	
Level of Dave Happiness	5: gives us an air mattress and unlimited pizza 3: smiles 1: storms off in a rage	1	2	2	3	3	3	3	4	4	3	3	
Adaptability for fallback	5: yes 1: no	0.5	1	0.5	1	0.5	1	0.5	5	2.5	1	0.5	
Height foot will be picked up	5: 6 in 3: 2-4 in 1: <0.25 in	1	1	1	1	1	1	1	1	1	2	2	
Noise Level	1: 70-90dB 3 = 50-70dB 5 = <50dB	0.5	4	2	4	2	4	2	3	1.5	3	1.5	
Ability to maintain traction	5: Slips less than .5 in 3: Slips between 1-3 in 1: Slips more than 5 in	3	5	15	5	15	5	15	5	15	5	15	
Cost	5: <\$500 3: \$1000-\$2000 1: >\$4000	1	4	4	4	4	4	4	4	4	3	3	
<b>Total</b>				140.5		146.5		143		172		82	

Table 4: Turning Mechanism Decision Matrix

## 4.3 Joint Speed Requirements

### 4.3.1 Motivation

Joint speed requirements were needed to help drive a decision on the main drive motor's specifications along with a mass estimate. In order to get a better estimate of the plausible walking speeds, several videos of people walking were taken, the angular speed of the hip joint was analyzed, and MATLAB was used to calculate the required torque. This information was used to get a better of idea of motor availability for our desired walking speeds.

### 4.3.2 Measuring Hip Angular Speed

Once several videos were taken of people walking, a free software called PhysMo was utilized as shown in Figure 10. This software allows the user to measure angles and distances in each frame of the video while providing the time for each frame.

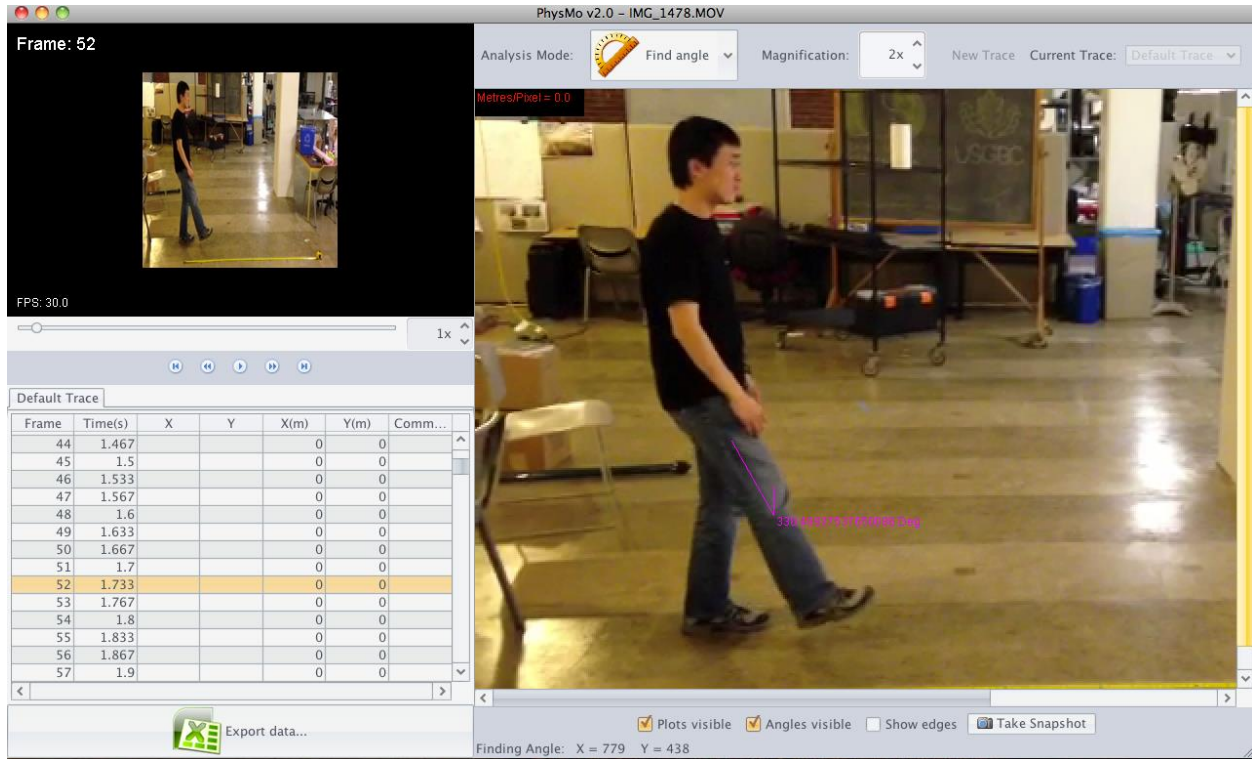
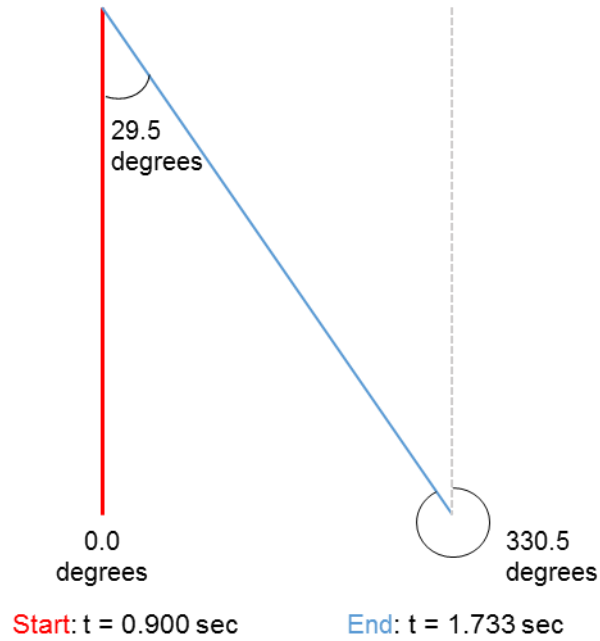

**Figure 10: Example of PhysMo Workspace**

The angle measured is dependent on human input, so the measurements are not perfectly reproducible. However, this estimate is much more accurate than an intuitive estimation.

### 4.3.3 Calculations

Joint speed was calculated by carefully using geometry and the time for each frame, as shown in Figure 11 and the following Equation 1.

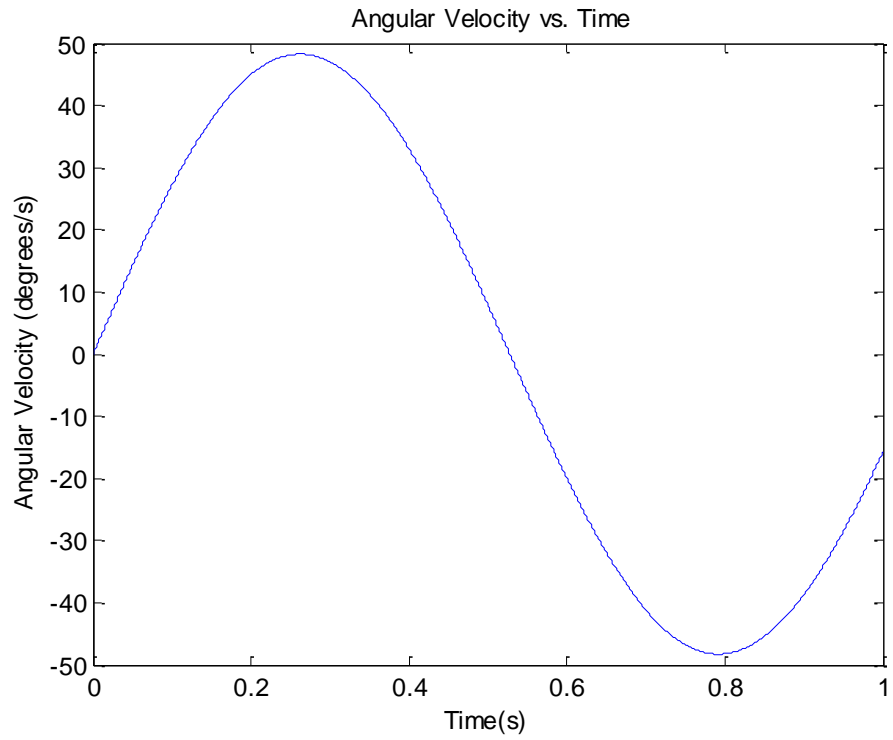

**Figure 11: Leg Position Diagram**

**Equation 1:**

$$\frac{d\theta}{dt} = \frac{\Delta\theta}{\Delta t} = \frac{29.5 \text{ degrees}}{(1.733 \text{ sec} - 0.900 \text{ sec})} = 34.5 \text{ deg/sec}$$

A MATLAB code, seen in Appendix A.1, was developed to calculate the appropriate motor torque by utilizing a numerical guess and check. The user can input motor torque at the operating point, mass, and length of the leg and generate plots of angular velocity versus time and angle from the vertical versus time, shown in Figures 48 and 49. This helped determine whether or not a motor chosen would give the hip motion desired. For the example shown in Fig. 48 and 49 a torque of 100 in/lbs, a mass of 10 kg and a leg length of 0.82 meters (or 2.7 feet) was inputted.



**Figure 12: Angular Velocity of the Hip Joint versus Time**

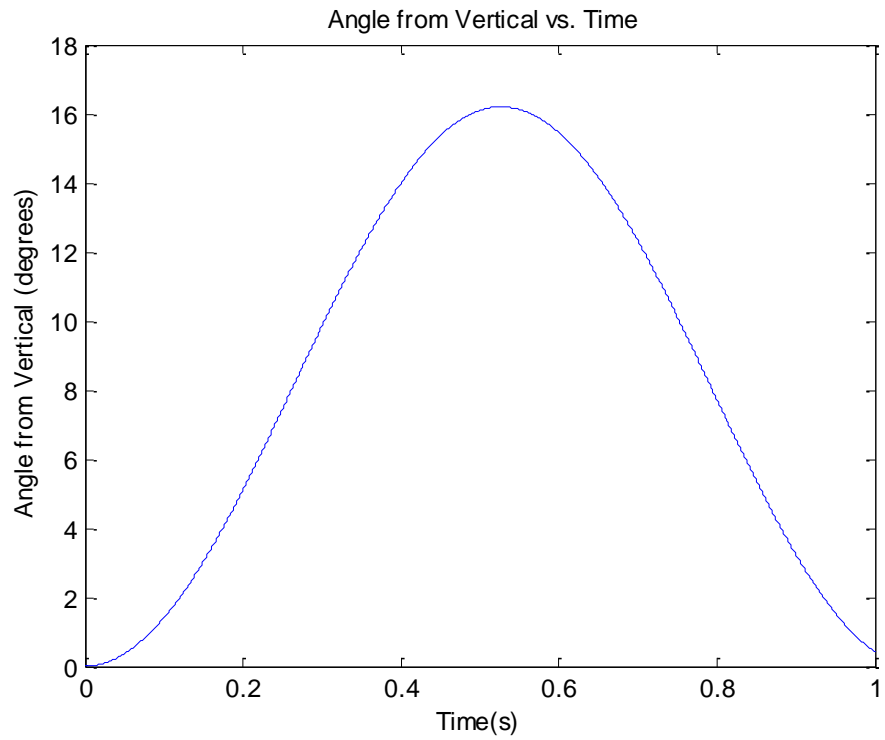

**Figure 13: Angle of Leg from Vertical versus Time**

#### **4.3.4 Conclusions**

After several attempts of recording walking speeds and performing the associated analysis, a hip joint speed of approximately 34.5 degrees/second was chosen. This decision was driven by the desire to minimize torque required while maintaining human-like motion.

### **5 Design Shift: 12DOF to 1DOF**

After completing the joint speed requirements, it was apparent how simplified the calculations for developing the walking mechanism were becoming. In order to develop a 12DOF walking mechanism (6DOF per leg) as planned, estimates for the speed of each degree of freedom for each joint would need to be developed, subsequent motors would need to be selected, and all the components would need to be modified and iterated upon once all of the components were put together. The problem of walking would then reduce a series of recalibrations of the different electrical components and code until the solution was functional, and even then its success would not be guaranteed. There would be very few intermediate milestones that could be tested along the way to ensure that the system as a whole would function as planned by the given date. With these considerations in mind, the team chose to simplify the problem into as few degrees of freedom as possible that would achieve the original goal of the system translating forward with a walking-like motion. This would reduce the number of components for troubleshooting (thus reducing time spent), reduce the number of motors to be purchased (thus reducing cost), reduce the weight of the system, and provide insight to developing a more complex and realistic solution in the future. After much consideration, the team developed two solutions that utilized only 1DOF for both legs.

### **6 Final Design: Four-Bar Linkage Mechanism, 1 DOF**

#### **6.1 Design Overview**

After it was decided that the 12 DOF walking mechanism would be simplified to a 1 DOF system, the four-bar linkage design was created. The inspiration of this design came from wind-up walking toys. In such a toy, a single wind-up clockwork motor powers the entire walking motion. The motor is mechanically linked to a series of gears such that the entire system only has 1 DOF. The upper end of each leg is constrained to move in a circle with a fixed radius about the hip joint. At the same time, the two upper ends are constrained to be always on the exact opposite side of the circle (i.e. 180 degrees apart). In addition, both legs are constrained to be permanently vertical.

This mechanism creates a kinematically constrained walking motion with a sinusoidal variance in speed given a constant motor RPM. The motion of this mechanism is perfectly symmetrical forwards and backwards, so such a design allows for the ability to walk in both directions. However, due to the fact that there is only 1 DOF, the system can only walk in a

straight line and lacks the ability to make turns. Despite this drawback, this mechanism was chosen due to its simplicity and robustness. It was decided that having just the ability to walk in a straight line is sufficient for the first iteration of C-3PO.

The overall mechanical motion of the wind-up toy mechanism was implemented on the four-bar linkage design. However, one undesirable trait of the wind-up toy mechanism is its gearing system. Due to the lack of experience on using gears, it was decided that the gearing system would be replaced with a different mechanism that performs the same function. This mechanism was the four-bar linkage. The four bars in this system are: the top crank, the bottom crank, the leg, and the base plate. The top crank fixes the radius of the circle about which the top of the leg moves. The presence of the bottom crank in conjunction with the top crank keeps the leg always parallel to the base plate. The base plate is the “ground link” of the four-bar linkage; it does not move and is rigidly attached to the torso, resulting in the leg being always parallel to the torso, and hence perpendicular to the ground when C-3PO is upright. Figure 14 shows the CAD model of the four-bar linkage mechanism.

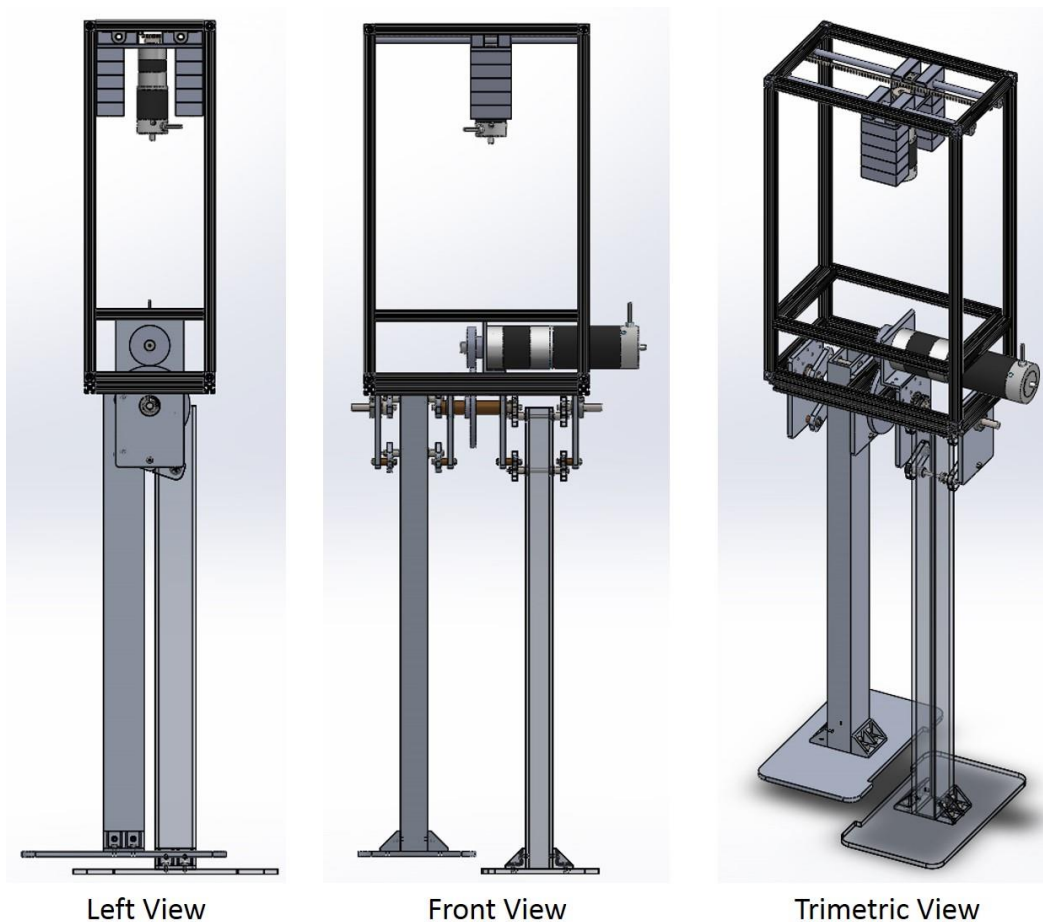

**Figure 14: Design 1: Four-Bar Linkage Mechanism**

The actuation system for this mechanism is fairly simple. The motor is mounted on the torso and is geared to the central driveshaft, which sits in two steel ball bearings. The motor actuates the driveshaft via a 2:1 gear ratio. The driveshaft turns the inner top crank of both legs, resulting in the circular motion of the legs' top joints. The lower and outer cranks and the outer driveshafts (all sitting in ball bearings) guide the four-bar linkage in a prescribed, 1 DOF motion. The result is the kinematically constrained walking motion described above.

## 6.2 Weight-Shifting Mechanism

The wind-up toy has wide, forked feet that cross over each other, so its center of gravity never moves outside of the contact area of either foot. As such, it can lift a foot at any time and still remain balanced on its other foot. On the other hand, for aesthetic reasons, it is undesirable for C-3PO to have such crossed-over feet. So a weight shifting mechanism in the torso was devised in order to apply a counter-force that would balance C-3PO as it walks.

This mechanism must move at the same frequency as the four-bar linkage. In addition, it must start in the correct position corresponding to the angular position of the four-bar linkage. As a result, an encoder is needed for the motor actuating the four-bar linkage (the walking motor). This way, the velocity and position of the walking motor can be reported to the controller of the weight-shifting motor, ensuring that the weight-shifting mechanism runs at the correct speed.

The weight-shifting mechanism contains an actuating motor attached to ten 1.7-pound deadweights, resulting in a total of 22 pounds of shifting weight. Each time C-3PO takes a step, the motor accelerates the weight in the direction of the foot that is lifted off of the ground. This results in an equal and opposite reaction force that keeps C-3PO upright. Figure 15 shows an annotated CAD model of the walking mechanism with the weight-shifting mechanism.



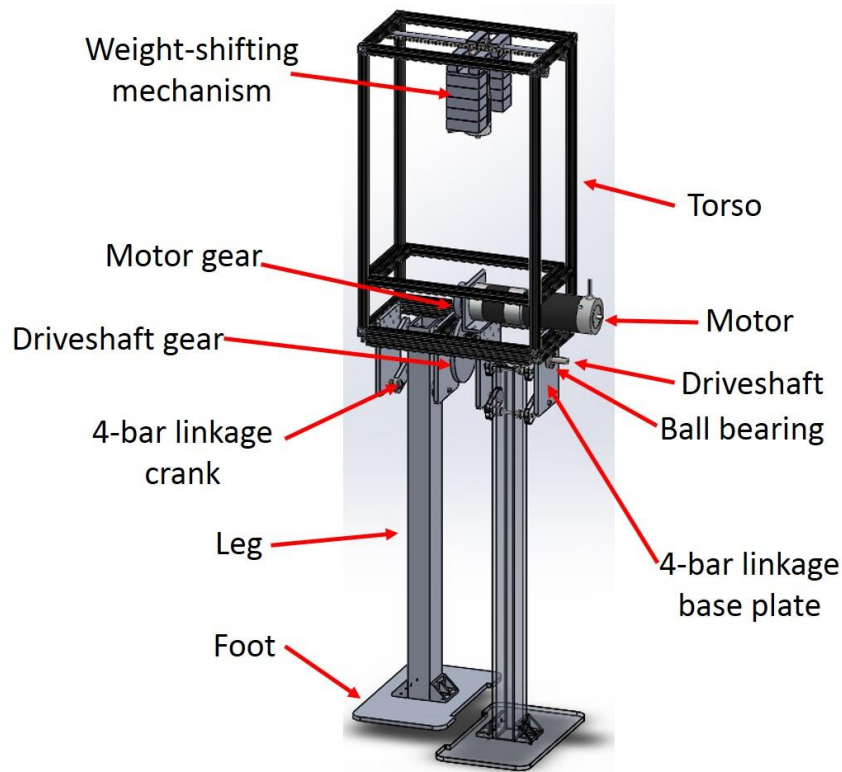

**Figure 15: Annotated Four-Bar Linkage Walking Mechanism**

### 6.3 Finite Element Analysis of the Ankles

Using ANSYS, finite element analysis (FEA) was performed in order to validate the structural integrity of the system. There are two locations of concern in regards to structural integrity: the bearing joints on the four-bar linkages and the bolted joints at the ankles. The joints on the four-bar linkages are not easily analyzable via FEA, therefore they were oversized to ensure that they can withstand the loads that they are required to. The ankle, on the other hand, is fairly straight forward to analyze via FEA. Therefore, they were analyzed in order to potentially reduce mass.

#### **FEA Setup:**

To set up the FEA, a leg, a foot, and two ankle brackets were imported into ANSYS as an assembly. Internally, each ankle bracket was connected to the leg and foot by revolute joints at the screw holes. Two external conditions were applied: a fixed support on the bottom surface of the foot and a lateral force applied near the top of the leg. The fixed support simulated the fact that the ground would be in solid contact with the bottom of the foot when C-3PO takes a step. The lateral force was a simple way to simulate the bending moment that the center of mass of C-3PO applies on the leg when it takes a step. The force was 50 pounds applied equally on both bearing holes and was in line with their axes. Figure 16 shows the support and the force.

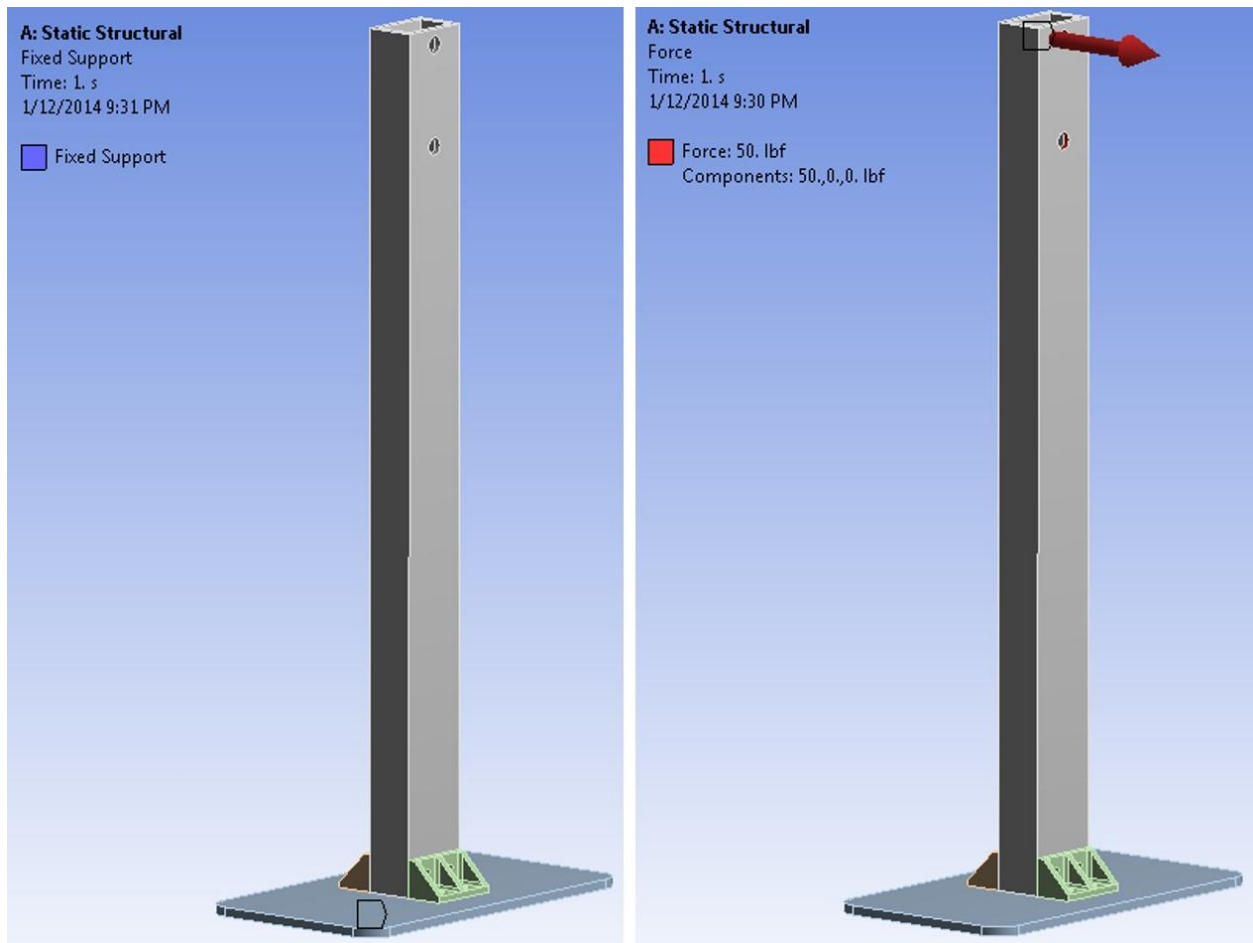

**Figure 16: FEA Setup: External Support and Load**

### **FEA Results:**

As shown in Figure 17, the FEA results indicated that the maximum von-Mises equivalent stress occurred at the ankle bracket. It had a value of 1,915 psi. This was 20 times less than the yield strength of aluminum 6061-T6 (40,000 psi), which the ankle bracket was made of. As a result, the safety factor against yielding was 20. This was quite adequate for the purposes of C-3PO, meaning that the ankle joint was structurally sound. In addition, the maximum deformation that occurred at the top of the leg was 0.044 inches, which is quite insignificant, meaning that the leg should stay rigid during operation. Overall, the FEA results indicated that the leg-ankle-foot assembly had good structural integrity.

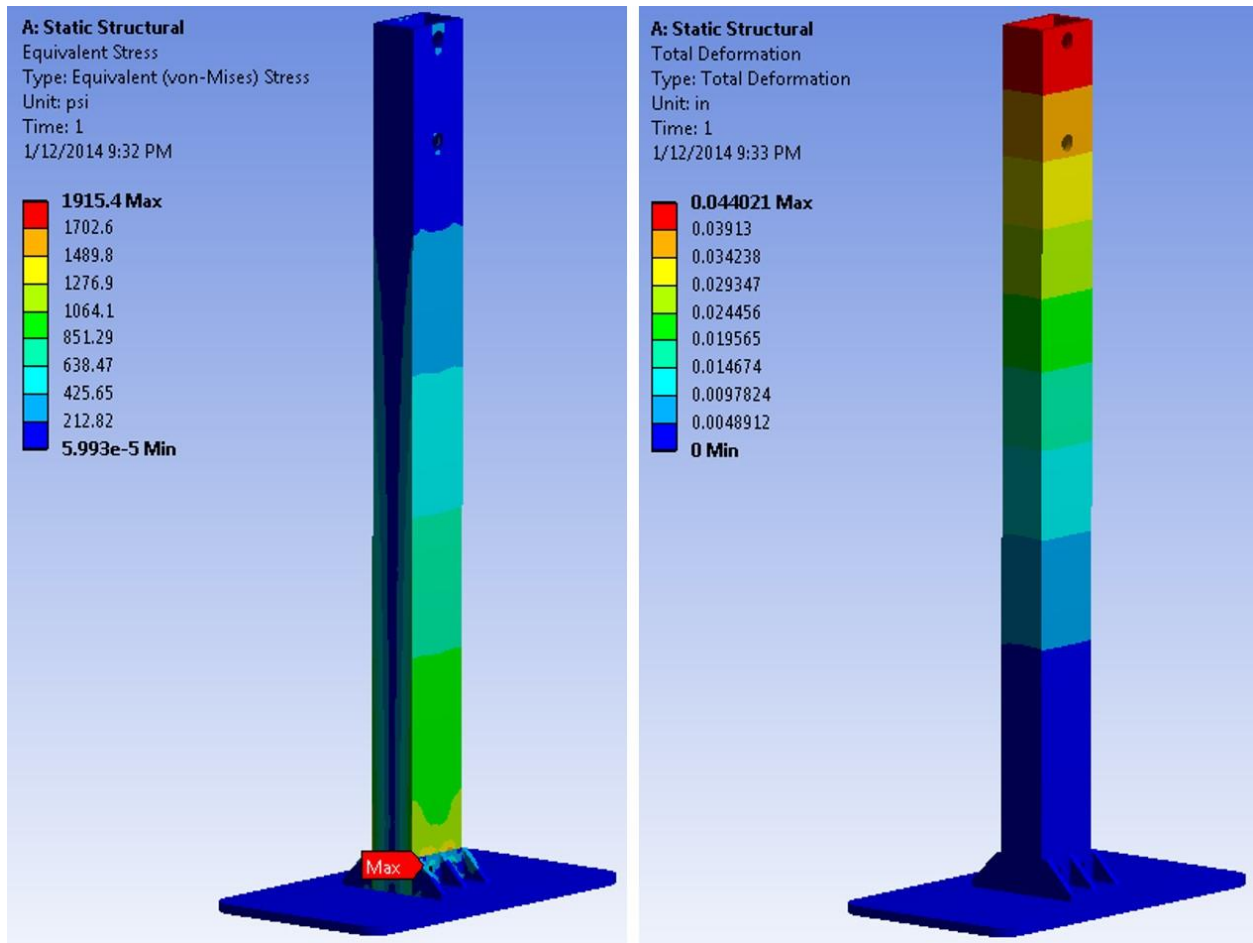

**Figure 17: FEA Results: von-Mises Equivalent Stress and Total Deformation**

## 6.4 Leg to Torso Integration

In order to integrate the legs with the torso, several design considerations had to be taken into account. The t-slotted bar has a cross section cannot be drilled into for large bolts, such as ¼-20. Instead, several 10-24 clearance holes were drilled in an alternating offset pattern, as seen in Figure 18. This pattern allows the interface to withstand forcing and torquing well.

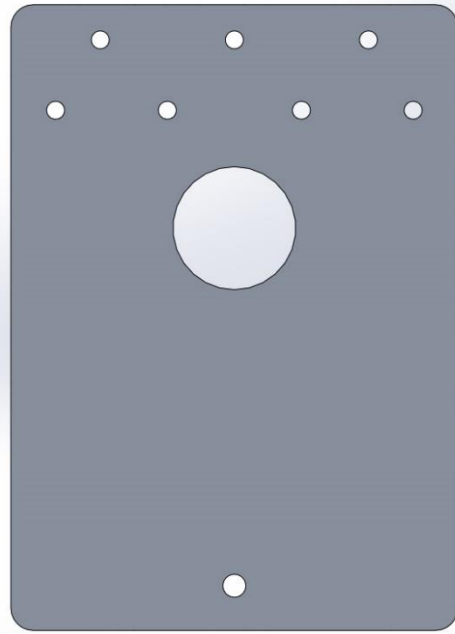

**Figure 18: Offset Bolt Hole Array**

Additionally, the leg motor protrudes into the torso, so spacing was critical. The face plate mount in Figure 19 constrains the motor horizontally and the steel two-hole clamp holds the motor in the correct vertical position. Both of these connection methods ensure the motor gear meshes with the driveshaft gear at all points during the cycle without slipping. Adhesive-backed rubber was added to the inner surface of the clamp to dampen vibration caused during the walking motion to prevent damage to the motor.

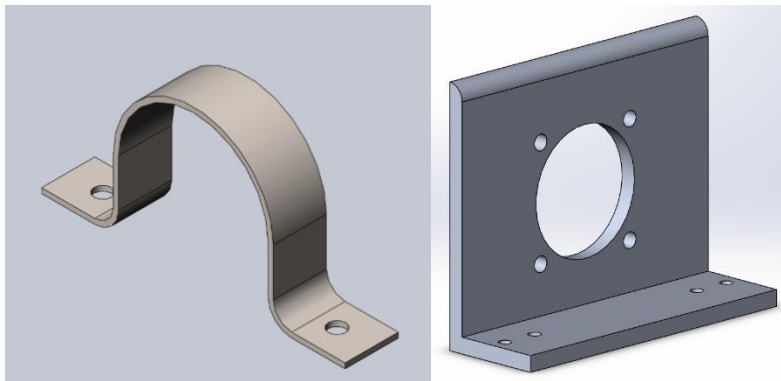

**Figure 19: Motor Mounting Fixtures**

A difficult component of creating C-3PO's walking mechanism was the upper leg assembly and integration with the torso. As seen in Figure 18, there were seven holes drilled in each vertical link base plate, but not all were utilized for the torso-leg integration. This was because some of screws would interfere with the crank motion. In addition, a few of the screws for the inner plates were un-installable due to tight spacing. Regardless, each plate had at least four of the

seven holes utilized. Due to this, the integration was still robust enough to handle the forces placed on the system. Fortunately, it is very easy to adjust the position of t-slotted bar; positioning the cross beams (oriented front to back) in order to bolt the legs to the torso did not require precise tolerancing. This was also the case when clamping the leg motor to the t-slotted bar above it. Figure 20 shows the hip area of the fully assembled and integrated system.

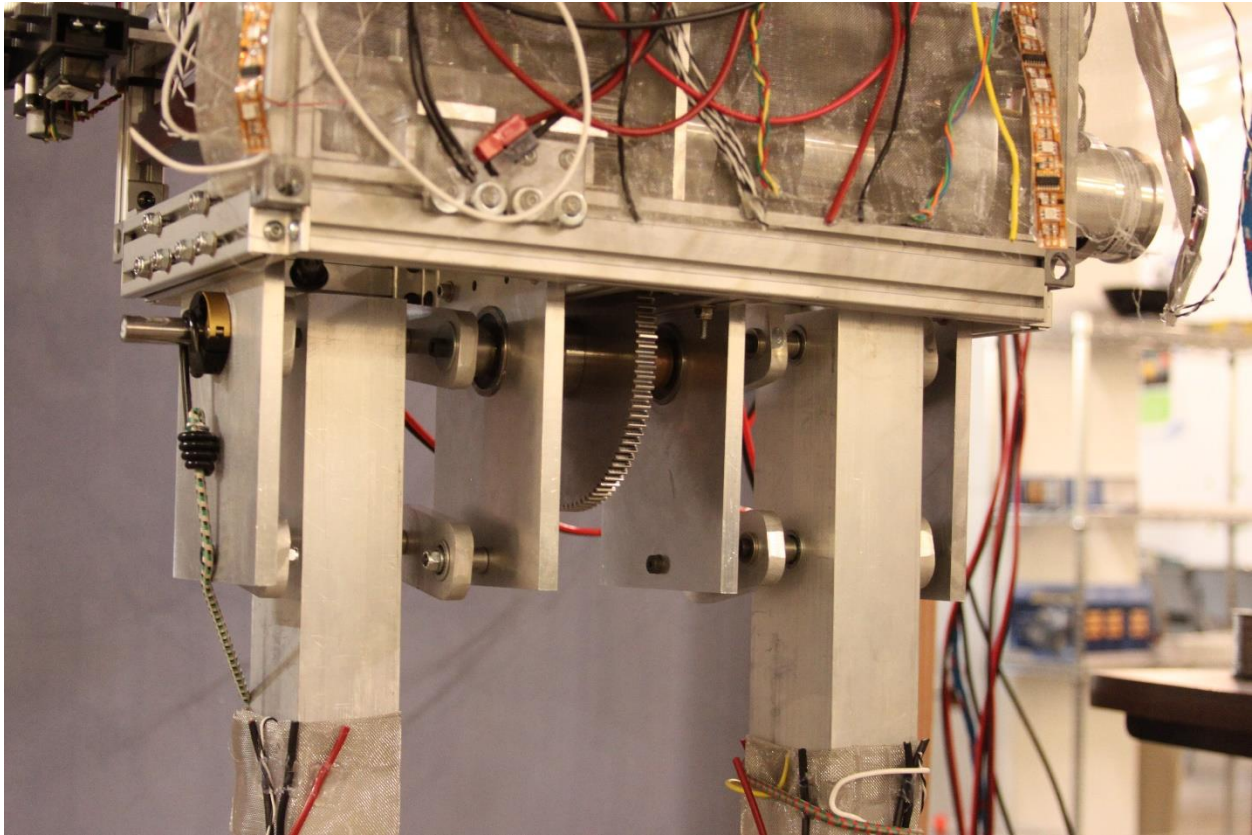

**Figure 20: Fully Assembled and Integrated Four-Bar Linkage Mechanism**

## 6.5 Manufacturing: Major Components

Most of the major components of the system were made from aluminum 6061-T6 stock. This was due to the fact that aluminum 6061-T6 is a relatively strong, lightweight, and low-price material.

### **Cranks:**

All the crank pieces were machined from two 12" x 12" x 3/8" aluminum plates. A good rule of thumb is to carefully mark where you will be cutting the pieces from and to allow ample space between pieces. This allows for some error when using a drop saw or scroll saw. When

machining the upper and lower crank pieces as shown in Figure 21, the distance between the two holes is the most critical dimension, as it ensures each leg has the same motion radius. In order to get the correct fillet radii on the corners, it is useful to print a to-scale drawing of the part. That way, more consistent results can be achieved with a grinder by directly placing the part on the drawing.



**Figure 21: Cranks in Various Machining Stages**

#### **Legs:**

The legs were relatively straightforward to machine. There were only three operations needed: cut the leg to length from the stock, drill and ream the bearing holes, and drill and tap the holes for bolting on the ankle bracket. The one operation that needed to be precise was the drilling and reaming of the bearing holes. Otherwise, the bearings would not be able to be press-fitted snugly into the leg.

#### **Ankle bracket:**

There were a total of four ankle brackets, two on each ankle. Each bracket was made from a 3" x 1.5" x 1.5" aluminum blocks. One difficult part about machining the bracket was the 45° cut that needed to be made on one edge. On the milling machine, this cut can be accomplished by placing a 45° angle block below the stock inside the vise. This will hold the stock block at a 45° angle with one edge directly facing upwards. A regular end mill can then be used to cut away the edge, resulting in the desired 45° cut. Another difficult part about machining the bracket was the rounded fillets on its cutouts. A regular end mill would only be able to make square corner cuts, with no fillets to alleviate stress concentration. Hence, a ball-end end mill was purchased from McMaster-Carr for the purpose of machining the cutouts on the ankle brackets.

**Feet:**

Another difficult component to machine was the foot. Due to its large size, the long edges (15") could not be milled down while held in the vise in a horizontal manner. So it must be held vertically in the vise. When holding it in such a manner, care must be taken to minimize vibrations during machining.

**Motor Gear Spacer:**

Finally, the process of machining the motor gear spacer (0.25"-thick, 18-8 stainless steel washer) to fit over the motor shaft key required broaching. The machine shop at Cornell University had a broaching set for this purpose, so a 6mm wide by 3 mm deep keyway was made. The downside is that if a set is not available, it runs at a fairly high price (\$40+), so an alternate solution is to choose a thick washer with an inner diameter that would fit over both the shaft and the key. Since the washer is used for a spacing purpose only, there is no harm in using this method, though the aesthetics may suffer slightly.

## 7 Motor Selection

The four-bar linkage walking mechanism has a single degree of freedom, so a single DC motor is used to actuate it. In addition, due to the kinematically constrained walking motion, no motor speed control is needed. Therefore, it was decided that a brushed motor would be used, since it does not require a controller for fixed speeds and costs less. In addition, due to the fact that the torque required is very high while the RPM required is very low, the motor needs to have a planetary gearhead to dramatically increase the gear ratio in order to trade RPM for torque. One other requirement is that the voltage of the motor must not exceed 24 volts, as dictated by the electrical power board used in C-3PO. Lastly, since the phase of the leg motion needs to match the position of the shifting mass in the torso, an optical encoder is needed for the motor.

## 7.1 The Physical Setup

- C-3PO total weight  $\approx$  150 lbs
- Weight of each leg  $\approx$  15 lbs
- Desired walking speed  $\approx$  1 ft/s
- Motor to driveshaft gear ratio = 2:1

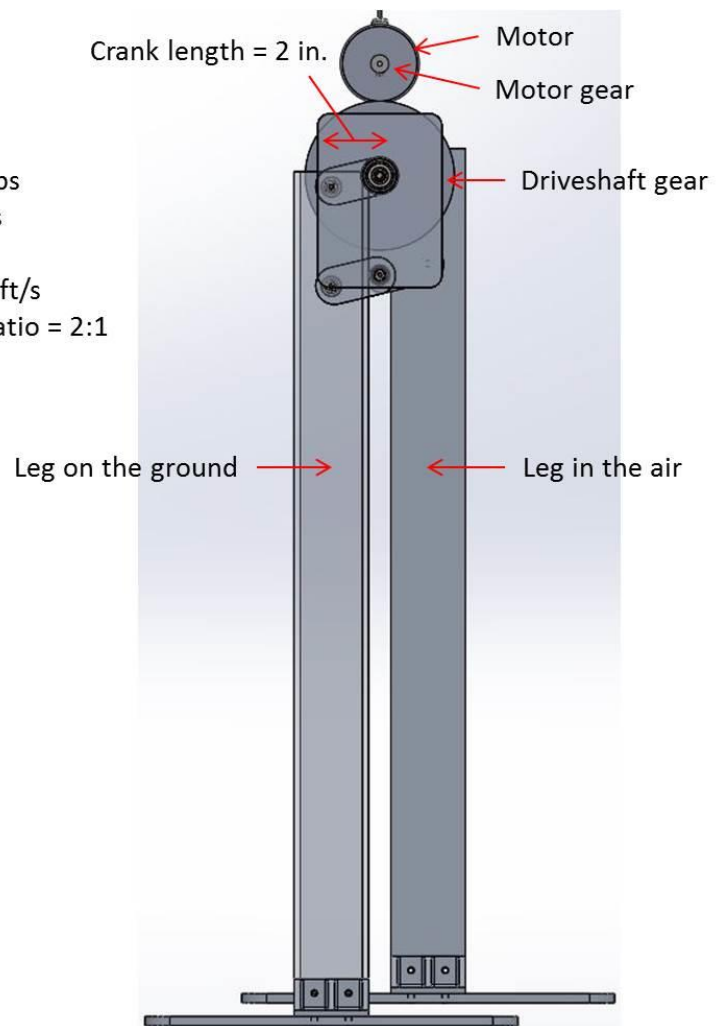

**Figure 22: Design 1 Physical Set-up**



## 7.2 Free Body Diagram

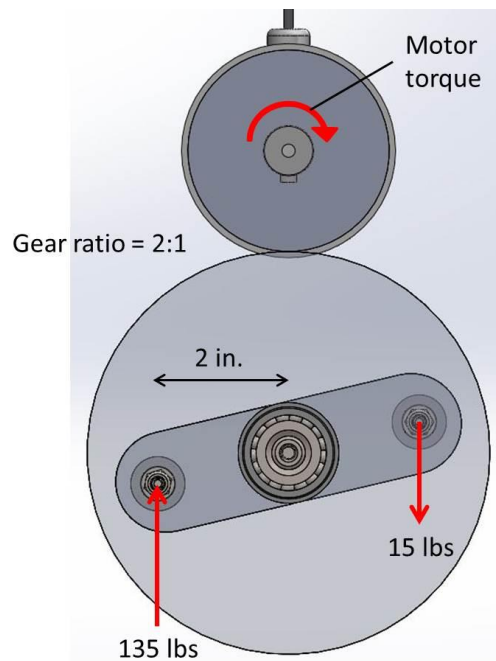

Figure 23: Free Body Diagram of Gear Ratio

## 7.3 Motor Torque Requirement Calculations

Variables:

$F_1$  = force from leg 1 (leg on the ground) on crank = 135 lbs

$F_2$  = force from leg 2 (leg in the air) on crank = 15 lbs

$L$  = crank length = 2 in.

$GR$  = gear ratio of motor to driveshaft = 2:1

$T$  = motor torque

Based on the laws of mechanics, the following equation applies:

$$F_1 * L + F_2 * L = GR * T$$

$$\rightarrow T = (F_1 * L + F_2 * L) / GR$$

$$T = (135 \text{ lbs} * 2 \text{ in.} + 15 \text{ lbs} * 2 \text{ in.}) / 2$$

$$T = 150 \text{ in-lbs}$$

Now, since the weight of C-3PO is a rough estimate and power losses due to friction have not been taken into account, it is better to err on the side of caution and over-spec the motor torque by about 30%.

$$\text{So: } T_{\text{spec}} = 1.3 * T$$

$$\rightarrow T_{\text{spec}} \approx 200 \text{ in-lbs}$$

## 7.4 RPM Requirement Calculations

Variables:

$v$  = desired C-3PO walking speed  $\approx 12$  in./s

GR = gear ratio of motor to driveshaft = 2:1

$L$  = crank length = 2 in.

$f_m$  = motor revolutions per second

Based on kinematic constraints of the walking mechanism, the following equation applies:

$$v = f_m / GR * 4L$$

$$\rightarrow f_m = v / 4L * GR$$

$$f_m = (12 \text{ in./s}) / (4 * 2 \text{ in.}) * 2$$

$$f_m = 3 \text{ rev/s}$$

$$\text{RPM}_{\text{motor}} = 60 \text{ s/min} * f_m$$

$$\text{RPM}_{\text{motor}} = \mathbf{180 \text{ RPM}}$$

## 7.5 Basic Spec Summary

Motor shaft output torque  $\approx$  **200 in-lbs**

Motor shaft output speed  $\approx$  **180 RPM**

## 7.6 Final Decision

The final motor choice is a DC brushed planetary gearmotor sold by Midwest Motion Products.

Part number: MMP D33-655B-24V GP81-025 (with EU series optical encoder)

### Motor specifications:

Gearhead shaft output torque: 202 in-lbs

Gearhead shaft output speed (at full torque): 160 RPM

Rated DC voltage: 24 volts

Rated continuous current: 23.9 amperes

## 8 Bill of Materials

Motor Mount Parts				
Used For	Item	Part Number	Vendor	Quantity Used
Motor mount	Steel Two-Hole Clamp	9439T16	McMaster	1
Motor Face Mount	Multipurpose 6061 Aluminum, 90 Degree	8982K58	McMaster	5" long, 4" x 1.6383" legs,

	Angle, 1/4" Thick, 2" x 4" Legs, length: 1ft			1/4" thick
Adhesive-backed Rubber	Ultra-Strength Neoprene Rubber, Adhesive-Back, 1/4" Thick, 2" Width, 36" Long, Hardness: 50A (medium)	8463K63	McMaster	8" x 1.25" x 1/8" (approx. thickness)
<b>Machining/Tools</b>				
<b>Used For</b>	<b>Item</b>	<b>Part Number</b>	<b>Vendor</b>	
Cutting ankle bracket	Ball-end end mill	8887A341	McMaster	1
<b>Ankle&amp;Foot&amp;Leg Parts</b>				
<b>Used For</b>	<b>Item</b>	<b>Part Number</b>	<b>Vendor</b>	
Ankle Bracket	Multipurpose 6061 Aluminum (1.5" x 1.5" x 3 feet)	9008K47	McMaster	3" x 1.5" x 1.5", machined 4
Ankle Screws	Thread-Locking Socket Head Cap Screw (1/4"-20, 1/2" long)	91205A537	McMaster	16
Foot	Oversized Multipurpose 6061 Aluminum (3/8" Thick, 18" x 18")	89155K28	McMaster	15" x 8.625", machined 2
Leg	Multipurpose 6061 Aluminum Rectangular Tube (1/4" Wall Thickness, 2" x 3", 3' Length)	6546K283	McMaster	34" long, 2" x 3", machined 2
<b>Motor&amp;Gears</b>				
<b>Used For</b>	<b>Item</b>	<b>Part Number</b>	<b>Vendor</b>	
Motor	Reversible DC Gearmotor with EU Series Encoder	MMP D33-655B-24V GP81-025	Midwest Motion Products	1
Motor Gear	Spur Gear (ISO Class 8, 20 deg. pressure angle, 78mm OD)	A 1C22MYKW15050A	SDP/SI	1
Driveshaft Gear	Spur Gear with Hub (ISO Class 8, 20 deg. pressure angle, 153 mm OD)	A 1C22MYK15100A	SDP/SI	1
<b>Crank Pieces</b>				
<b>Used For</b>	<b>Item</b>	<b>Part Number</b>	<b>Vendor</b>	
Long Crank Shaft	Fully Keyed Precision Drive Shaft with Certificate (3/4" OD, 3/16" Keyway Width, 6" Length)	8488T620	McMaster	1
Short Crank Shaft	Hardened Precision Steel Shaft (1/2" Diameter, 6" L Overall, 1/4"-20 x 1/2" D Tap Both Ends)	6649K100	McMaster	3" long, machined 2
Crank Crank lower	Oversized Multipurpose 6061 Aluminum (3/8"	89155K34	McMaster	2 aluminum plates to

Crank vertical link	Thick, 12" x 12")			machine all pieces
Crank drive				
Crank vertical link middle				
Screws for Cranks onto Shafts	Black-Oxide Alloy Steel Socket Head Cap Screw (1/4"-20, 1/2" long)	91251A537	McMaster	4
Shaft Key	Zinc-Plated Steel Oversized Key Stock (3/16" x 3/16", 12" Length)	98491A117	McMaster	0.75" long
<b>Spacers/ Screws/ Nuts/ Washers</b>				
<b>Used For</b>	<b>Item</b>	<b>Part Number</b>	<b>Vendor</b>	
Small Spacer	18-8 Stainless Steel Unthreaded Spacer (1/2" OD, 1/2" Length)	92320A242	McMaster	8
Large Spacer	18-8 Stainless Steel Unthreaded Spacer (1" OD, 3/8" Length)	92320A403	McMaster	2
Sleeve Bearing (new)	SAE 863 Bronze Sleeve Bearing (for 3/4" Shaft Diameter, 1" OD, 3/8" Length)	2868T178	McMaster	2
Set Screw (for gears)	Thread-Locking Flat Point Set Screw (Nonmarring, Alloy Steel, 8-32 Thread, 1/2" Long)	94495A225	McMaster	2
Small Ball Bearing	Steel Ball Bearing (Flanged Open for 1/4" Shaft Diameter, 11/16" OD, 5/16" W)	6383K213	McMaster	12
New Large Ball Bearing	Steel Ball Bearing (Flanged Double Sealed for 3/4" Shaft Diameter, 1-5/8" OD)	6384K367	McMaster	2
Large Ball Bearing	Steel Ball Bearing (Flanged Open for 1/2" Shaft Diameter, 1-3/8" OD, 1/2" W)	6383K241	McMaster	2
Locknut	Zinc-Plated Grade 2 Steel Nylon-Insert Hex Locknut (10-24 Thread Size, 3/8" Width, 15/64" Height)	90631A011	McMaster	8
Shoulder Screw - 1.25	Alloy Steel Shoulder Screw (1/4" Diameter x 1-1/4" Long Shoulder, 10-24 Thread)	91259A544	McMaster	4
Driveshaft Washer	Zinc-Plated Steel Large-Diameter Flat Washer (1/4" Screw Size, 1" OD, .04"-.06" Thick)	91090A108	McMaster	2
Shaft Washer	Grade 2 Titanium Flat Washer (1/4" Screw Size, 3/4" OD, .03"-.05" Thick)	94051A220	McMaster	2
Motor Gear Spacer	18-8 Stainless Steel Thick	98125A036	McMaster	1

	Flat Washer, 3/4" Screw Size, 1-5/8" OD, .23"-.26" Thick			
Shoulder Screw - 4.0	Alloy Steel Shoulder Screw (1/4" Diameter x 4" Long Shoulder, 10-24 Thread)	91259A115	McMaster	4
Driveshaft gear spacer bearing	SAE 841 Bronze Sleeve Bearing, 3/4" Shaft Diameter, 1" OD, 7/8" Length	6391K264	McMaster	1
Driveshaft gear spacer bearing	SAE 841 Bronze Sleeve Bearing, 3/4" Shaft Diameter, 1" OD, 1-3/4" Length	6391K448	McMaster	1
Spacer/bearing between lower cranks and vertical linkage plates	SAE 863 Bronze Sleeve Bearing, 1/4" Shaft Diameter, 1/2" OD, 1/2" Length	2868T48	McMaster	4
C-3PO leg to torso integration	Zinc-Plated Alloy Steel Socket Head Cap Screw, 10-24 Thread, 1-1/2" Length	90128A226	McMaster	40
C-3PO leg to torso integration	18-8 Stainless Steel Nylon-Insert Hex Locknut, 10-24 Thread Size, 3/8" Width, 15/64" Height	91831A011	McMaster	40
C-3PO leg to torso integration	Mil. Spec. Cadmium-Plated Steel Flat Washer, Number 10 Screw Size, .02"-.04" Thick, NAS1149-F0332P	95229A370	McMaster	80
Washers for 1/4"-20 socket head screws	18-8 Stainless Steel General Purpose Flat Washer, 1/4" Screw Size, 5/8" OD, .04"-.06" Thick (100 per pack)	92141A029	McMaster	2
C-3PO leg 1/2" shaft collar	Quick-Release One-Piece Clamp-on Shaft Collar for 1/2" Diameter	1511K12	McMaster	2
<b>OTHER</b>				
<b>Used For</b>	<b>Item</b>	<b>Part Number</b>	<b>Vendor</b>	
Driveshaft and gear interface	1" wide Polyurethane adhesive-backed film	1867T21	McMaster	
Motor shaft and gear interface	2" wide Polyurethane adhesive-backed film	1867T22	McMaster	
Loctite	Loctite® Instant-Bonding Adhesive #430, 1 oz Bottle	66635A32	McMaster	
Foot pad foam (to reduce force of impact)	Natural Gum Foam, 5/16" Thick, 36" Width, Soft	8601K44	McMaster	3" x 5", 4 pads for each foot

**Table 5: C-3PO Walking Mechanism Bill of Materials**

## 9 Testing

Test	Purpose	Outcome	Action
Gear Meshing	Ensure motor placement is correct (when manually rotating legs)	<ol style="list-style-type: none"> <li>1. Shaft rotation yields leg motion for whole cycle</li> <li>2. Shaft rotation does not yield motion for whole cycle</li> </ol>	<ol style="list-style-type: none"> <li>1. None required</li> <li>2. Adjust t-bar and motor mount locations accordingly, document final position</li> </ol>
Suspended Walking	Ensure powered motor rotates legs as expected	<ol style="list-style-type: none"> <li>1. Legs rotate at specified rate</li> <li>2. Leg rotate, but not at specified rate</li> <li>3. Legs do not rotate</li> </ol>	<ol style="list-style-type: none"> <li>1. None required</li> <li>2/3. Determine if cause was mechanical/electrical/coding issue</li> </ol>
Suspended Balancing	Ensure balancing mechanism coincides with steps	<ol style="list-style-type: none"> <li>1. Balancing mechanism coincides with step</li> <li>2. Balancing mechanism does not coincide with step</li> </ol>	<ol style="list-style-type: none"> <li>1. None required</li> <li>2. Determine if cause was mechanical/electrical/coding issue.</li> </ol>
Grounded Walking	Ensure balancing and walking mechanism keep 3PO balanced on ground	<ol style="list-style-type: none"> <li>1. C3PO walks without deviating from an upright position (+/-) for X steps.</li> <li>2. C3PO loses its balance (to be defined)</li> <li>3. C3PO cannot balance</li> </ol>	<ol style="list-style-type: none"> <li>1. None required</li> <li>2. Document time and probable cause</li> <li>3. Determine if cause was mechanical/electrical/coding issue.</li> </ol>

**Table 6: Leg Testing Outline**

Four major testing milestones were developed to gauge the success of the design and the actions to be taken if the milestones were not reached, as outlined in Table 6. Since it was difficult to simulate how the system would behave as a whole, precise criteria for success could not be determined before the

tests were run in some cases. Before any major testing occurred, the leg assembly was rotated manually to ensure the legs could rotate a full cycle. It was noted that at top/bottom dead center (cranks perfectly vertical), would sometimes allow the cranks to rotate in an undesirable direction. This is caused by a singularity at that location. Simulations were run to visualize the issue. The black and blue bars are 4 inches long and represent the distance between the connection points on the vertical link base plates, while the red and green bars are 2 inches long and represent the center to center distance of the crank's holes.

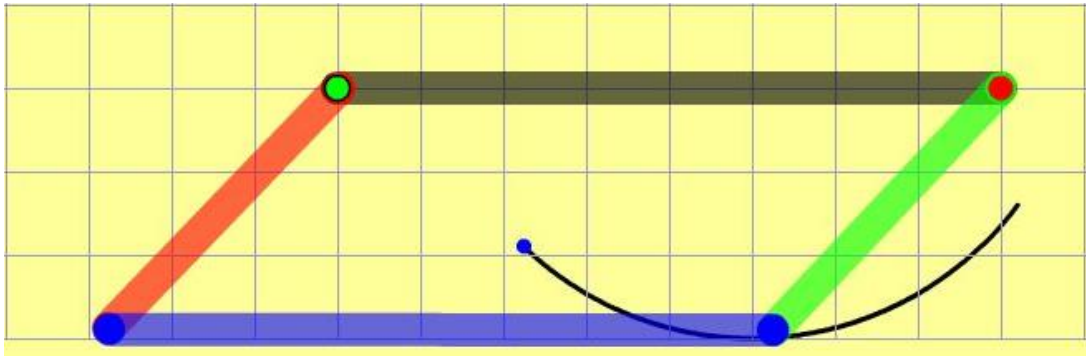

**Figure 24: Four-bar Linkage Simulation, Part 1**

In Figure 24, one can see the four-bar linkage traveling in the fixed-radius path intended, with all cranks parallel.

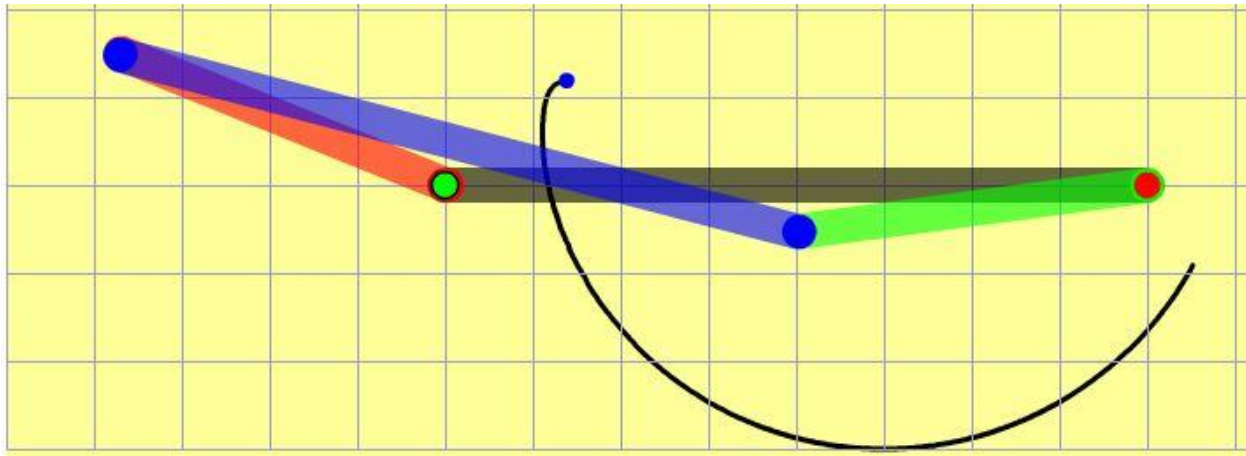
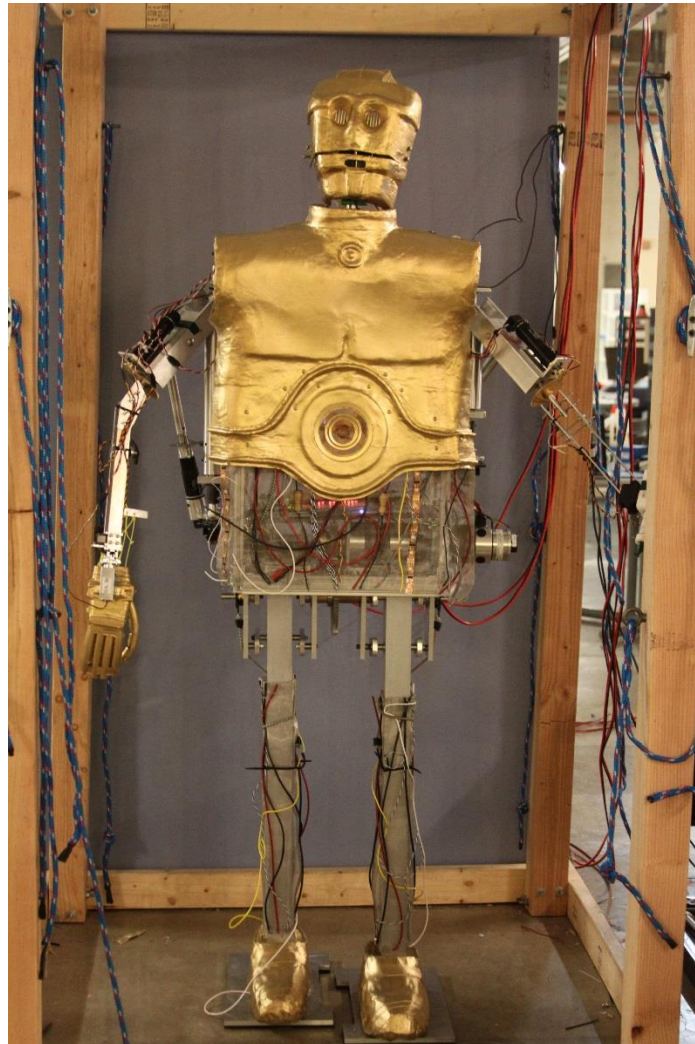

**Figure 25: Four-bar Linkage Simulation, Part 2**

However, once the point where all cranked are aligned has been passed, parallel orientation was sometimes lost (Figure 25). The cranks usually corrected at the start of the next cycle, but this operation was not ideal for walking.

The gears did mesh throughout the entirety of the cycle, so suspended walking was the next test performed. C-3PO was suspended by climbing ropes from a wooden structure, similar to the set-up in Figure 26. The undesirable crank orientation was observed to occur at speeds under 0.25 revolutions per

second, well below the desired walking rate of 0.75 revolutions per second. At or above this speed, the legs were able to rotate without issue. The desired speed was the maximum speed at which the motor could move a 150-lb C-3PO (predicted weight), which is a power-limited operating condition.



**Figure 26: C-3PO Positioned in Testing Rig**

During the suspended walking test, many iterations were done to get the shifting weight to coincide with counteract the walking motion to keep C-3PO upright. When moved to the ground, C-3PO was able to walk up to four steps while inside the testing rig without falling over. As testing went on, the cup-end set screws dug into the driveshaft and caused the cranks to become slightly misaligned. As a result, the cranks were no longer 180° out of phase. The cup-end set screws were chosen for their ability to grip onto shafts, but ultimately dug in too far. At that point in testing, it was impossible to remove the set screws. Flat set screws could have been an alternate solution to prevent them from digging into the driveshaft.

One issue that was encountered during walk testing was the fact that the feet would move inwards each time C-3PO took a step. This would cause C-3PO to step on its own foot and would increase the risk of it



falling over. To resolve this problem, two modifications were implemented. The first modification was to cut out (via the milling machine) sections of the two feet that can potentially overlap. This increased the spacing between the feet without decreasing their effective sizes in terms of weight support. As a result, the feet ended up looking a bit like the wind-up walking toys' feet. The second modification was to attach stiff bungee cords from each hip shaft to the outside of each leg. The tension in the bungee cords helped to keep the legs apart when C-3PO walks. With a combination of these two modifications, the issue of C-3PO stepping on itself was completely resolved.

## **10 Results and Conclusions**

The four-bar linkage mechanism designed was sufficient in driving C-3PO's walking motion. C-3PO was able to take four steps at a time while remaining balanced. However, as more steps were taken, the balancing mechanism was unable to correct the unbalance due to the accumulation of errors. Due to design clearances and flexibility in the bearings, the legs experienced small amounts of undesired inward horizontal motion. Stiff bungee cords were attached from each hip shaft to the outside of each leg in order to keep the legs apart. In addition, the inside of the feet were milled down to prevent the robot from stepping on itself. Although these solutions corrected the issue, walking performance was still inconsistent, hence its inability to take more than four steps at a time.

Despite the robot's shortcomings, its functionality was still impressive given that it was conceptualized, designed, and built within 8 months with limited budget and manpower. During the Cornell Cup USA competition at Walt Disney World, the robot was able to demonstrate its walking capability and impress the audience.

In the future years, the team could further develop the walking mechanism by adding more degrees of freedom and improving its gait. This year's robot was a successful first iteration of a humanoid walking robot design.

# 11 Appendix

## 11.1 Motor Specifications

Model Number:

### MMP D33-655B-24V GP81-025

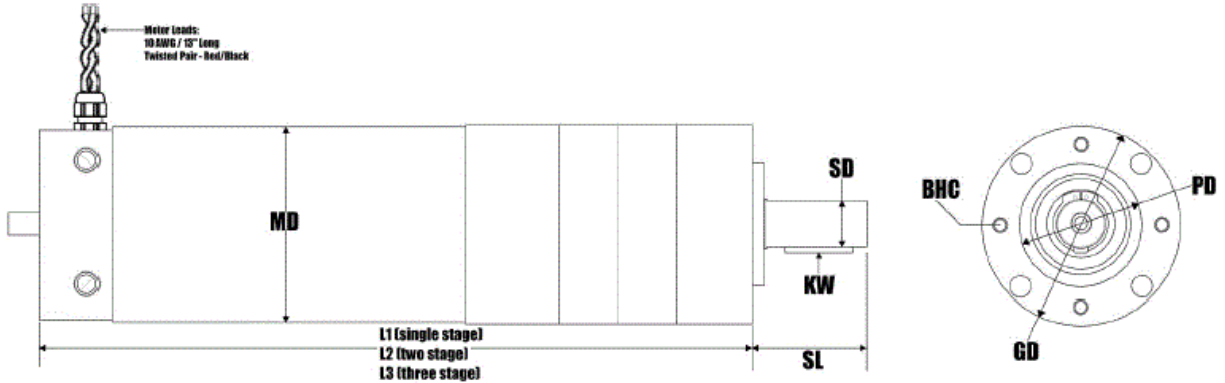

**DIMENSIONS:** NOTE: OPTICAL ENCODER & INTEGRAL BRAKE OPTIONS AVAILABLE - SEE ADDITIONAL PAGES FOR DETAILS

MD = 3.13" (80mm)	SL = 49mm (40mm usable)	Note: Center of output shaft contains an M-6 threaded hole
GD = 3.20" (81mm)	SD = 0.748" (19mm); +0, -21µm	BHC (dia) = 65mmØ (4 ea) M6x12mm deep
L2 = 11.25" (286mm)	KW = 3mm(H) x 6mm(W) x 28mm(L)	PD = 50mm, pilot length = 5mm

PLANETARY GEARMOTOR OUTPUT PARAMETERS:	VALUE	UNITS	TOLERANCE
Gearhead Ratio (exact)	25.01 : 1		
Gearhead Shaft Output Speed (at full-load)	160	RPM	MAX
Gearmotor Rated Continuous Torque	202	In-Lbs	MAX
Gearmotor Rated Peak Torque	1062++	In-Lbs	-----
Gearhead Standard Backlash	33	Arc Minutes	MAX
Gearhead Efficiency	75%	-----	-----
Output Shaft Radial Load Capacity	135	Lbs	MAX
Output Shaft Axial Load Capacity	27	Lbs	MAX
Gearmotor Total Weight	14.3	Lbs	MAX

++ All Peak Torque values are dependent upon duty. Contact our sales office for details.

DC MOTOR PERFORMANCE PARAMETERS:	VALUE	UNITS	TOLERANCE
Rated DC Voltage	24	DC VOLTS	-----
Rated Continuous Current	23.9	AMPERES	-----
No-Load Speed	4530	RPM	MAX
Rated Speed	4000	RPM	+/- 15%
Rated Continuous Power Out	509	WATTS	+/- 15%
Rated Continuous Torque	172	OZ-IN	-----
Peak Torque (motor only)	1250	OZ-IN	-----
No-Load Current	1.11	AMPERES	MAX
Back EMF Constant (Ke)	5.3	V/KRPM	+/- 10%
Torque Constant (Kt)	7.2	OZ-IN/AMP	+/- 10%
DC Armature Resistance	0.14	OHMS	+/- 15%
Armature Inductance	0.09	mH	+/- 15%
Armature temperature	155	DEG. C	MAX

**Option1: Optical Encoder Option**

Contact sales for pricing

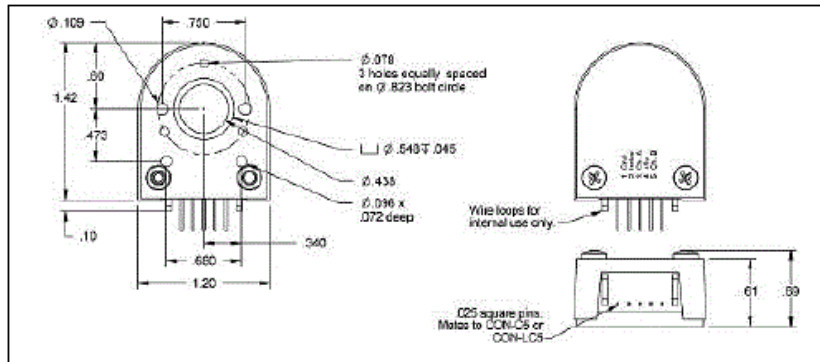

EU Series Interconnects/Functions		
Pin #:	Function:	Color:
1	Ground	Brown
2	Index	Violet
3	Channel A	Blue
4	+5 Volts	Orange
5	Channel B	Yellow

\*Resolutions available from stock: 32 PPR, 100 PPR, 250 PPR, 500 PPR, 1024 PPR  
 (Use suffix "EU-xxx" after model # to designate resolution)  
 Encoder is mounted integrally to the back of the motor or brake.  
 Includes an index pulse, and 12" long flying leads.

**Option 3: Integral Brake Option**

Contact sales for pricing

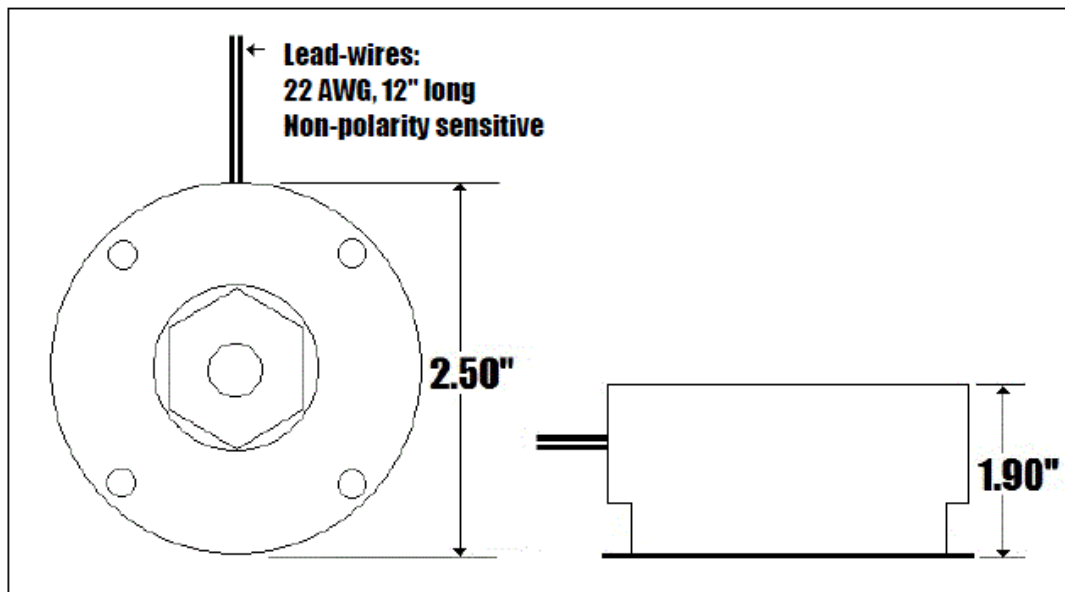

The MMP mid frame gearmotors and motors are sufficiently served by a 15 in-lb brake, when used correctly.  
 Typical (24v) brake current = 400 mA;  
 All brakes (12v, 24v, 36v, 48v & 90v) are 9.6 Watt devices

## 11.2 Citations

"Robotics/Types of Robots/Walkers." *Wikibooks*. N.p., 31 Aug. 2012. Web. 7 Dec. 2013.  
<[http://en.wikibooks.org/wiki/Robotics/Types\\_of\\_Robots/Walkers](http://en.wikibooks.org/wiki/Robotics/Types_of_Robots/Walkers)>.

"History of Honda's Robot Development." *Honda Worldwide Site*. N.p., 2013. Web. 16 Oct. 2013.  
<[http://world.honda.com/ASIMO/history/e1\\_e2\\_e3/index.html](http://world.honda.com/ASIMO/history/e1_e2_e3/index.html)>.

Honda Belgian Branch. "Honda ASIMO Demonstration." *YouTube*. YouTube, 20 Feb. 2013. Web. 16 Oct. 2013. <<http://www.youtube.com/watch?v=xt090WrKU3w>>.

Ackerman, Evan. "Honda Robotics Unveils Next-Generation ASIMO Robot." *IEEE Spectrum*. N.p., 8 Nov. 2011. Web. 20 Oct. 2013. <<http://spectrum.ieee.org/automaton/robotics/humanoids/honda-robotics-unveils-next-generation-asimo-robot>>.

"Nao (robot)." *Wikipedia*. Wikimedia Foundation, 12 Dec. 2013. Web. 15 Dec. 2013.  
<[http://en.wikipedia.org/wiki/Nao\\_\(robot\)](http://en.wikipedia.org/wiki/Nao_(robot))>.

"Aldebaran Robotics NAO Specifications." *Aldebaran Community Website*. N.p., 2013. Web. 15 Dec. 2013. <<https://community.aldebaran-robotics.com/nao>>.

BotSportTV. "RoboCup 2013 Adult Size FINAL: TAIWAN / JAPAN." *YouTube*. YouTube, 01 July 2013. Web. 20 Oct. 2013. <<http://www.youtube.com/watch?v=xqWELifR2P0>>.