

# Master of Engineering Final Report

Dynamic Analysis of a Sanderson Rocker Arm Mechanism

Advisor: Professor John F. Booker

Christopher Graham

14 May 2014

## Abstract

This paper details the rigid-body dynamic analysis of a Sanderson Rocker Arm Mechanism (S-RAM). The analysis was performed using numerical methods through the rigid-body dynamics module in ANSYS, and is intended to allow the verification of an analytical solution developed by Professor John Booker. For the purpose of this comparison, various results are presented for the special case of constant crankshaft angular velocity with no cylinder pressure. However, the model may easily be extended to more general cases if necessary.

## Introduction

The S-RAM drive is an alternative to the slider crank mechanism used in most internal combustion engines to convert the reciprocating rectilinear motion of the pistons into rotation of the output shaft. Alternatively, it can do the reverse, as in a pumping application. It offers several distinct advantages over a slider crank. For instance, it allows variation of the piston stroke during operation by altering the crank throw; furthermore, with single-ended pistons, this can be done in such a way as to maintain constant head clearance. It also exerts negligible side forces on the cylinder walls, reducing friction and wear.

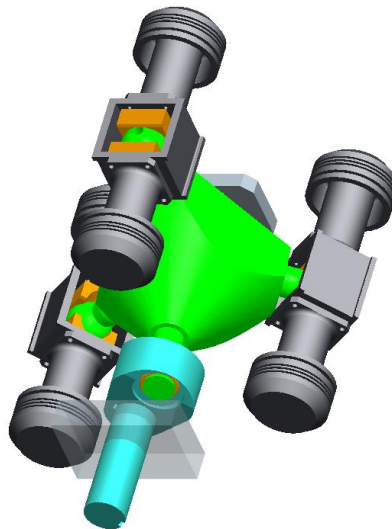

*Figure 1: SRAM solid model*

S-RAM drives can be used in many different configurations, with any number of single or double-ended pistons. This particular analysis is based on a solid model provided by Professor Booker, shown in figure 1. It has three double-ended pistons arranged at equal spacing around the output shaft, and the crank throw is fixed. This model is not a practical mechanism, but it has all of the fundamental components and is representative insofar as rigid dynamics are concerned.

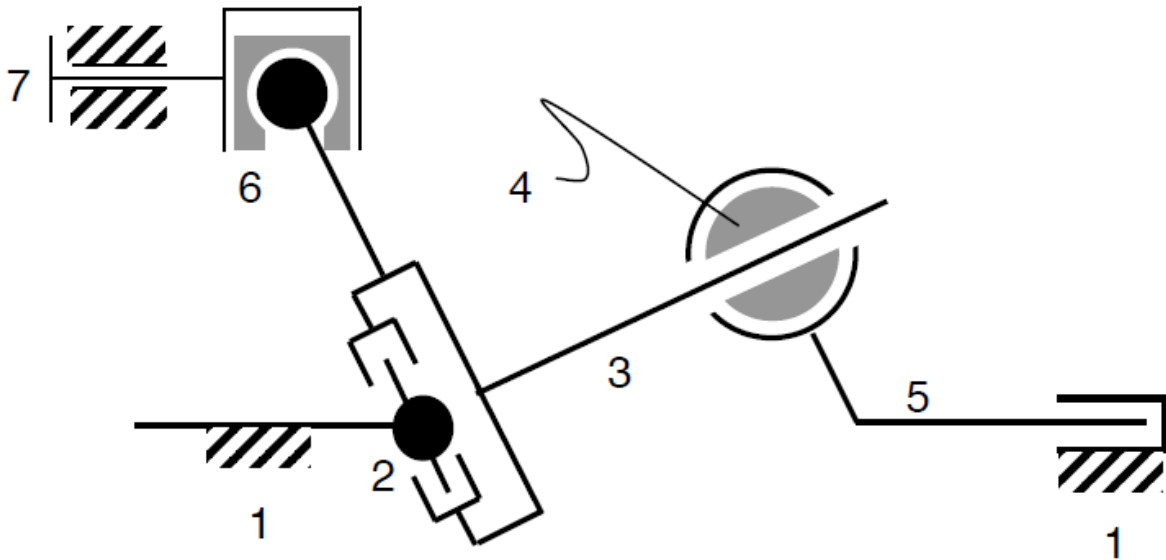

Figure 2: Mechanism schematic

The centerpiece of the mechanism is the rocker (body 3). The rocker is constrained by a universal joint (the cross of which is body 2) to a fixed base (body 1), leaving two angular degrees of freedom. Those are constrained by the crankshaft (body 5) by way of a cylindrical bearing that allows axial plunge. The crankshaft is itself constrained by a bearing set such that it only has a single rotational degree of freedom. Thus, crankshaft angle fully determines the position of both the crankshaft and the rocker. To avoid over-constraint, the cylindrical bearing between the two bodies is mounted in a spherical sleeve (body 4); this introduces an unconstrained rotational degree of freedom of the sleeve about its axis of symmetry, which has no meaningful effect on the results but should be kept in mind when counting degrees of freedom for the system.

As the crankshaft rotates, the three spherical bearings around the periphery of the rocker undergo a complex three-dimensional motion. Their translation, but not their rotation, is transmitted to the pads in which they sit (body 6). These pads, in turn, transmit to the pistons (body 7) only the component of their translation that is directed along the piston axis. Thus, neglecting friction as the pads slide from side-to-side, they exert no side forces on the pistons, and so the pistons exert no side force on the cylinder walls. The mechanism as shown in figure 1 does not constrain the rotation of the pads around the piston axis; this is artificially constrained in the analysis, with no effect on the results. A practical mechanism would constrain the pads.

The complexity in analyzing the mechanism's rigid dynamics arises mostly from the universal joint used to constrain the rocker. The motions of the pistons are nearly sinusoidal for small rocker tilt angles, but the higher harmonics become more significant the more the rocker is tilted. This added complexity makes it useful to verify the analytical calculations with numerical methods.

## Analysis setup

The rigid-body dynamics module in ANSYS Workbench allows an analysis to be performed in a relatively straightforward fashion through a graphic interface, using a solid model of the mechanism. Various

types of joints can be applied to constrain the degrees of freedom between the parts in the assembly. These joints act on Cartesian frames used to represent the bodies, so care must be taken to ensure that these frames are located and oriented properly. For instance, they must be at the center of the sphere for a spherical joint, which is often not the case by default.

Some attention to coordinate systems is also required when reporting results. Force and moment probes at the joints are always reported in terms of the coordinate systems used to define the joints, which move during simulation. However, those same coordinate systems do not move when they are used to report any results other than the loads associated with that joint. Unfortunately, other coordinate systems defined by geometry references also do not move with their respective bodies during simulation. This makes it necessary to report kinematic results in the fixed frame, while the choice of frame to report joint loads is limited to those of either body participating in the joint.

With exception of these issues, setting up the simulation is straightforward. ANSYS is also very forgiving when it comes to redundant constraints. While the model in this analysis is minimally constrained, ANSYS seemed to have no issues solving for an over-constrained model, although the constraint forces for those degrees of freedom would presumably be suspect.

## Operating conditions

The simulation was run under the following conditions:

Crankshaft speed  $\omega_{5/1} = 100 \text{ rad/s}$

Angular acceleration  $\alpha_{5/1} = 0 \text{ rad/s}^2$

Cylinder pressures  $p = 0 \text{ Pa}$

Refer to the appendix for the model parameters.

## Results

While the following plots do not cover all of the dynamics of interest, they suffice to compare the two analyses. Refer to the appendix for the coordinate systems used.

### Kinematic plots

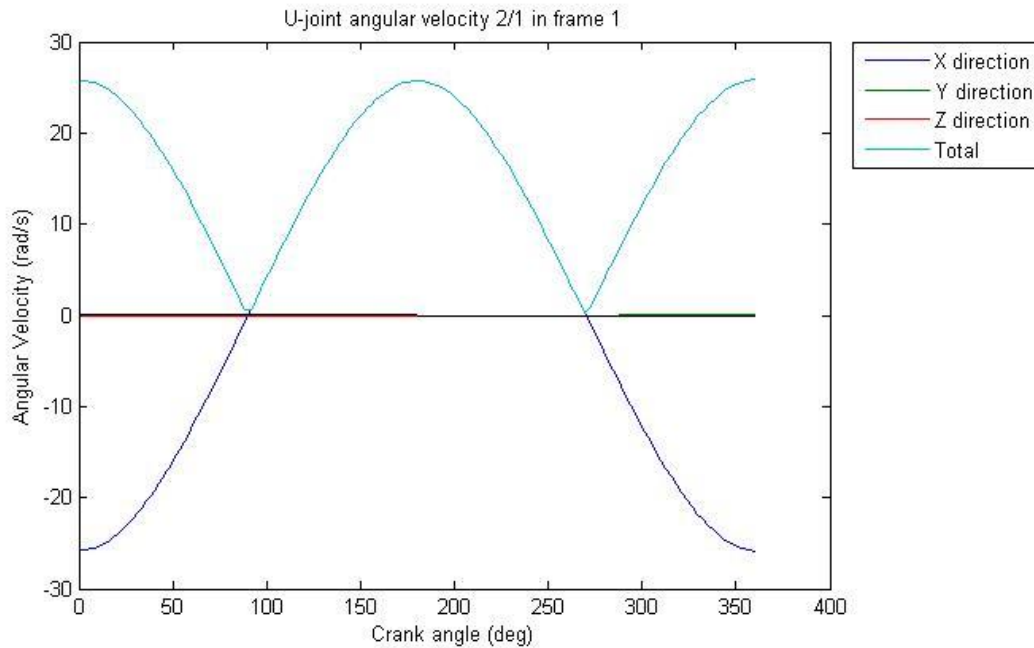

Figure 3

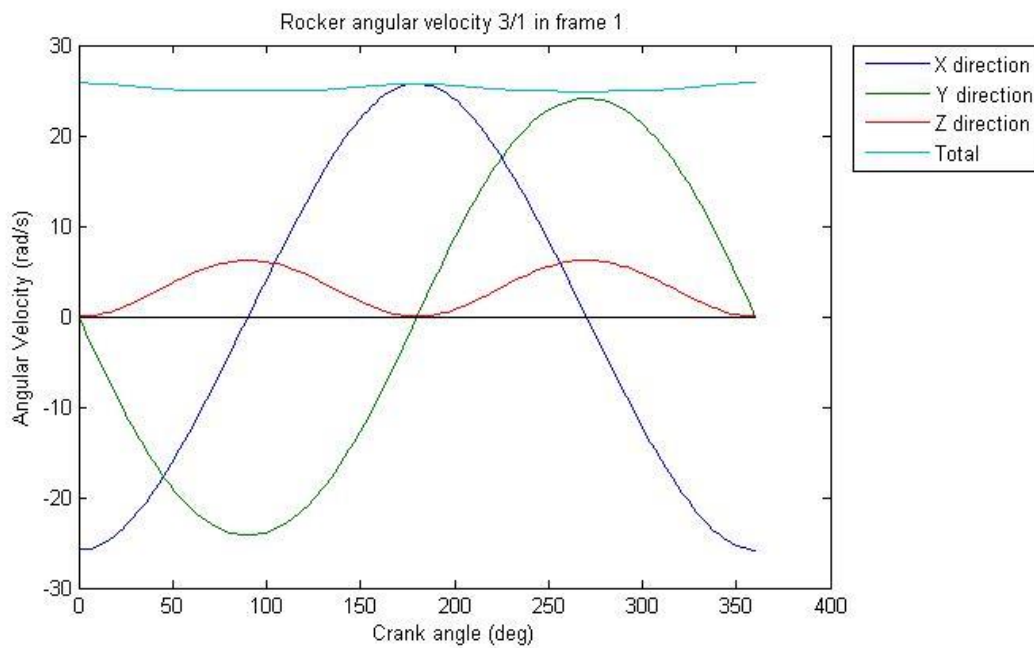

Figure 4

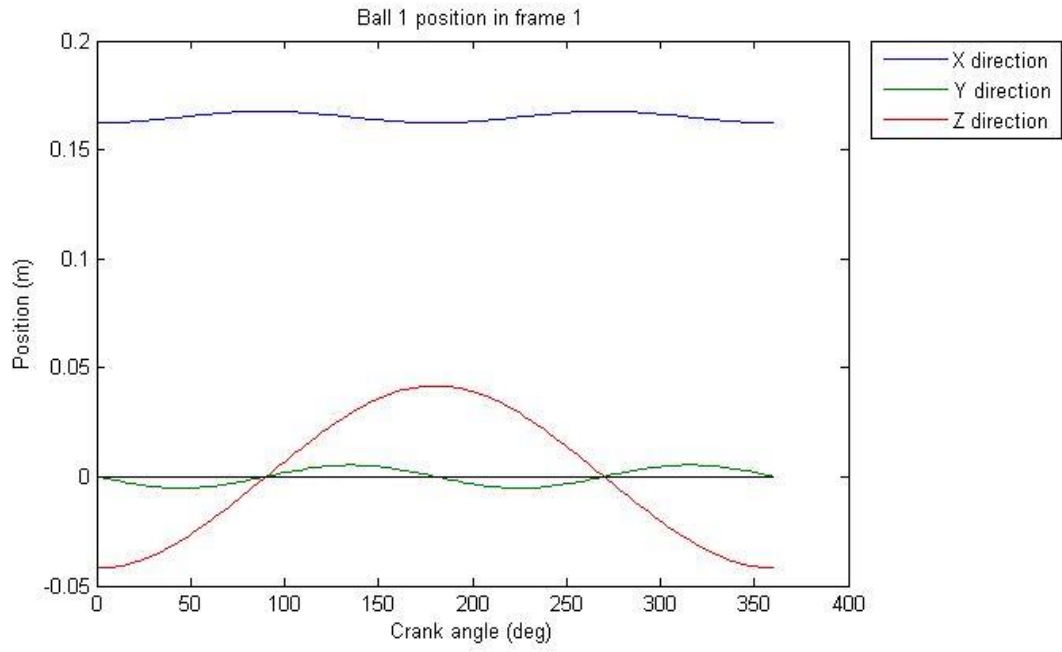

Figure 5

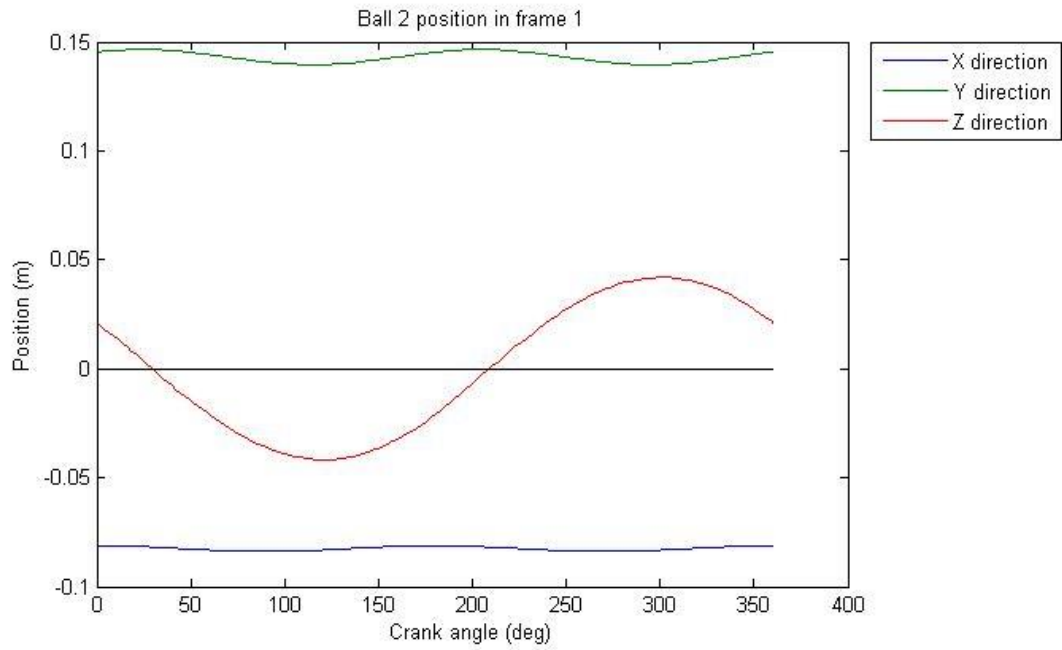

Figure 6

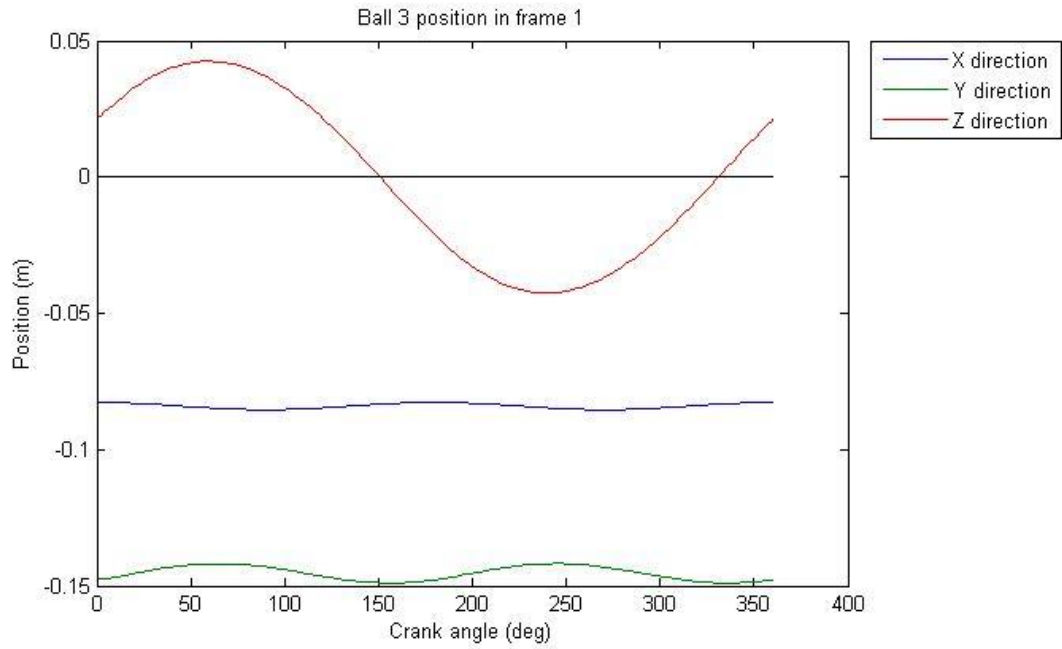

Figure 7

### Load plots

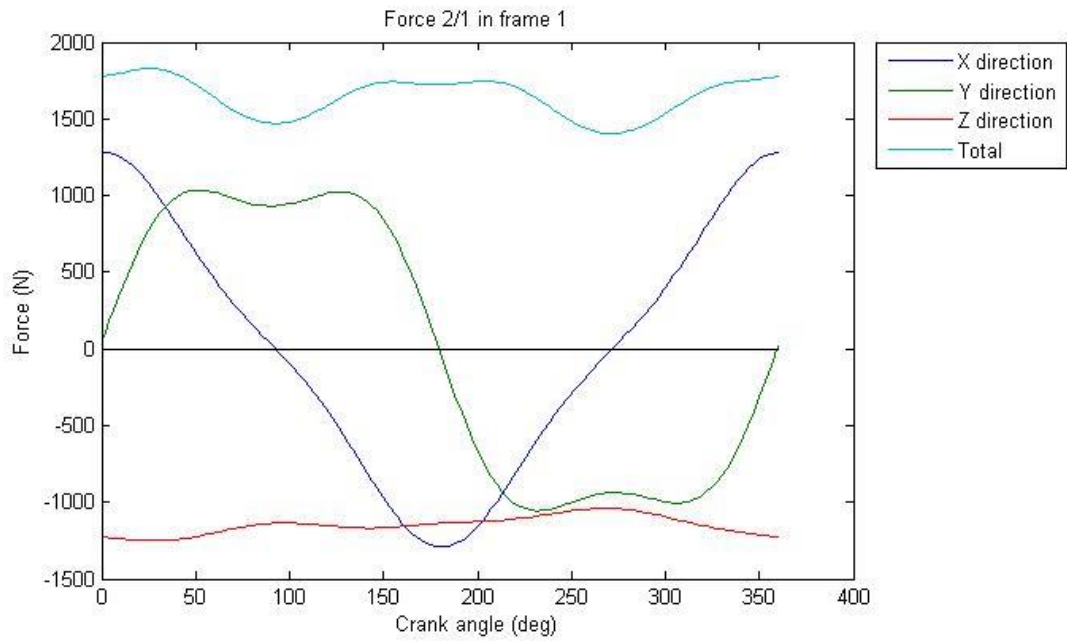

Figure 8

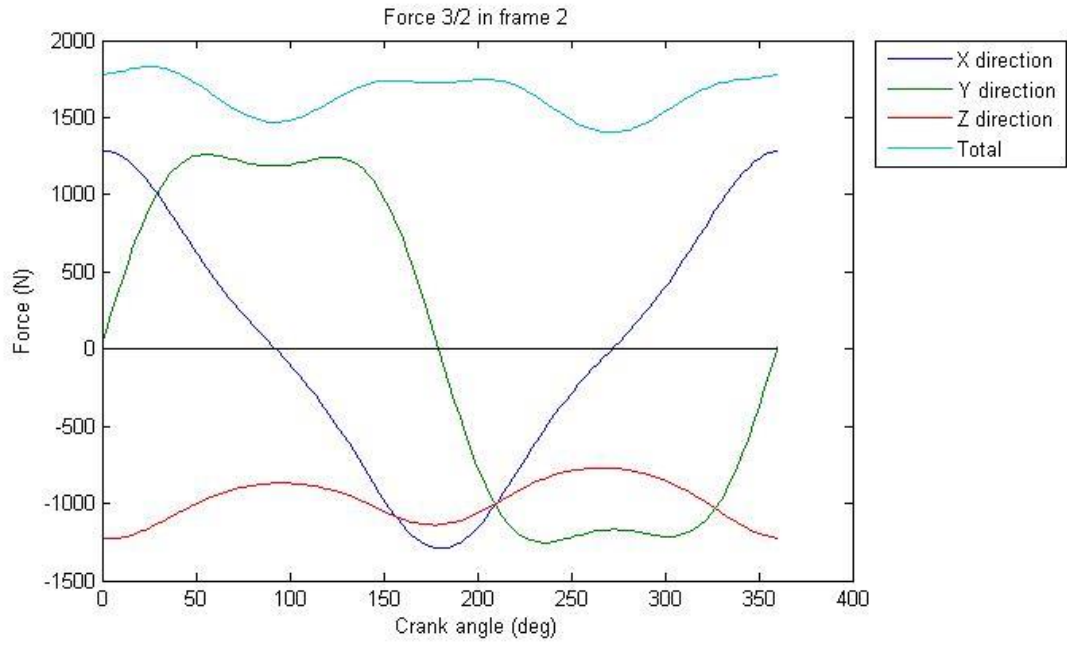

Figure 9

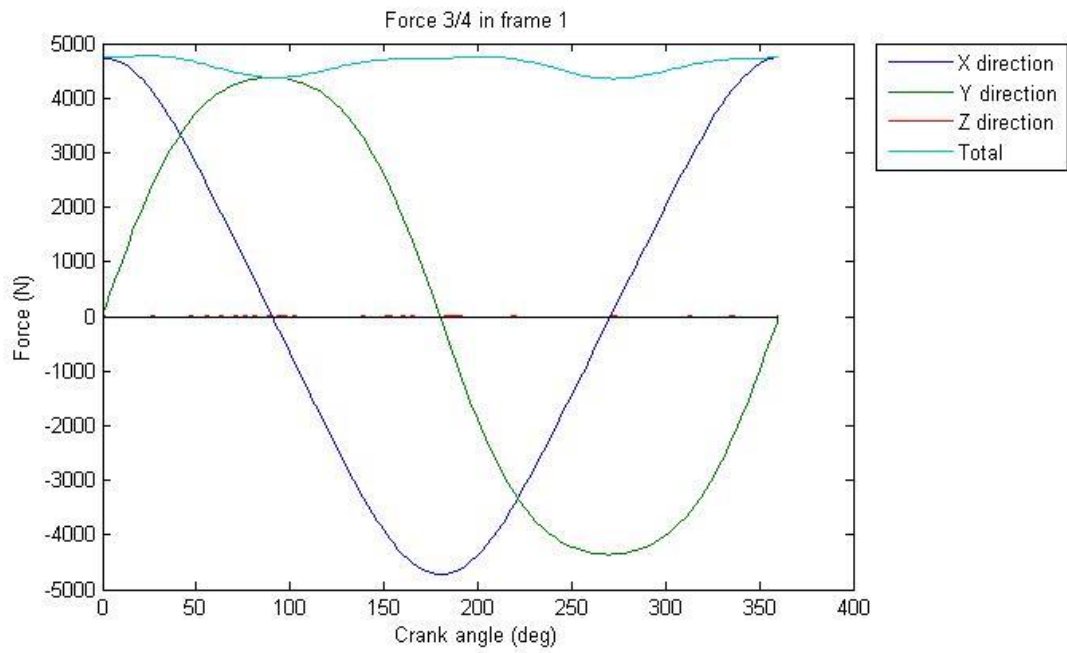

Figure 10



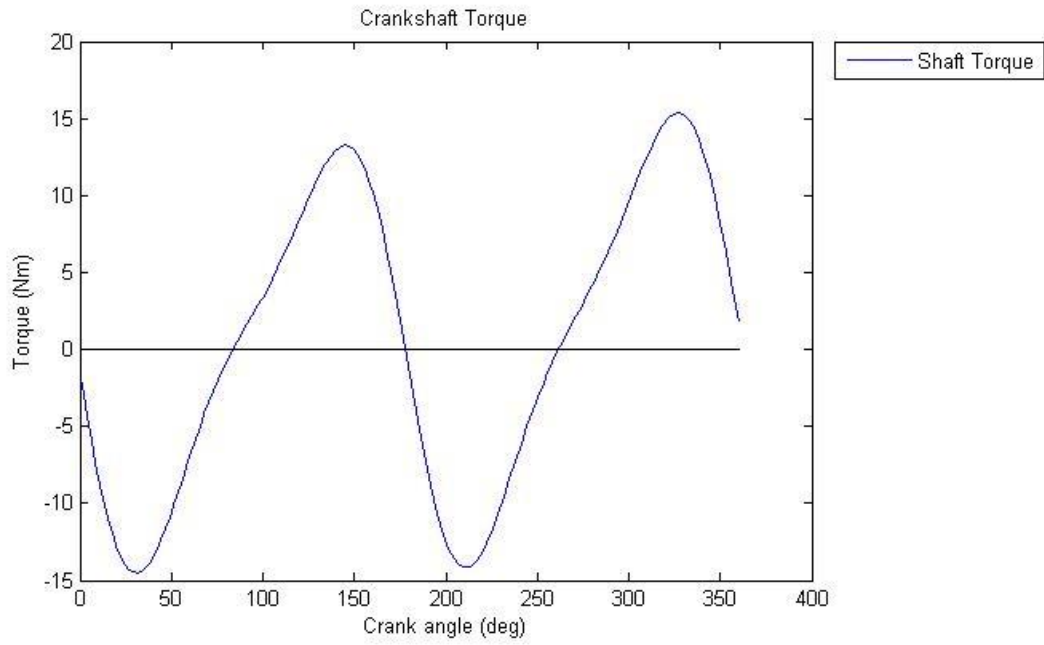

Figure 11

## Appendix

### Coordinate systems

The following schematic shows the coordinate systems used to present the results.

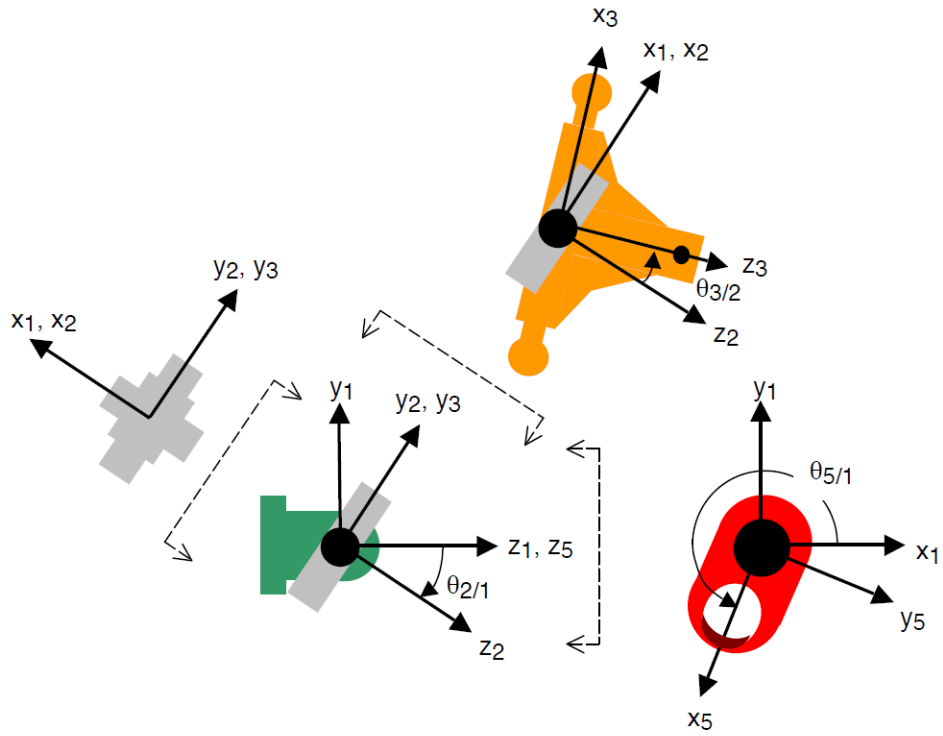

Figure A1: Coordinate systems

## System parameters

### Dimensional Properties:

$$B = 0.213727 \text{ m}$$

$$L = 0.220729 \text{ m}$$

$$R = 0.0551434 \text{ m}$$

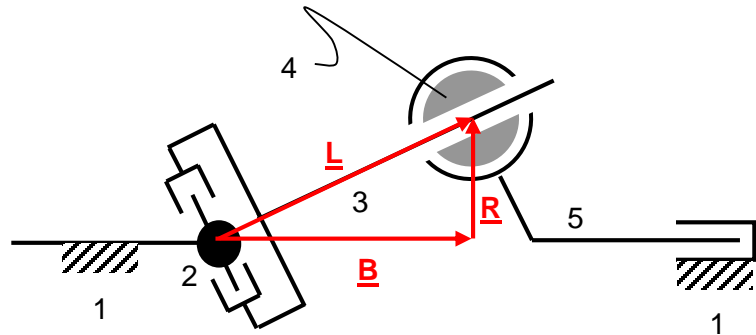

Figure A2

$$\text{Piston diameter} = 0.103188 \text{ m}$$

$$\text{Piston axis radius} = 0.164084 \text{ m}$$

$$\text{Ball diameter} = 0.0571500 \text{ m}$$

$$\text{Rocker ball position radius} = 0.166827 \text{ m}$$

Ball positions:  $0, 2\pi/3, 4\pi/3$  rad

U-joint bearing center position components:

In x direction:  $\pm 0.01905 \text{ m}$

In y direction:  $\pm 0.0348615 \text{ m}$

**All inertia properties were found using the default densities in ANSYS:**

Steel:  $7850 \text{ kg/m}^3$

Aluminum:  $2770 \text{ kg/m}^3$

Brass:  $8300 \text{ kg/m}^3$

U-joint cross (steel):  $m = 0.57853149 \text{ kg}$

$$I = \begin{bmatrix} 3.1922507\text{e-}04 & 0.0000000\text{e+}00 & 0.0000000\text{e+}00 \\ 0.0000000\text{e+}00 & 9.7781279\text{e-}05 & 0.0000000\text{e+}00 \\ 0.0000000\text{e+}00 & 0.0000000\text{e+}00 & 3.4408056\text{e-}04 \end{bmatrix} \text{ kg}\cdot\text{m}^2$$

Position of COM w.r.t frame 2:  $(0, 0, 0) \text{ m}$

Rocker (steel):  $m = 32.391985$  kg

$$I = \begin{bmatrix} 2.3359453e-01 & -5.8845048e-04 & 7.5269393e-05 \\ -5.8845048e-04 & 2.3276211e-01 & 1.3029198e-04 \\ 7.5269393e-05 & 1.3029198e-04 & 2.0967208e-01 \end{bmatrix} \text{ kg}\cdot\text{m}^2$$

Position of COM w.r.t frame 3:  $(-2.8245659e-04, -4.8916149e-04, 4.0952223e-02)$  m

Crank shaft assembly, including spherical bearing and sleeve (sleeve is brass):

$m = 5.9345911$  kg

$$I = \begin{bmatrix} 4.0590434e-01 & 0.0000000e+00 & -1.8702433e-02 \\ 0.0000000e+00 & 4.0947537e-01 & -5.3858463e-05 \\ -1.8702433e-02 & -5.3858463e-05 & 9.5516210e-03 \end{bmatrix} \text{ kg}\cdot\text{m}^2$$

Position of COM w.r.t frame 5:  $(1.4881654e-02, 2.3210388e-06, 2.5405855e-01)$  m

Ball seat (steel, mass per set of two):  $m = 0.89126053$  kg

Pistons (aluminum, mass per set of two):  $m = 1.45461524$  kg

Piston carrier (steel):  $m = 1.7830128$  kg