

PRODUCT LIFECYCLE MANAGEMENT (PLM) FOR THE CORNELL FSAE TEAM

Master of Engineering Project 2014

Shuran Cheng (sc2568)

05/10/2014

Table of Contents

1	Introduction	4
2	Importance of PLM Implementation	4
3	History and Current Process of PLM tools	5
3.1.1	Windchill	5
•	PTC Sponsorship	5
•	Server Issues, IT Issues	6
•	Realized Limited Functionality	6
3.1.2	Autodesk Software	6
3.2	Current Process For Cornell FSAE Team	7
3.3	Current Process For Other FSAE Team	8
4	Evaluation for the PLM Tools	8
4.1	Criteria for Evaluation	8
4.2	Tools Used for Evaluation	9
4.2.1	Originating Requirements	9
4.2.2	Characteristics Comparisons	10
4.2.3	Decision Matrix	11
4.2.4	Focus Category	12
4.2.5		13
5	Comparison of PLM Tools Based on Testing	13
5.1	Get Started	13
5.1.1	Windchill	13
5.1.2	Workgroup PDM	13
5.1.3	Autodesk PLM 360 & Arena	14
5.2	Time Testing	14
5.3	CAD Model Management & Control	16
5.3.1	Windchill	16
5.3.2	Workgroup PDM	18
5.4	Timeline	19
5.4.1	PLM 360	19
5.4.2	Arena	19
5.4.3	Google Doc	20
5.5	Change Control	21
5.5.1	PLM360	21
5.5.2	Arena	22
5.5.3	Windchill	23
5.6	Meetings Records	24
5.6.1	Windchill	24
5.6.2	Other tools	25
5.7	History	25
5.8	PTC Integrity and Traceability Matrix	27
6	Conclusion and Recommendations	28

Table of Figures

Table 1 Originating Requirements for Evaluation.....	10
Table 2 Characteristics Comparisons of possible options	10
Table 3 Decision Matrix for Evaluation	12
Table 4 Criteria for Decision Matrix	12
Table 5 Categories for tested software.....	13
Table 6 Time needed for models in with different size	15
Figure 1 Distribution of CAD model size.....	14
Figure 2 Structure of Workgroup PDM	15
Figure 3 Structure of Autodesk Vault.....	16
Figure 4 View CAD models in Windchill	17
Figure 5 Revision history of CAD models in Windchill	17
Figure 6 CAD mangement in Workgroup PDM.....	18
Figure 7 Review history in Workgroup PDM.....	18
Figure 8 Timeline in Autodeak PLM 360.....	19
Figure 9 Timeline setting in Arena	20
Figure 10 Timeline in Arena.....	20
Figure 11 Timeline in Google Doc	21
Figure 12 Task list in Google Doc.....	21
Figure 13 Change control in PLM 360	22
Figure 14 Chang control workflow in PLM 360	22
Figure 15 Change control in Arena.....	23
Figure 16 Change control workflow in Arena	23
Figure 18 Meeting record in Windchill	25
Figure 19 Meeting record in Arena.....	25
Figure 20 History record in PLM 360.....	26
Figure 21 History record in Google Doc	27
Figure 22 Homepage of the Traceability Matrix	28
Figure 23 Customer Requirement vs System Level Requirement page	28
Figure 24 System Level Requirement page	28

1 Introduction

Product lifecycle management is the process of managing the entire lifecycle of a product from inception, through engineering design and manufacture, to service and disposal of manufactured products. PLM (Product Lifecycle Management) integrates people, data, processes and business systems and provides a product information backbone for companies and their extended enterprise. It has been a long time that the Cornell FSAE Team has been seeking PLM tools, which would allow for better organizing and control of the CAD models, data and timelines. Since most successful PLM software is developed for large companies in engineering related fields, it is necessary to compare some possible options and their features to decide if any of them fits for smaller organizations like the FSAE Team.

This project evaluated several tools, both the ones we are currently using and those we tried to put into implementation. “Tools” is used instead of “Software” for the reason that some of the options, such as S-Drive and Google Doc, are not professional software. Methods for system engineering analysis are applied for the purpose of evaluation. From the perspective of the team, there are several critical functions for both project management and CAD management, which were compared with different tools. At the end of the project, some suggestions are given for further research.

2 Importance of PLM Implementation

To elaborate the reason why the FSAE team needs a PLM tool throughout the project, some problems the team faces and corresponding advantages of a PLM system should be listed to show how the tools might solve those problems.

Some problems about product lifecycle management in the team:

- An advanced timeline with milestones and the ability to keep track of the process of each sub project and individual tasks in order to organize things that are needed to be done;
- Errors or confusions may appear among CAD models because of poor CAD file management. No history record and check in/out function leads to mistakes when many people are revising the same model;
- Without the BOMs (Bill of Materials) generation, it will take much more time on cost report;

The advantages of PLM implementation for Cornell FSAE Team:

- Better designed project management settings for the team to schedule upcoming plans and verify the processes of certain tasks. The team has used Google Doc for several years, though it is convenient and powerful from some respects, it would

- definitely be better to pursue an well-designed professional project management tool;
- The ability to share data within the team in a faster and easier way, which increases the efficiency through concurrent engineering. People can work simultaneously on the same data or models and any changes made by the team members are recorded and can be shown to everyone;
 - A record of all the parts and components with their detailed information such as number, materials, price and relationships with other parts to form the BOMs, which makes it easier to create change controls and build cost report;
 - Keeps track of the orders and cost of the racecar to deliver a high quality product delivered on time and within budget constraints. Also helps with the cost report;
 - Records the process of design reviews. Each designed part would be tracked from preliminary design review to final design review;
 - The ability to set different roles, critical documents or processes need the approval of advisors or team leaders. That may help the whole team to clarify which stage the project is in;
 - Huge amount of email can be avoided with the platform provided by PLM tools. Members are able to conduct shared information and discussion within the assigned part and give comments at any stage of certain task. Emails can be sent automatically to responsible people when needed (milestone deadline or changes made by others).

3 History and Current Process of PLM tools

3.1. History

3.1.1 Windchill

- **PTC Sponsorship**

“One of the major projects for 2010-2011 was to return to the possibility of supplementing the team’s document management with Project Lifecycle Management (PLM) software. Earl Manzano outlined the use of various software packages back in 2005 for his MEng project, but there was no feasible option for PLM software that was able to improve the FSAE team. The PTC sponsorship with WPP allowed us to further pursue this option. WPP (Windchill ProductPoint , one of their PLM software systems, MathCAD, e- learning licenses, and the Expert Framework Extension (EFX) for Pro/Engineer) is considered a collaborative PLM tool. This means that it intends to incorporate a high level of social interaction into the design. It is built on top of Microsoft Sharepoint, which has the same type of capability, but for more general documents such as those created in Microsoft Office. WPP takes this capability and adds on top of it the ability to add onto it an interface to save CAD documents.” (Domanti, Sawasdirak, 10-11)^[1]

- **Server Issues, IT Issues**

“Originally, we had a server that could be upgraded to be capable of hosting WPP. This is the PTS Server (Project Team Server) that was originally purchased by Professor George a few years back. It is meant to host data for all project teams, but really did not get much use. FSAE used to use the server to host the wiki, which has since been moved to confluence. There are also some traces of bugzilla being used. The server originally had 2 GB of memory, but 4GB were needed to host WPP. There were early discussions as whether to purchase a new server or to upgrade the old one. It made the most sense to purchase a new server if the team was planning to continue with WPP in the future. Since, we are just trying out the software and not committed to using it in the future, it made most sense to upgrade the existing server’s memory, which was 1/10th the price of a new server. We unfortunately were not able to use WPP to its full capability. Due to issues with software upgrades in the department, we had very limited functionality of the system. We were able to set up the software and access it through a web browser but were not able to get Pro/Engineer working with it. This was largely due to the M&AE department. We had access to the server to host WPP, but the individual computers in each of the labs did not have the clients installed...There were 3 computers in the design studio (against the wall) that did have Wildfire 5 installed late in the semester. This confirmed compatibility between WPP and Pro/Engineer on the MAE network. The original plan was to then have everyone save their parts to WPP on these computers and on the S drive. After finding out that Wildfire 4 cannot open Wildfire 5 files, this idea was abandoned. We eventually gave up on building the CAD model using WPP this semester once design got far enough that the full assembly was being put together. ” (Domanti, Sawasdirak, 10-11)^[1]

- **Realized Limited Functionality**

“The functionality we did have worked out well. Everyone was given an account and asked to update their profiles. The users screen was then laid out to see everyone’s name, phone number and role on the team. We created a documents library within the 2011 section of the site and used this as a spot to post all items related to design reviews. This worked out well as it grouped everything together and allowed a common place for the leaders to find them. The documents can also be edited and reposted. We did this with the first round of forms to make sure everyone was on the right track. We also used the built in task list. The advantages are that when you create a task, it has a spot for all the information and emails the person who it is assigned to. They can be organized in a variety of ways and a report can be run and exported to excel. The disadvantages are that they must be checked regularly with reminder emails sent regularly, and the site can only be accessed on campus. Since this was the fall and there were not too many tasks other than design, we stopped using this feature. Once we are in the midst of the spring and tasks are more abundant, I think this feature would be much more useful.” (Domanti, Sawasdirak, 10-11)^[1]

3.1.2 Autodesk Software

“Earlier in Fall 2010 semester, Sweet, Neil and Chris Domanti met with some Autodesk people. This was very informative as they showed us simple ways to create and analyze frame tubes, create and analyze dynamic models, render CAD items, Easily do surfacing, and mentioned a WPP type program called Vault. All this software is free to students

from the website and Cornell has 2000 seats, so it would not be hard to get it installed in lab computers. The best part is everything is integrated together. (You don't need to install the base package and then additional software on top like Pro/E). I'm not saying we should blindly switch over to this from Pro/E, but we should definitely pursue trying the software in some fashion to see if it would make design easier. A former team member who still lives in Ithaca, Joe Conway uses the software at work, says he likes it and is easy to use, and is willing to open up the model of the car in it in his office to see what benefits we can get from it. This should definitely be looked into next semester. Additionally, the 3 Autodesk guys said they are available to help us figure out how we want to use their software. They also said that if we have problems with the department not making it a priority to install the software, they would get involved and have some influence since the CEO is a Cornell Alum.” (Sawasdirak, Domanti, 10-11)^[1]

“This year we got in touch with Autodesk people again, mostly though Neil. They came on campus and gave a short presentation of their products and their capabilities. Autodesk Vault seems like a very easy to use and implement piece of software, contrary to Windchill, and might be possible to install on our old server that hosts Windchill. Moreover, a complete change out of Pro/E is not necessary, as Vault and all Autodesk products are fully compatible with pro/E files. There was supposed to be a meeting with the Autodesk people on January 16th, however because of the suspension, that might probably not happen...In any case, we should contact them, after making sure our server can handle the program, and test it out, and if it proves useful, implement it. Currently our document organization, our forms, and emails, are all messed up, since blackboard is not at all ideal for technical forms, and the S drive is not easily managed. From the limited experience we have had with the Vault program, it seems that it will prove useful, as it integrates with Microsoft office for easy document submission, also sends automated email about model updates, deadlines, schedules, etc. ” (Vilaetis '12)^[1]

3.2 Current Process For Cornell FSAE Team

S-Drive and Google Doc are still used as main tools for our present PLM system to schedule plans and tasks and store data and files. Due to limited functions they have, problems mentioned above appeared and lead to waste of money and time. For the professional software we tested several potential options fit for small to medium organizations: Windchill, Autodesk PLM 360, Soliworks PDM Workgroups and Arena. Windchil and Autodesk are willing to provide a sponsorship and to help the team with some of our specific problems. Solidworks sponsored free student version to the team, but without the PDM Workgroups included. Detailed results of the tests will be given in the later part of this report. Due to server issues and limited time for the whole team to move to new software, none of them were put into use during this semester. PTC Integrity became another option at the end of the semester and we will take a look at it. Erich Leonard, an alumnus who is currently a manager in New York Air Brake, provided excellent Excel-based Requirements Traceability Matrix for existing products. Since it focuses only on the finishing products, not the whole product lifecycle, we won't compare it with other tools in evaluation methods but will definitely present evaluation of the matrix.

3.3 Current Process For Other FSAE Team

Besides Cornell FSAE Team, other teams also try to solve similar problems with professional PLM software. Some teams have successfully taken PLM software into implement, such as Auburn University, who is supported by Siemens and Colorado State University, who uses PTC software for CAD models and PLM. On the other hand, according to the discussion in FSAE Forum, many teams are trying different tools to find one best for their teams. Teams that look for better solutions currently use other choices like Drop box and SVN while other professional options are discussed and suggested.

4 Evaluation for the PLM Tools

4.1 Criteria for Evaluation

The various PLM tools were evaluated on the basis of different criteria of relevance to the Cornell FSAE team and more generally, for small organizations without a large IT support team who want to implement PLM in their organization. According to the need of team, some of these were:

Feasibility of Installation: This refers to the ease of installation of the software by a small organization without a dedicated IT team to support the installation process and more specifically, by the Cornell FSAE team. Based on this criterion, a small team would benefit from installing a cloud-based solution like Autodesk PLM 360 as it provides, at present, a free 30-day trial for its most basic version. (Sanyukta Das '13)^[1]

It is unrealistic to require everyone to install some large software on their own laptop, and also not easy to install it on lab computers. It needs space and maintenance to keep the software on lab computers and the use of it would be limited. Web-based software saves more time in respect of installation. Though we cannot have own server if we use a cloud-based software, but it doesn't really matter since we are not very concerned about company/team security.

Ease of Use and Maintenance: This is an especially critical criterion as it determines the adoption of the solution by the team. The harder it is for team members to learn and use the software and the more tedious is its maintenance, the less is the probability that it will be adopted widely by the team. Some factors like the use of a database, availability of training resources, etc. make the adoption process harder. Based on this criterion, PTC Windchill PDM Link was eliminated, as it required us to use an Oracle database, which wasn't feasible for the FSAE team. (Sanyukta Das '13)^[1]

Just as this previous member mentioned, the ease of use is extremely important for us to make a choice. It may take some time for the system engineers to build up everything such as import CAD models and set permissions, but what is required is the software is easy for each member to learn and use. If most students regard the software as a tough tool, it will be impossible to utilize it.

Functions Provided: The solutions were also evaluated on the basis of the different function the software could perform such as change management, project management tasks, checking out of items etc. These functions are discussed in detail later. (Sanyukta Das '13)^[1]

The main consideration when evaluate the tools includes several functions: efficient project management settings, change control and meeting record and BOMs. Also the ability to store files and documents is a factor. Email notification is a plus for project management.

Integration with CAD Software: This is important for an engineering team like Cornell FSAE as most of the PLM data is design based in our case. If the CAD software is integrated with the PLM software, it means that the changes made in CAD files are reflected in all instances of it in the PLM software as well and this facilitates the change management, requirements tracking and BOM generation. This part of PLM is known as Product Data Management (PDM), which uses software to track and control data related to a particular product and its design. The major dilemma faced in the project was the trade-off in PDM functions in PLM 360. While Autodesk PLM 360 is easier to use, maintain and access when compared to Autodesk Vault Pro, Vault provides the advantage of integration with not just Autodesk Inventor, but also SolidWorks and ProE, the major CAD software used by Cornell FSAE, through easily available plug-ins. Thus while PLM 360 is more about process management, Vault is more focused on PDM, which is the major requirement for the FSAE team their purpose. (Sanyukta Das '13)^[1]

This year the team use Creo for CAD, whose corresponding PDM software is Windchill. Though Windchill is the only software combining project management and CAD management and integrates with Creo and Solidworks, many complained about the complexity of it. Solidworks PDM is easier to use but we currently are not able to install it on lab computers. Vault was not tested this year, however it should be similar to Solidworks PDM.

Cost: We can hardly afford the cheapest software (Arena, according to *Top 10 Product Lifecycle Management Software Report 2013 Edition*^[2]) without sponsorship, as a result cost counts as a factor during evaluation. Both Windchill and Autodesk are willing to provide sponsorship, which is one of the reasons we spend more time trying to get familiar with this two software.

4.2 Tools Used for Evaluation

4.2.1 Originating Requirements

According the criteria for evaluation we listed the requirements we asked for the software . A methodology for system engineering was used to create the requirement list with “shall statement”, which helped to clarify what we aim to achieving by the selected software.

Table 1 Originating Requirements for Evaluation

Index	Originating Requirements	Abstract Function Name
OR.1	The software shall focus on small-medium groups	Client Focus
OR.2	The software shall keep everything after we stop using it	Safety
OR.3	The software shall give enough database storage	Storage
OR.4	The software shall function fast enough	Speed
OR.5	The software shall not be so expensive	Cheap
OR.6	The software shall be web-based or installed on lab computers	Convenience
OR.7	The software shall manage the change controls	Change Control
OR.8	The software shall keep track of design review	Design Review
OR.9	The software shall record meeting minutes	Meeting Record
OR.10	The software shall have the change history	History Track
OR.11	The documents or models shall be import to and export from the software	Import/Export
OR.12	The software shall be easy to get start and use	Ease of Use
OR.13	The software shall give different permissions to different roles	Permission

4.2.2 Characteristics Comparisons

Table 2 Characteristics Comparisons of possible options

Attributes	Workgroup PDM	PLM 360	Vault	Teamcenter Express	Arena	Google Doc	MS Project	S-Drive
Vendor	SoliWorks	Autodesk	Autodesk	Siemens	Arena Solutions	Google	Microsoft	-
In use or not	No	No	No	No	No	Yes	No	Yes
Client Focus	Small-Large	Small-Medium	Medium-Large	Small-Medium	Small-Medium	Small-Medium	Small-Large	Small-Medium
Technology model	On-premise	Cloud-based	On-premise	On-premise	Cloud-based	Web-Based	On-premise	On-premise
Compatibility of OS	Win	Win+Mac	Win	Win+Mac	Win+Mac	Win+Mac	Win	Win+Mac
Database	PDM Vault	MS SQL Server	MS SQL Server	MS SQL Server	MS SQL Server	-	MS SQL Server	-
Database Space	-	100GB	-	-	75GB/person	-	-	-
Change Management	Yes	Yes	Yes	Yes	Yes	No	Yes	No
Document Management	Yes	Yes	Yes	Yes	Yes	No	No	Yes
Project Management	No	Yes	No	No	Yes	Yes	Yes	No
CAD Management	Yes	No	Yes	Yes	Yes	No	No	Yes
Intergration with MS	Yes	No	Yes	Yes	No	Yes	Yes	Yes
BOMs	No	Yes	No	Yes	Yes	No	No	No
New Production Introduction	No	Yes	No	No	No	No	No	No
Cost	Not Sure	No	Not Sure	Yes	Yes	No	No	No

SaaS (Software as a Service) is a newly developed software delivery model in the software industry that offering Internet-based software application programs to customers through the Internet channels and networks. With the SaaS model, you can reduce up-front support costs because you no longer need to support multiple platforms and versions.^[3] Basically it can be regarded as cloud-based, the biggest difference lies in who will be in control of the database. For SaaS it is the vendor who controls all the data while for data in cloud-based software is sitting on servers that are in customers' control.^[4] In a word, different with those enterprises that may concern the security of their data, SaaS can be considered the same with cloud-based software for our team.

On-premises software is a type of software delivery model that is installed and operated from a customer's in-house server and computing infrastructure. It utilizes an organization's native computing resources and requires only a licensed or purchased copy of software from an independent software vendor.^[5] Compared with cloud-based solutions, the big disadvantages of on-premise software maybe the complexity of software installation and the great need for owner computers' sources. As a result we may give priority to cloud-based software under the same conditions.

MS SQL Server is a Microsoft cloud-ready information platform. Organizations can use SQL Server to efficiently protect, unlock, and scale the power of their data across the desktop, mobile device, datacenter, and either a private or public cloud.^[6]

The chart shows basic characteristics and fundamental features of several tools. For database space and speed, “-” stands for “not sure”. Based on the feedback of team leader, operating speed is also a factor for evaluation, however, half of options are web-based that depend heavily on Internet connection, and according to the testing experience there was no big difference between software, we didn't consider speed when make the comparisons but will mention it in the following section (5.2 Time Testing). For the cost evaluation, it is based on what it would be for our team, not the general cost. It is the same with the score in decision matrix below.

4.2.3 Decision Matrix

Decision Matrix indicates if one option meets our desired requirements of an ideal PLM tool. Only those tested this year were included in the chart. Teamcenter (by Siemens) has not been tested but another system engineer, Lei Wen, who had experience using it during his working at GM. Autodesk 360 stands out with its ease of use and maintenance and highly customizable design, while as the only non-software, Google Doc also ranks top 3 for the low threshold for use, though its scores for each attribute vary seriously. S-Drive was also considered in the Matrix. Since S-Drive has no function for PLM process, 0 was given for related attributes such as Project Management and CAD management.

Table 3 Decision Matrix for Evaluation

Attributes	Score								Weight	Final Score						
	PTC Windchill	SolidWorks PDM	Autodesk PLM 360	Arena	Google Doc	Teamcenter	S-Drive	PTC Windchill		SolidWorks PDM	Autodesk PLM 360	Arena	Google Doc	Teamcenter	S-Drive	
Reliability	4	5	4	4	4	5	5	5	10	40	50	40	40	40	50	50
Integration	5	4	3	3	2	5	2	2	8	40	32	24	24	16	40	16
Compatibility	3	4	5	5	5	5	5	5	7	21	28	35	35	35	35	35
Ease of Start	4	3	4	3	5	2	5	5	5	20	15	20	15	25	10	25
Ease of use	3	4	5	4	5	2	5	5	8	24	32	40	32	40	16	40
Operating Speed	4	5	5	4	5	2	5	5	8	32	40	40	32	40	16	40
Project Management	5	2	5	5	3	5	0	0	5	25	10	25	25	15	25	0
Change Control	4	3	5	5	1	5	0	0	5	20	15	25	25	5	25	0
Meeting Record	5	1	3	3	2	2	4	4	4	20	4	12	12	8	8	16
History	4	5	5	4	5	5	0	0	4	16	20	20	16	20	20	0
Survey	1	1	1	1	5	2	1	1	3	3	3	3	3	15	6	3
Email Notification	5	1	5	5	3	5	0	0	3	15	3	15	15	9	15	0
Cost	5	4	5	2	5	1	5	5	5	25	20	25	10	25	5	25
										301	272	324	284	293	271	250

Table 4 Criteria for Decision Matrix

Criteria	Reliability	Integration	Compatibility	Ease of Start
5	The prob of data loss is 0	The tool integrates with CAD software and data	The tool is compatible with XP/win7/win8/mac and Chrome/IE/Safari	No need to install or register
4	The prob of data loss is less than 20%	The tool integrates with CAD software	The tool is compatible with XP/win7/win8 and Chrome/IE	Need register only
3	The prob of data loss is less than 40%	The tool integrates with data	The tool is compatible with win7/win8 and IE	Need install only
2	The prob of data loss is less than 60%	The tool integrates with neither CAD software nor data	The tool is compatible with win7/win8/mac and IE/Safari	Need install and register
1	The prob of data loss is less than 80%		The tool is compatible with win7 and IE	

4.2.4 Focus Category

Last year’s report, *Product Lifecycle Management For Cornell FSAE Team* by Sanyukta Das, has a detailed illustration about the functions of Autodesk products (especially PLM 360), and it is also mentioned that we have to be clear about the different usage of them depending on their features. If we are looking for a more process driven control, we can opt for Autodesk PLM 360. However, if we need more control over data and collaboration process, it should look at Autodesk Vault as a possible solution. From this point of view, we can divide the four tools into three categories:

Table 5 Categories for tested software

	Project Management	Model Management	Project Management+ Model Management
Windchill			✓
Workgroup PDM		✓	
Arena	✓		
Autodesk PLM 360	✓		

Since we need more control of the CAD models, more attention should be paid to the model management tools. However, according to previous system analyses, both of the two are hard to start for practical use (difficult to use and requiring installation).

5 Comparison of PLM Tools Based on Testing

5.1 Get Started

The decision matrix indicates that there is no big gap among these tools, so it becomes extremely important for the software to be easy to start. Here is a summary of what we have to do for certain software. They are the most basic steps for the software to be put into use without taking any extra functions into consideration (just the easiest model management function considered).

5.1.1 Windchill

1. Invite the team members to the project;
2. Those who received the invitation need to register an account;
3. Set the permissions to different people;
4. Upload all the CAD models and needed files to Windchill.

Further steps include teaching all the members to create events and upload models. On the other hand, it will spend a huge amount of time and patience to move all the models and files to Windchill and carefully set the permissions.

5.1.2 Workgroup PDM

1. Have PDM installed in lab computers;
2. Set the permissions and accounts for team members;
3. Team members have SolidWorks as well as PDM installed in their personal computers if needed.

The tricky step may be the installation of the PDM and the decision if we are going to use SolidWorks as our CAD software in the future. For the members' convenience, they

don't need to register accounts, but if they want to use PDM in their own computers, they need to install it. We have a license series for 80 people, which is enough for the team.

5.1.3 Autodesk PLM 360 & Arena

PLM360 and Arena are pretty alike as web-based software focusing on project management process. And the steps to get started are similar as a result, we just combined these two and listed essential steps for both of them.

1. Get the accounts from Autodesk/Arena for the team;
2. Set different permissions to different people;
3. Upload all the files;
4. Import all the CAD model information (not models) to easily create BOMs;
5. For PLM 360 only: Customize the workflow to make it fit the team best (this report will give detailed analysis in a later part).

Though have many features in common, PLM 360 is regarded as the ideal process management tool compared to others compared with Arena for its more customized design for changing all the workflow and tab settings. We can seriously consider putting it into use in the future.

5.2 Time Testing

The chart shown below helps evaluate the time for Windchill/Workgroup PDM to upload or check in/out the CAD models for our racecar. The distribution of the size of the models indicates that more than half of models are between 100K-1M, and for smaller models, time spent will be less. So several models between 100K and 1M are chosen to judge the operation speed of different tools.

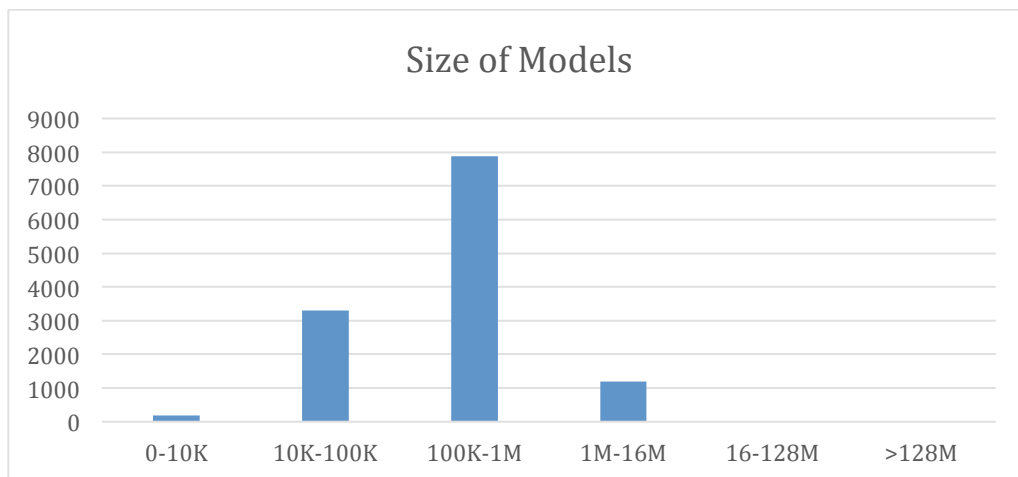

Figure 1 Distribution of CAD model size

The result is shown below. For Windchill, model should firstly be moved to workspace and then saved in web-based folders, i.e., checked in. For PDM it will be even easier --- no need to upload. For Autodesk, since we now don't have Inventor on our computer, this will be only a theoretical analysis.

Table 6 Time needed for models in with different size

Model Size	Windchill		SolidWorks PDM Check-in&out/s
	Upload/s	Check-in&out/s	
100K	<2	<2	<2
1M	6	3	<2
6M	10	3	<2
10M	15	5	<2

Obviously, PDM saves more time than Windchill in checking models in and out. That may be because Workgroup PDM doesn't use a web-based database. Each file in the vault has metadata, which is a series of text files that contain server options and file information. The picture below shows the structure of PDM.

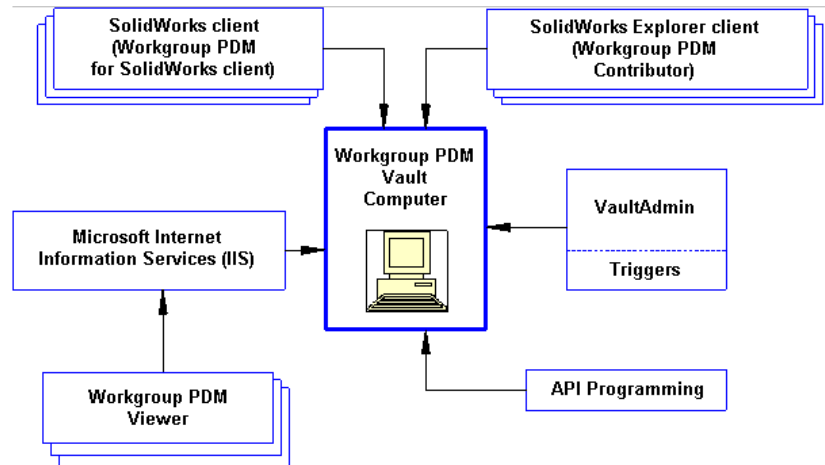

Figure 2 Structure of Workgroup PDM

As to Autodesk Vault, the structure is similar to PDM: A vault consisting of two components: a client and a server. The client allows you to perform document management functions, such as checking files in and out or copying designs. The server stores the master copies of all your documents and designs. By storing all your data in a common, centralized location, you can easily share and manage information with your

design team. This centralized location is called a vault. When you first launch the Vault client, you must select the vault that you want to log into before you can start managing your data. The following figure illustrates the basic configuration of the components.

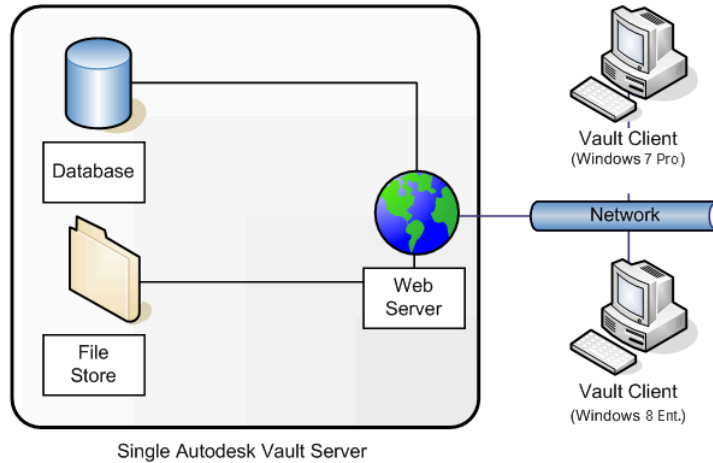

Figure 3 Structure of Autodesk Vault

As a result, the speed of Autodesk Vault may be almost the same as PDM.

5.3 CAD Model Management & Control

5.3.1 Windchill

One of the advantages of Windchill is that all the models can be viewed without opening Creo. If a team member just want to have a quick look at the model and know its dimension parameters, he/she just needs to achieve it by using an IE browser (Remember it should be in a standard mode). One can easily view the models in Creo view and calibrate the distance or angle of the part (shown below in Figure 4).

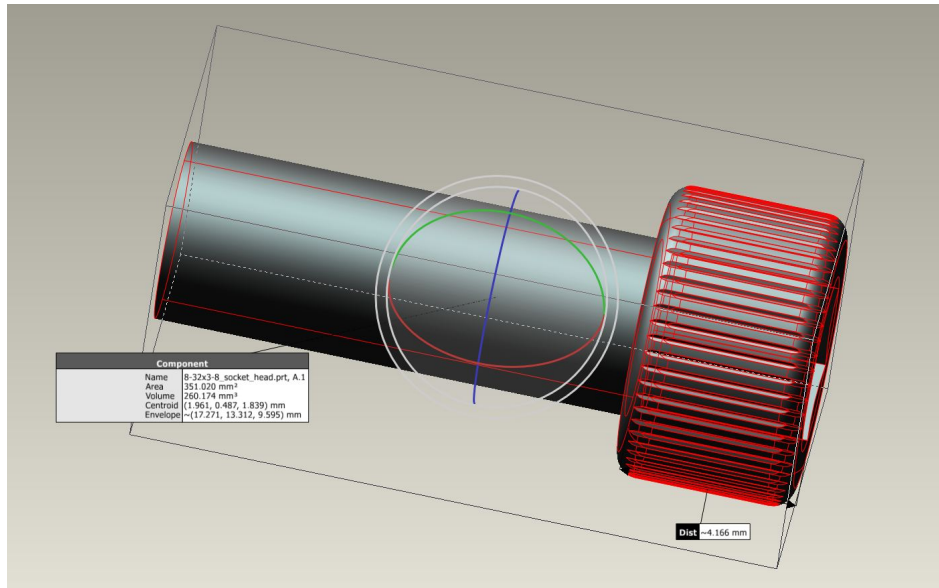

Figure 4 View CAD models in Windchill

As mentioned before, Windchill can also show the relationship between parts as well as record the history of all the changes of the models by a timeline. However, it may not record the detailed changes of the models (such as “cutting the length from 10 to 5”) and one has to record it manually. For the team these would be the most useful functions to manage models and they are not difficult to handle without considering other complicated features.

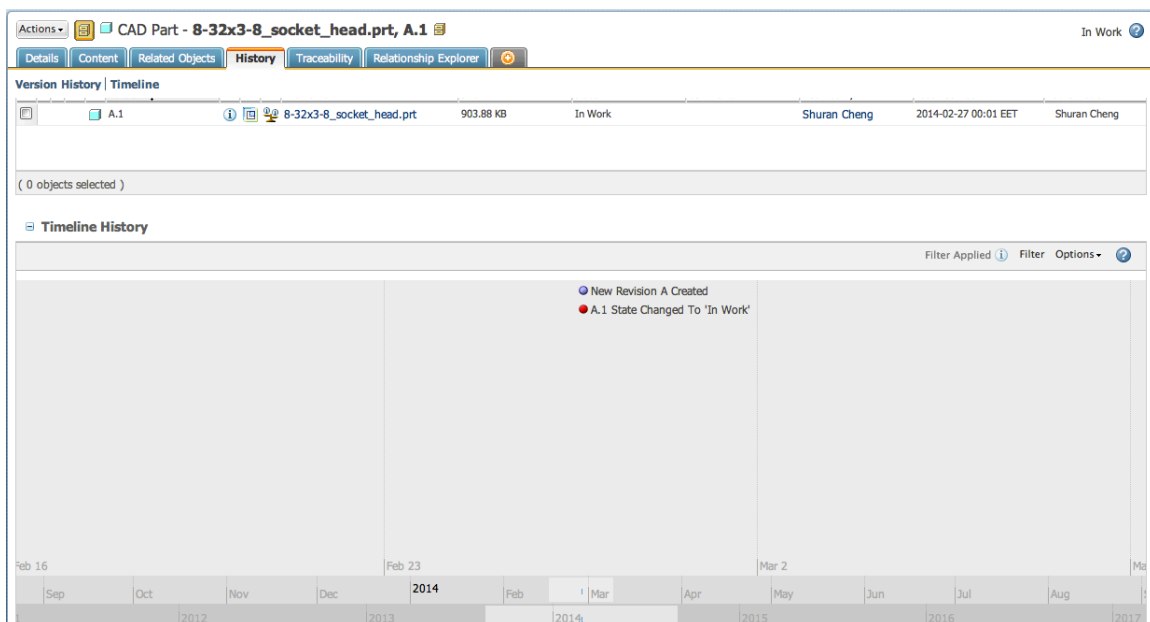

Figure 5 Revision history of CAD models in Windchill

5.3.2 Workgroup PDM

PDM allows the user to easily keep track of the change of a model. After logging in the vault, a member can clearly search for a part in the assigned folder and look up the history of the changes on the model as the following figure shows.

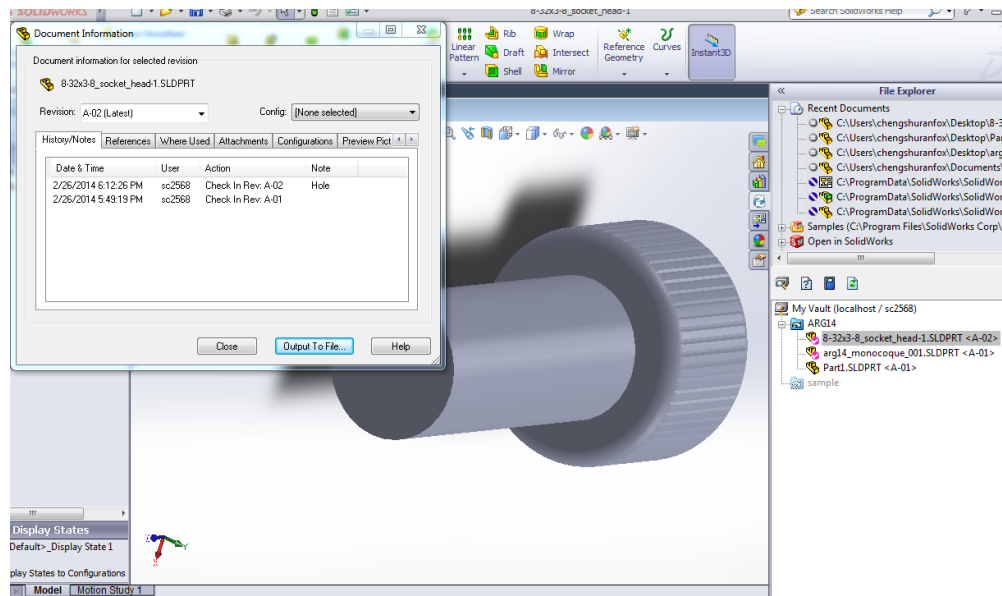

Figure 6 CAD mangement in Workgroup PDM

Besides, we can also see the changes visually. For example, below is a part on which a hole is added. From the preview window we can select different revision to see the changes on model. Same information can be gained from document information (the window in Figure 6). A note shows a hole is added with information such as the responsible user and date.

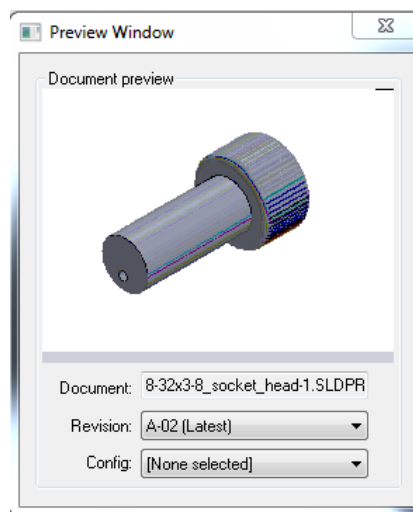

Figure 7 Review history in Workgroup PDM

5.4 Timeline

5.4.1 PLM 360

In PLM 360, one can easily create various tasks, which are included in different projects. Click the schedule tab, detailed information such as start/end date, status and timeline will be shown in time order, as the figure below. By changing the % complete of each task, the process of the program would be calculated automatically. If the whole process has to be delayed, we can quickly change all the due date by one day, one week or whatever time wanted. What's more, notifications will be sent by email to responsible person before deadlines in order to remind team members to finish their work on time. In a project or task, links of CAD information or files can be attached for the team's convenience.

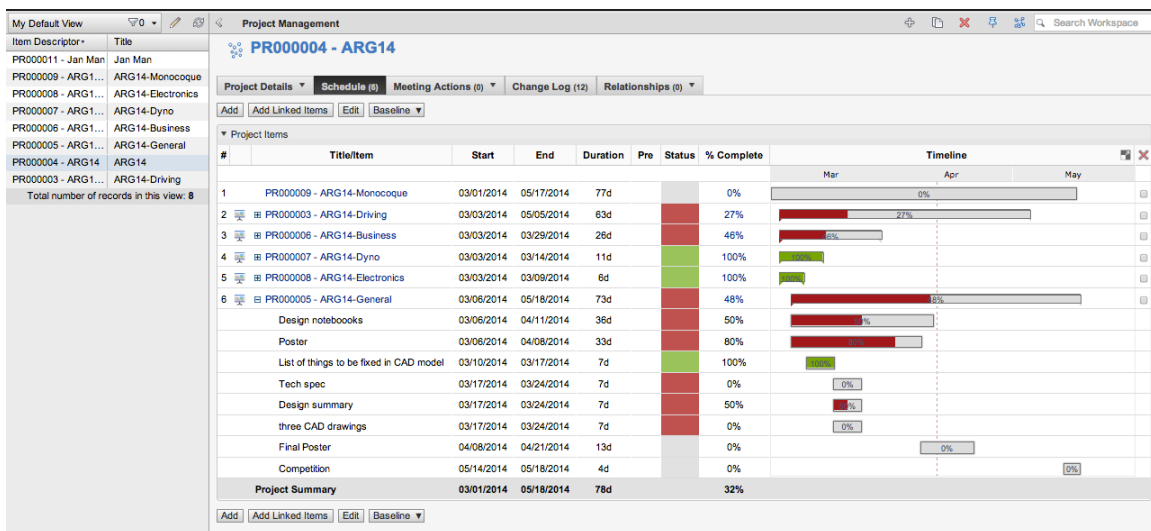

Figure 8 Timeline in Autodesk PLM 360

5.4.2 Arena

Arena attracts much attention for its highly customizable and easy to use project management settings. In the project schedule configuration page, we can set phases with milestones and drag phases or tasks to adjust order, as the figure below (Figure 9).

Similar to PLM 360, Arena provides clear display of the status and related dates of each task in a project and for every milestone or task, reference such as files, images, changes or even other projects can be attached. Also the project manager can adjust multiple due dates at once by using checkboxes and assign tasks to team members. For project management, Arena does a good job, but it is not included in the default module list, which means if organizations are interested in using Arena for project management, they have to spend extra money for this module.

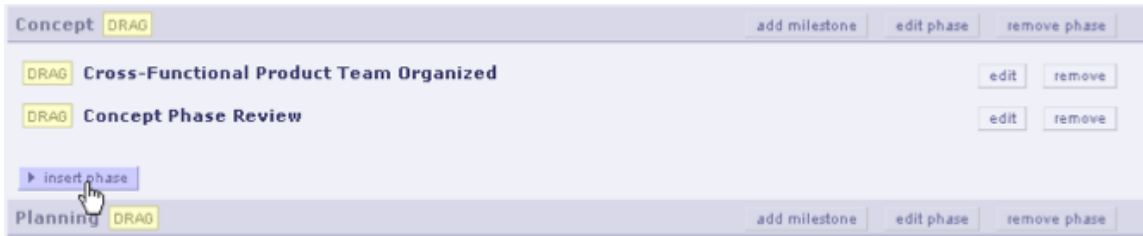

Figure 9 Timeline setting in Arena

#	Assignment	Assignee	MM/DD/YYYY Due Date	Status
	For competition — Not yet started		05/17/2014	
01	Truck Leaves	unassigned	05/13/2014	NOT STARTED
02	Rough draft of design posters due		Tue 04/08/2014	DONE Shuran Cheng, Sat 04/12/2014
03	Rough draft of design notebooks due		Fri 04/11/2014	DONE Shuran Cheng, Sat 04/12/2014
04	Mock design presentation	unassigned	04/12/2014	75%
05	Register for MIS awards <i>Register for the awards</i>	unassigned	04/14/2014	NOT STARTED
06	Final design posters due	unassigned	04/21/2014	NOT STARTED
07	Print design posters	unassigned	04/24/2014	NOT STARTED
08	Mock design presentation	unassigned	04/26/2014	NOT STARTED
09	Competition	unassigned	05/15/2014	NOT STARTED

Figure 10 Timeline in Arena

5.4.3 Google Doc

The team has been using Google Doc for a long time. It works as sharable excel sheets essentially. One of main reasons the team gets used to it is that it requires nothing for team members, as long as they have a Google account. For all the other software, each person needs register to get an account that can be done in a few minutes, though, which can make some overhead and resistance to starting a new way of system engineering. Undoubtedly Google Doc is super easy so everyone can use it without even spending time learning and it provides the unique vote feature. However, a professional project management tool may help save more time and better organize the timeline once everything is set. And since with Google Doc we cannot assign responsible person for a certain task and set up reminder emails sent from the software automatically, another task list is required (Figure 12). From this perspective the toughest issue is just the first step.

	A	B	G	H	I	J	K	L	M	N
1	Subsystem	Part Name	1/6/2014	1/7/2014	1/8/2014	1/9/2014	1/10/2014	1/11/2014	1/12/2014	1/13/2014
2			Monday	Tuesday	Wednesday	Thursday	Friday	Saturday	Sunday	Monday
3	Aero	Aero Wings			Glue foam, finish hot wire if needed	Make hotwire guides to cut airfoil shapes Cut foam waterjet inserts	Make hotwire guides to cut airfoil shapes Cut foam waterjet inserts	Cut foam waterjet inserts	layup wing elements	Finish cutting foam
4	Cooling	Radiator (Bleeder, filler neck, mount, taps) Lines				Machine Temp, bleeder and mounting bungs (lathe)	Machine Reducers & Ferrules	Arrive in Ithaca; Machine Ferrules; Make sure ALL CAD/design features are correct and ready	Cut and reweild tabs; move outlet; weld on bleeder bung and mounting bung; weld neck (cap) on; Cut mounting tabs, support arm and cap	Complete Radiator Modifications, machine ferrules
5	Cooling	Manifolds				LCM Flange and UCM Cup get NC'd and LCM taper (lathe)	finish UCM Cup NC	Arrive in Ithaca		Miter/Weld/Assembl LCM, make UCM on NC, start tubular parts
6	Cooling	Fan Duct								Start making test bed
7	Drivetrain	CVs & Halfshafts		Hub Sleeves finished. CVs turned	Hole already drilled through halfshafts. Lathe halfshafts					Machine pins, plugs, and halfshaft rings on lathe. CVs go into mill
8	Drivetrain	Sprocket								
9	Drivetrain	Bearing Carriers			Machine clevises	Machine clevises	Machine clevises	Machine clevises	QC clevises	Machine Eccentrics and clevises

Figure 11 Timeline in Google Doc

	A	B	C	D	E	F	G	H	I
1	Status	Car	Reporter	Issue	Person Responsible	Due date	Notes		Color Code
3	✓	General/Lab	Jesse Greene	Fuel jugs leak everywhere	Claire Krejci	Done	Ordered		Due
4	✓	Dyno	Jesse Greene	Blast shield plan	Timothy Cook	Done			
5	✓	Dyno	Jesse	02 Sensors	Timothy Cook	Done			
6	✓	Stock Car	Pherson	Fix seat	Nicholas Carrillo	Done			Past due
7	✓	Shifter Kart	Jesse	Brake rebuild kit	Michael Necky	Done			
8	✓	General/Lab	Jesse	Sensor list. List of MoTeC calibration location and sensor data sheet location,	Christopher McPherson	Done			
9	✓	ARG14	Derek Paxson	Heat shield for headers	Ankith Harathi	Done			On hold
10	✓	General/Lab	Hsia	Clean up freezer in Olin	Alexander Hsia	Done			
11	✓	General/Lab	Nina Buchakjian	Inventory ratchet straps for comp	Jesse Greene	Done			
12	✓	Yellow Kart	Jesse	Fuel tank mount	Michael Necky	Done			Done!
13	✓	ARG14	Tim	Wiggins to hose adapters for up-pipe	Daniel Cykman	Done			
14	✓	ARG14	Derek	Fuel rail tab to intake	Claire Krejci	5/7/2014			
15	✓	General/Lab	Jesse Greene	Get rid of foam	Anthony Boiano	Done			
16	✓	General/Lab	Tim Cook	Rebuild carb on generator	Michael Necky	4/25/2014			
17	✓	General/Lab	Hsia	Make Percy's legs	Alexander Hsia	Done			
18	✓	General/Lab	Tim Cook	Rebuild the yellow centrifugal fan	Jonathan de la Fuente	Done			
19	✓	General/Lab	ARG	Status update on helmets and suits	Prateek Aikesh	Done			
20	✓	General/Lab	ARG	Make pushbar	Gregory Pon	5/4/2014			
21	✓	ARG14	ARG	Heat shielding on firewall	Benjamin Rolewicz	Done			
22	✓	ARG14	ARG	Larger washers for suspension points	Vivian Lu	Done			
23	✓	ARG14	ARG	Guard for brake lines in the rear - check thickness	Meilin Dong	Done			
24	✓	ARG14	ARG	Check bolt specs for main hoop bracing	Donald Feng	Done			
25	✓	ARG14	ARG	Aluminum block off panels for neck protection	Matthew Eisner	Done			

Figure 12 Task list in Google Doc

5.5 Change Control

5.5.1 PLM360

Take a recent change, the bearing carrier clevis, for example. Using PLM 360, the change control includes description, priority, change of cost and so on. From the workflow of change control (Figure 14) we can see the process of a change: a record owner creates the report and waits the change to be reviewed and approved by team leaders and advisors. Both the record owner and permission setting can be changed and a remind email will be sent to previous responsible people. To create a change control report, the owner doesn't need to import part information to the BOMs system of the software because the change control is not connected to the part library. Part image and

change report can be attached in the section. A normal change control report can be created within 3 mins.

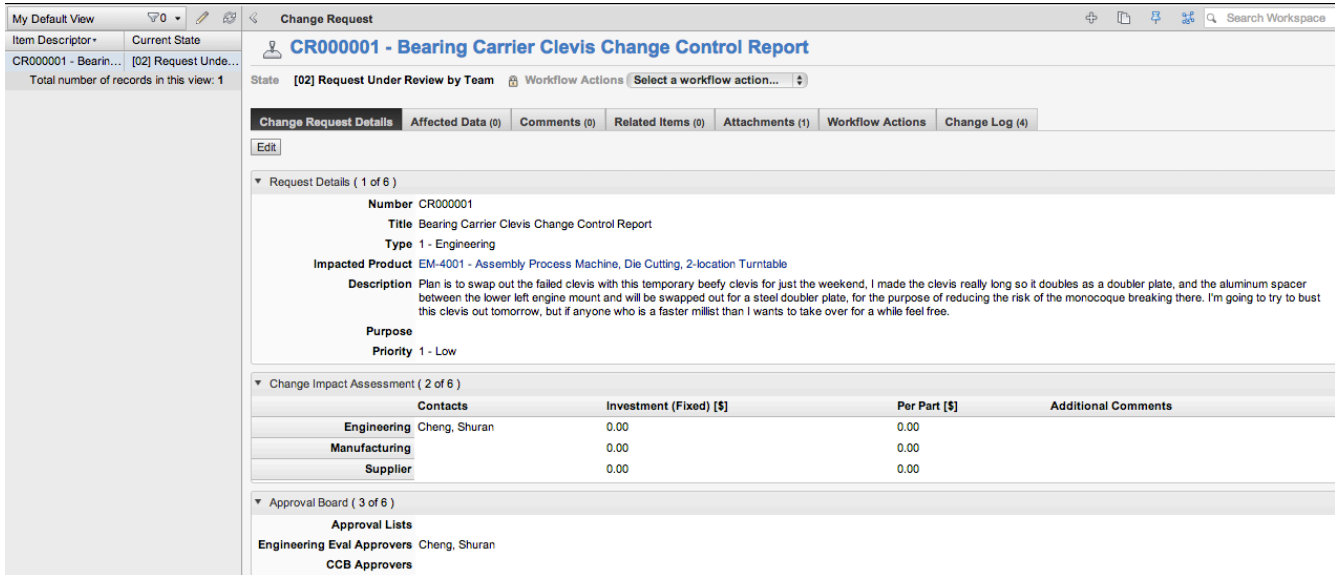

Figure 13 Change control in PLM 360

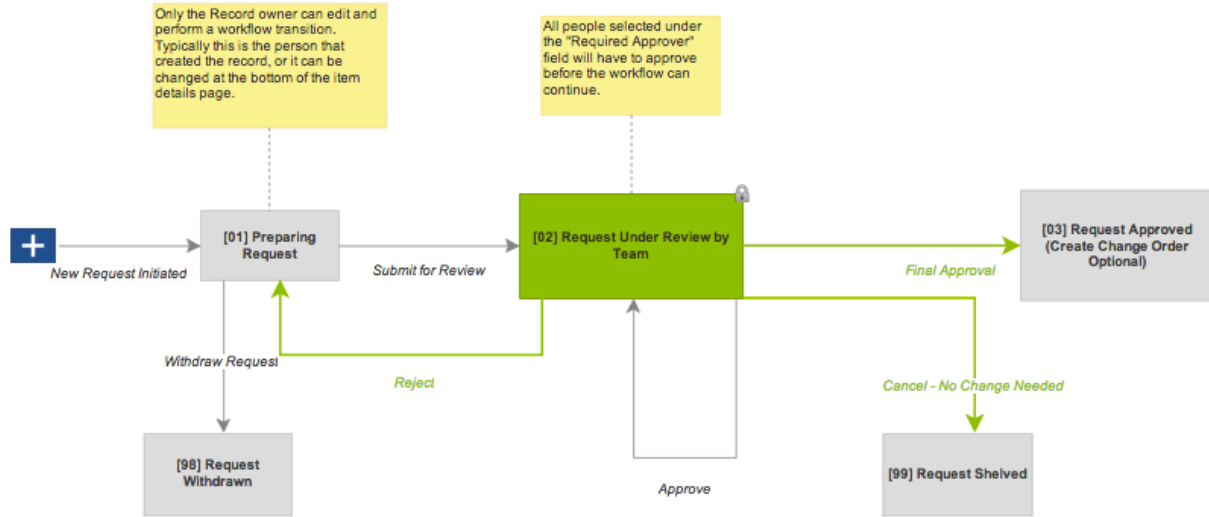

Figure 14 Chang control workflow in PLM 360

5.5.2 Arena

Similar to PLM 360, change control in Arena includes fundamental information such as part data, status and owns a more complex workflow with open stage, submitted stage and released stage. The most different thing is that, to create a change control in Arena, the responsible person has to import the component information to the library in advance,

and just link the change to one of existing part. It may require more time building a improved part library but once done, much time will be saved in creating both change control report and BOMs for cost report. This individual change control costs about 8 mins.

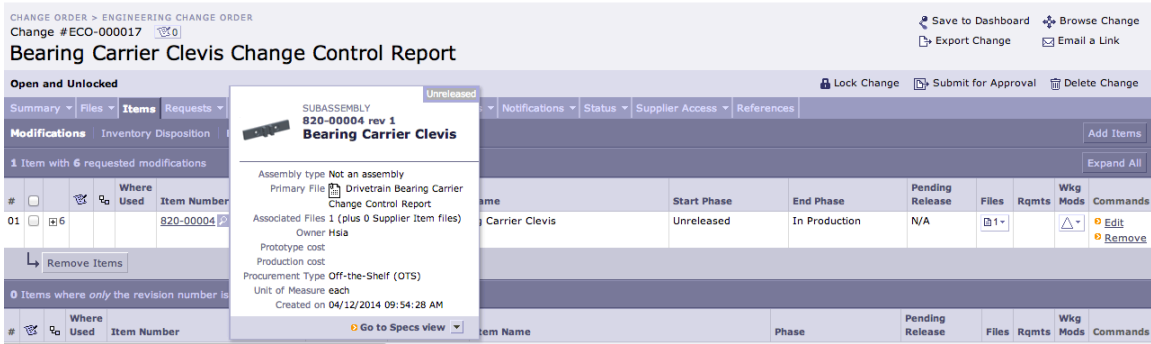

Figure 15 Change control in Arena

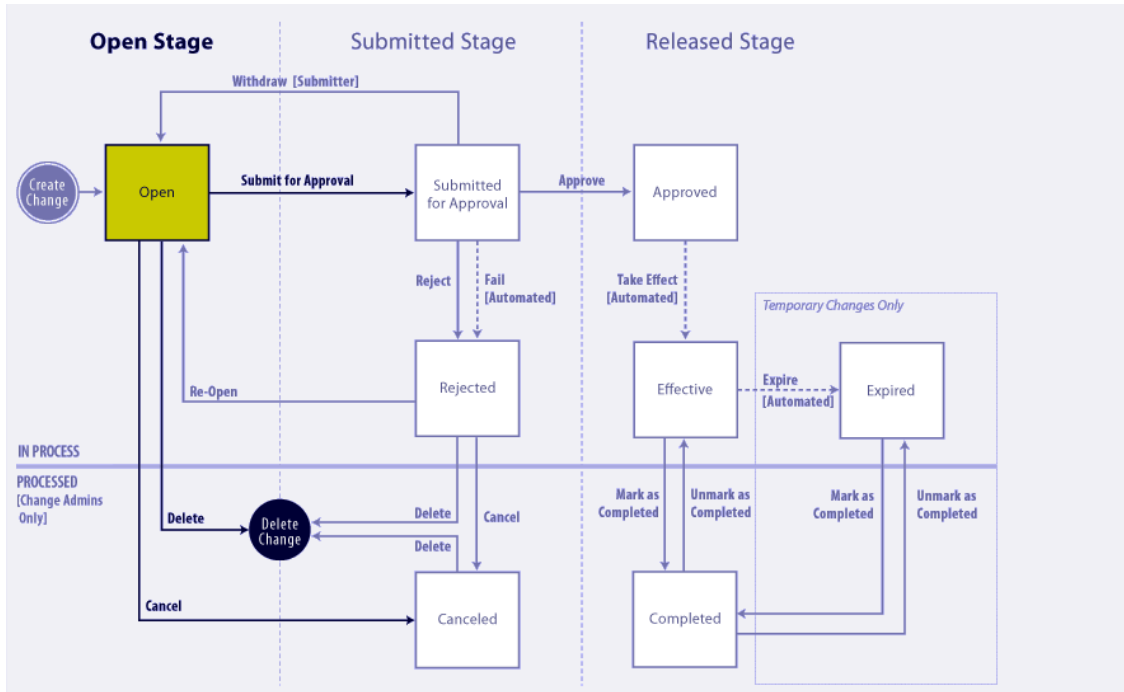

Figure 16 Change control workflow in Arena

5.5.3 Windchill

Standard change control in Windchill also requires an existing part library, but it is even more complicated than Arena so we didn't test it. However some attempts were tried by building a file and save change control reports in the document. In this way there won't be any workflow with review and approval process. As a result we would not use Windchill as a tool for change control.

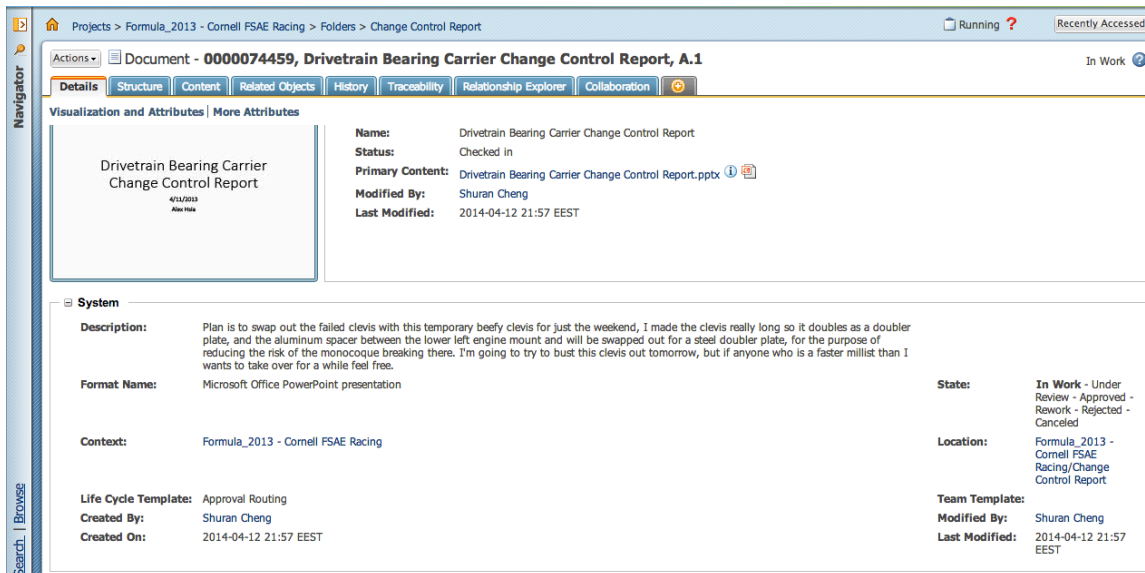

Figure 17 Change control in Windchill

5.6 Meetings Records

5.6.1 Windchill

The team holds two general meetings and sub-team meetings each week and meeting minutes allow all the members to look through what's going on and to keep track of process if needed. Windchill owns perfect way to record a meeting with details of subjects, host, time and minutes. It is one of the best functions for the team besides an online CAD models view. Currently meeting information and minutes are informed through emails and files are saved on S-Drive, which is pretty efficient but someone may be bothered by so many emails that have nothing to do with themselves. With a web-based software one can easily look up any minutes by any mobile device without keeping huge amount of emails or search in S-Drive. Basically it is the same way with looking up other program related information, that's why we regard web-based software as a preference.



Figure 18 Meeting record in Windchill

5.6.2 Other tools

For other software such as Arena and PLM 360, there is no default workspace especially for meeting records, but it is not hard to create a project or workspace for meeting (Figure 19). After setting down all the section properly, a meeting record workspace can also include date, status and attached minutes. Recording the meetings and project management can be the first step we start using these professional tools since they don't require complicated settings and skills and do bring benefits to the team in terms of time saving and efficiency.

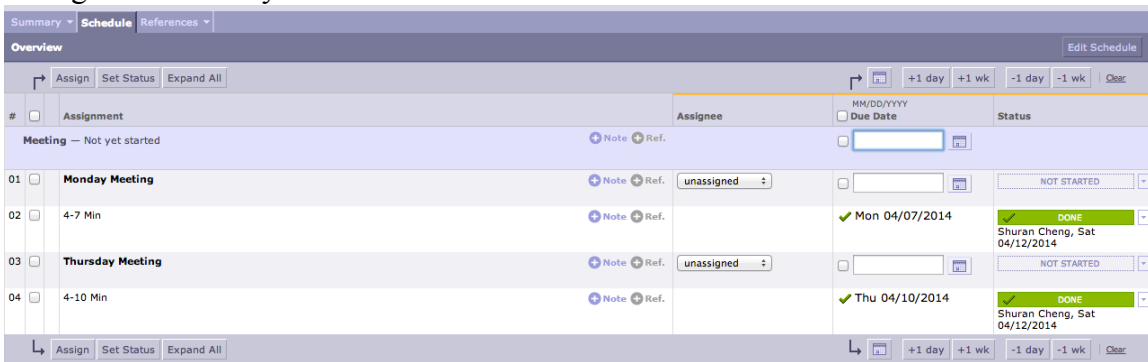



Figure 19 Meeting record in Arena

5.7 History

PLM 360, PDM Groupworks and Google Doc provide detailed records of change history while Windchill only shows recent workspace visit by the owner. As mentioned above, PDM Groupworks displays each version of a model and comments given by different

designers to show clearly the whole revision process of a CAD model. In PLM 360, for each workspace there is a Change Log tab recording changing time, person, actions and descriptions. Changed content is marked in green and previous content is in red, as shown below. Similarly, in a Google Doc spreadsheet, everyone who is invited to a document has the right to view all the changes of the spreadsheet. Change history helps verify if the change should be approved and avoid confusions. It is very important to keep track of task list, for example. If two system engineers are keep charge of it, one marks a certain task as done, and then some problems appear but only the other engineer knows it turns back to “unfinished”. Without a changing history record, none of them may notice the wrong status of this task considering hundreds of tasks in the list. As a result this function is necessary for the team to avoid mistakes and errors.

 **PR000005 - ARG14-General**

Project Details ▾ Schedule (8) Meeting Actions (19) **Change Log (8)** Relationships (0) ▾

▼ Change Log 1 2 3 4 5 >> Last

Date Time	Changed By	Action	Description
03/18/2014 3:21:00 PM	Shuran Cheng	Add rows into grid	Row 23: <ul style="list-style-type: none"> Action: Design poster Due Date: 04/08/2014 Responsible: Notes: Rough draft of design posters due Complete: No ⇒ No
03/18/2014 3:16:46 PM	Shuran Cheng	Undelete Item	This item was undeleted
03/18/2014 3:16:39 PM	Shuran Cheng	Delete Item	This item was deleted
03/18/2014 3:14:40 PM	Shuran Cheng	Edit Project Item	• : Wed-Mar-19-00:00:00-EDT-2014 ⇒ Mon Mar 17 00:00:00 EDT 2014
		Edit Project Item 'three CAD drawings'	
03/18/2014 3:14:20 PM	Shuran Cheng	Edit Project Item	• : Mon-Mar-17-00:00:00-EDT-2014 ⇒ Wed Mar 19 00:00:00 EDT 2014
		Edit Project Item 'three CAD drawings'	
03/18/2014 3:14:01 PM	Shuran Cheng	Edit Project Item	• : Wed-Mar-26-00:00:00-EDT-2014 ⇒ Mon Mar 24 00:00:00 EDT 2014
		Edit Project Item 'three CAD drawings'	
03/18/2014 3:13:21 PM	Shuran Cheng	Edit Project Item	• : Mon-Mar-24-00:00:00-EDT-2014 ⇒ Wed Mar 26 00:00:00 EDT 2014
		Edit Project Item 'three CAD drawings'	
03/18/2014 3:12:35 PM	Shuran Cheng	Edit Project Item	• : Tue-Mar-18-00:00:00-EDT-2014 ⇒ Thu Mar 06 00:00:00 EST 2014
		Edit Project Item 'Poster '	
03/18/2014 3:11:34 PM	Shuran Cheng	Edit Project Item	• : Thu-Mar-06-00:00:00-EST-2014 ⇒ Tue Mar 18 00:00:00 EDT 2014
		Edit Project Item 'Poster '	

Figure 20 History record in PLM 360

The screenshot shows a Google Doc titled "ARG14 Master" with a menu bar (File, Edit, View, Insert, Format, Data, Tools, Help) and a toolbar. The main content is a table with the following columns: Date, Time, Activity, Volunteer #1, Volunteer #2, Volunteer #3, Volunteer #4, and Volunte. The table contains data for activities from Monday (5/5/2014) to Sunday (5/11/2014). A "Revision history" sidebar is open on the right, showing a list of changes with timestamps (e.g., "Today, 7:22 PM PT") and user names (e.g., "anonymous", "Amanda Costello"). At the bottom of the doc, there is a status bar with a timer showing "00:07 08:32:39" and a list of links: "Truck Packing", "Spring Peer Eval #2 Sign-Up", "Change Control", "The Big Red List", "Monocouque To-Do List", "Timelines", "Monocouque Slots", "Work Sessions", and "Parts to be machine".

Date	Time	Activity	Volunteer #1	Volunteer #2	Volunteer #3	Volunteer #4	Volunte
Monday	23:00:00	Bolt Check	Eisner	Nina	DD	De La Fuente	
	9:30:00	Truck Pack	Owen	Greg	Kern		
	12:30:00	Driving @ Groton					
Tuesday	20:00:00	Cooling	Timbo	Larry	Christine	Doug	
	20:00:00	Bolt Check	Hsia	Tim	Necky	Ankith	DD
	6:00:00	Truck Pack	Nina	Brendan	Kern		
Wednesday	8:30:00	Driving @ Glen	Derek	Endo	Owen		
	20:00:00	Bolt Check	Sarah	Marlon	Jeff Chung		
	6:00:00	Truck Pack	Timbo	Nina	Kern		
Thursday (Slope Day)	7:00:00	Driving @ Groton	Connor	Pherson	Kern		
	20:00:00	Bolt Check	Christian	Kern	Prateek		
	6:00:00	Truck Pack	Pherson	Rain	Kern		
Friday	8:30:00	Driving @ Glen	Pherson	Endo	Marlon	Rain	
	20:00:00	Bolt Check	Balinsky	Ryan	Eisner		
	6:00:00	Truck Pack	Christian	Connor	Jeff Chung	Sarah	
Saturday	8:30:00	Driving @ Glen	Endo	Sam	Connor	Prateek	
	20:00:00	Bolt Check	Rain	Ryan	Connor		
	6:00:00	Truck Pack	Rain	Claire	Nina		
Sunday	8:30:00	Driving @ Glen	Endo	Christian	Doug	Gumby	
	20:00:00	Bolt Check	DD	Ryan	Marlon		

Figure 21 History record in Google Doc

5.8 PTC Integrity and Traceability Matrix

At the end of the semester, PTC Integrity became an extra option for the team. As an on-premise software, it can be integrated with Windchill. According to Erich Leonard, his company, New York Air Brake, uses PTC Integrity to achieve the requirements management, to store and trace customer requirements to system requirements, sub-system requirements, software and hardware requirements. Another tool, the Traceability Matrix, also contributes a lot to the requirement management. In different sheet we can set customer requirement, system level requirement and sub-system requirement. Descriptions and approval are available. Figure 22 presents the home page with links to all the wanted tables or matrix. Figure 23 and Figure 24 show system level and co-effect of customer and system level requirement (we can figure out from the matrix if a component meets both customer requirement and system requirement). These methods may help the team at the beginning of the year to set up objectives and summarize what we can improve for next year's car and prepare for future design report. Further research could be done next year.

decision can be based on the type of functions needed from PLM implementation and the difficulty to start and use it.

For the Cornell FSAE team, if PLM is to be adopted on a permanent basis, the most recommended product is Autodesk software. PLM 360 proved to be the easiest and most efficient tool for project management and according to previous report, Vault did a good job on CAD management. Moreover, if the team decides to move to Inventor as a CAD software using both these software together would produce significantly better results in terms of collaboration and data management. However, to achieve this, much work should be done with the lab computer, such as software installation and server management. Technical engineers from Autodesk provided great help and were willing to sponsor the software to us. We basically gave up Windchill for its complexity and compatibility issues (models can only be opened in IE browser when the compatibility mode is closed).

Moreover, it will be easier to put the software into use if all the members can realize how important it is for the team from the whole picture. Sometimes the toughest step is just the first one. And undergraduate may also be accepted for this project to keep the continuity since MEng student may only be responsible for it for only one year.

At the end, many thanks to Prof. Albert George, Jesse Greene, Lei Wen, all the IT department and lab faculties and technical support from Autodesk, SolidWorks and Arena who put a lot of time and effort to help. Hopefully the team can implement professional PLM software and improve management process for a even better racecar.

Reference

- [1] Sanyukta Das, Product Lifecycle Management For Cornell FSAE Team[D]. Cornell University, 2013.
- [2] Top 10 Product Lifecycle Management (PLM) Software Report[Online]. Available: http://ptccreo.files.wordpress.com/2013/10/top_10_plm_report.pdf.
- [3] Software As A Service As An Outsourcing Model: An Economic Analysis[Online]. Available:[http://www.google.com/url?sa=t&rct=j&q=&esrc=s&source=web&cd=1&ved=0CDkQFjAA&url=http%3A%2F%2Fwww.researchgate.net%2Fpublication%2F228447677_Software_as_a_Service_\(SaaS\)_as_an_outsourcing_model_An_economic_analysis%2Ffile%2F32bfe51194c3688c94.pdf&ei=KN5oU_mMBvSusAS5joCoAw&usg=AFQjCNHUAKX-0BfKHMHrdHpR9Lfu5Jbm-w&sig2=lioHYNMNHb1q7FPxR231cQ](http://www.google.com/url?sa=t&rct=j&q=&esrc=s&source=web&cd=1&ved=0CDkQFjAA&url=http%3A%2F%2Fwww.researchgate.net%2Fpublication%2F228447677_Software_as_a_Service_(SaaS)_as_an_outsourcing_model_An_economic_analysis%2Ffile%2F32bfe51194c3688c94.pdf&ei=KN5oU_mMBvSusAS5joCoAw&usg=AFQjCNHUAKX-0BfKHMHrdHpR9Lfu5Jbm-w&sig2=lioHYNMNHb1q7FPxR231cQ)
- [4] <http://www.mindtouch.com/blog/2008/05/28/differences-between-saas-and-cloud-software/>
- [5] <http://www.techopedia.com/definition/26714/on-premises-software>
- [6] Ross Mistry and Stacia Misner. Introducing Microsoft SQL Server[Z], 2012.
- [7] <http://www.ameplm.eu/index.php/pdmplm-useful-information>
- [8] <http://www.fsae.com/forums/archive/index.php/t-3820.html?s=2f4ac3793225a1cc9fb6f05198249449>
- [9] <http://www.fsae.com/forums/archive/index.php/t-10227.html?s=2f4ac3793225a1cc9fb6f05198249449>