

Sedimentation Tank Design Details

by Paroma Chakravarty and Tiange Guo

Fall 2013

Problem Definition

Introduction

This semester, our task is to update the sedimentation tank code. These changes include implementing new designs based on recent research from the Summer 2012 Team and ridding the tank of unneeded pieces. The first priority we focused on was implementing the new asymmetric inlet jet design for the sedimentation tank. Based on the experiments and findings of the Summer 2012 Sedimentation Tank Hydraulics team, we knew that compared to a centered jet which would have water hit the bottom of the jet reverser at a perpendicular angle, a vertically placed asymmetric jet is ideal for floc resuspension because it eliminates the possibility of sludge buildup in the reverser due to preferential flow paths taken by the jet. Therefore, the task required us to shift the inlet jet off center (Figure 1). Consequently, we need to calculate the shifting distance, update the design code and implement the new designs. We are also focusing on adding “feet”, or supports, to the manifolds (Figure 2). This includes calculating the size of the feet and their placement based on specifications from past fabrication teams.



Figure 1: Centered Jet and Asymmetrical Jet



Figure 2: Manifold Feet created by a AguaClara Fabrication Team

Design Details

Using May's updated Sedimentation Tank code, we needed to shift the inlet jet from the center to an unspecified distance to the right when viewing the drawing from the right. Though we were required to only move the inlet jet, the code was structured so that we had to shift the entire manifold to make this change. Though the research team did not articulate in their report whether the inlet jet needs to touch the tank wall, we set it an arbitrary distance away from the wall in the code so that sludge does not build up behind the inlet jet. Once the shift has been made, feet to support the manifold pipe had to be added. These feet are comprised of two pipes of different lengths located at two places along the manifold pipe. The original report assumed the manifold pipe would be centered in the bay, so the length of each foot was equal and calculated in the same way. The shifted manifold posed a challenge because two new length equations had to be derived. We used similar triangles and trigonometry to derive these equations. The feet design included hose clamps, so these needed to be added to the sedimentation tank drawing code. In the design, the hose clamps are meant to fasten the feet to the manifold and ensure that they stay in place.

Documentated Progress

Asymmetrical Inlet Jet Placement

Based on May's updated sedimentation tank code, we calculated the radius of the jet reverser and added that to the y component of the sedimentation manifold pipe origin. While this shifted the manifold and inlet jet over, it created a new issue of how to draw the floc weir baffle and a semi circle cutout

for the manifold pipe to fit into the baffle. Originally, the code drew the baffle and cutout in one bay, mirrored that to the adjacent bay, and then arrayed that for as many sedimentation tanks as needed. This method was not working for the newly shifted manifold because the baffles with the cutouts were no longer symmetrical within a sedimentation tank. After some trial and error, we decided to first draw the baffle, mirror it to the second bay, then draw the semi circle cutout in the first bay and array that to the second bay. Then, the whole sedimentation tank can be arrayed to the required number. After we had successfully moved the inlet jet to contact the edge of the jet reverser, we found that we had to leave some space between the outlet jet and the wall to avoid sludge build up. Therefore we named that distance $S_{FromSedWall}$ in the code and set it equal to 1inch temporarily. If a research team finds an optimal distance later on, they can change the distance based on their data. After initially setting the inlet jet 1 inch away, we found that the jet also needed to be shifted up the same distance to further prevent sludge build up. This required us to shift the manifold origin point in the positive z direction by our new distance variable. Again, if a research team finds an optimal distance, this shift can be changed by just changing the $S_{FromSedWall}$ variable (Figure 3).

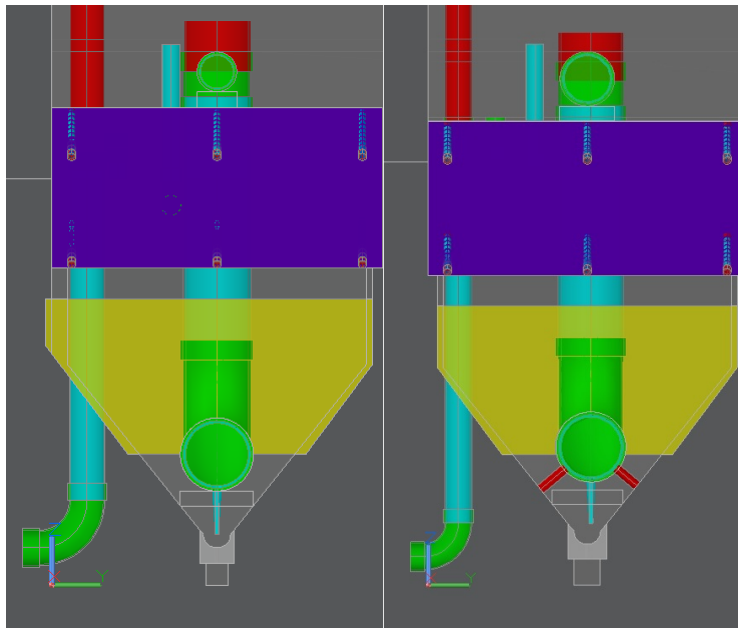

Figure 3: Before and after comparison of manifold and inlet jet

Manifold Feet

Adding feet to support the manifold involved calculating the length of each foot and the angle and area of placement. According to May's original code, the feet added to the manifold should have been symmetrical since the manifold was centered. After we shifted the manifold over to the right side, we needed two differently sized feet for supports. The longer foot is placed to the left of the manifold when the drawing is viewed from the right. The shorter foot is placed to the right of the manifold from the same view. This pair is then arrayed to a place further down the manifold. This location is not specified in the research report, so it is currently a variable in the design code. The design task assignment included a formula to calculate the length of the feet, but this calculation assumed the manifold to be centered in the tank. Our off-center manifold required us to come up with a new formula for the length calculations. At first, we thought that by simply adding the distance of the offset manifold to the length calculation we could calculate the length of the longer foot, but this did not turn out correctly when we drew the manifold and feet in AutoCAD. After some analysis, we decided to set the feet perpendicular to the wall to best support the manifold. We set the origin points of the feet with respect to the origin points of the manifold pipe. The x- origin points of the feet are set to an arbitrary length away from the x-origin of the manifold pipe because the location of the feet have not been specified yet. In order to derive the y and z origin points of the feet, we used trigonometry. Our method can be found in the sketch below (Figure 4). A similar method was used to calculate the lengths of the short and long feet (Figure 5). At first we thought that the long leg of the big triangle is equal to the z-origin of the manifold minus the z-origin of the center point of the jet reverser, but this was incorrect. After some analysis, we found that the long leg should be equal to the inner radius of the manifold plus the length of the diffuser plus the h.additional distance that we calculated. Since the AN.SedSlope is given, the length of H.additional was calculated by using the sum of the width of the diffuser outlet, the thickness of inlet jet and S.FromSedWall. Though this makes mathematical sense, the length would only fit if we multiplied elements of H.additional in odd ways (Figure 5). It still needs to be ascertained how and why these calculations work. After we calculated the length of the long leg of the big triangle, we calculated the length of the short leg by using AN.SedSlope. Then we calculated the distance from the manifold center to the wall using the same angle and calculated the foot length by subtracting the outer radius of the manifold. While this method makes mathematical sense, there were again issues in the length and placement of the long foot. We manipulated our code in order to make the feet fit and checked the accuracy of these calculations at different plant flow rates. The lengths seem to be accurate at all flow rates, but we are unsure as to why. Lastly, we added hose clamps to hold the feet securely to the manifold pipe. All specifications for the hose clamps were based on the feet locations and width of the manifold pipe.

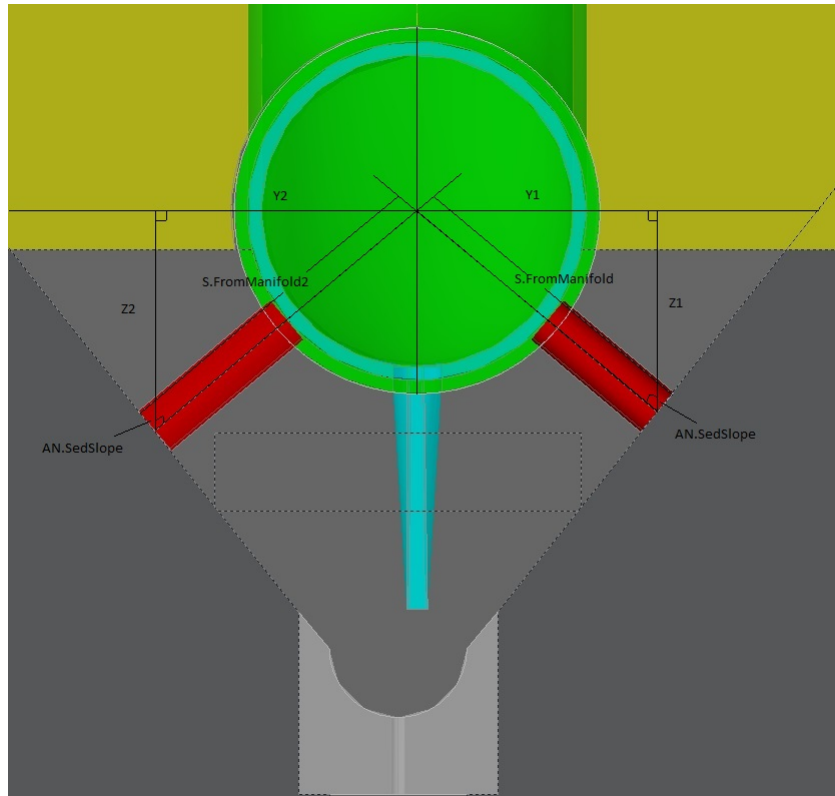

Figure 4: Calculation of origin points for manifold feet

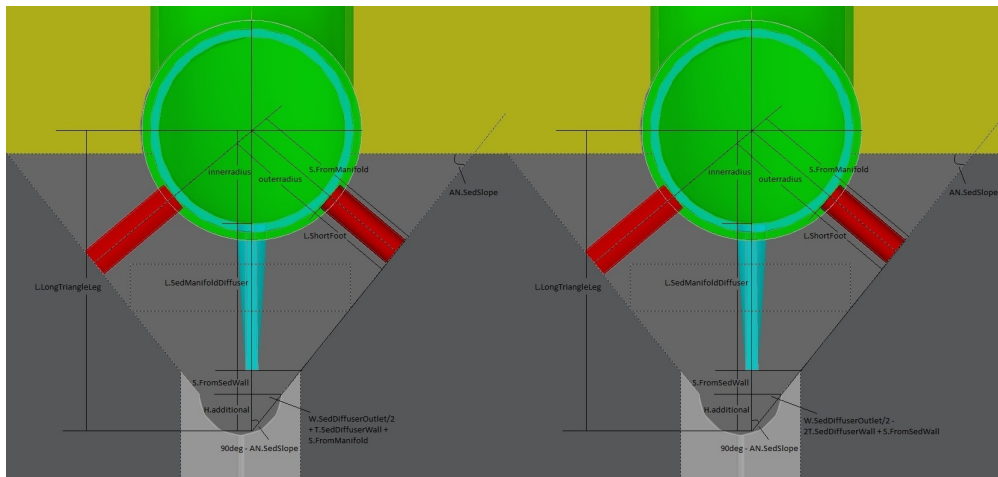

Figure 5: Theoretical versus real calculations of feet length

Future Work

Future teams should focus on finding definite values for the arbitrary distances we have set. The code should also be analyzed to identify why the methods we used to make the feet fit worked. Besides, future teams can just mirror the feet about the point that is half the length of manifold instead of making the arraying distance a variable. Lastly, May should be contacted to see if there are other details that need to be updated in the sedimentation tank code.