

StaRS Filter Theory, Spring 2016

Theresa Chu, Lucinda Li, Jonathan Harris

May 19, 2016

Abstract

A mathematical model describing sand filtration would promote the understanding of stacked rapid sand filter performance. Variables affecting filter performance include coagulant dosage, influent turbidity, and sand filtration depth. The collected data from a model filter informed a mathematical model explaining the effect of coagulant mass on the filter's effluent turbidity, head loss, and failure time. Experiment runs demonstrated that increasing coagulant dosage led to an increase in head loss and decrease in time until filter failure as well as vary effluent turbidity. Head loss curves for the various PACl dosages had the same trend after filter failure and converged to the same value after a 24 hour run time.

Introduction

The stacked rapid sand (StaRS) filter was implemented to filter particles too small to be removed by the previous processes of flocculation and sedimentation. In the AguaClara treatment plant, the filter has six layers of sand, each with a water pipe embedded within. There are two types of pipes with a slotted pipe design, the inlet pipe that allows water to enter and the outlet pipe that allows water to exit. The placement of the pipes alternate with each layer, resulting in a total of four inlet pipes and three outlet pipes. In recent implementations of the filter, the slotted pipe design for the inlet pipe was replaced with a pipe design where water is injected through a downward-facing orifice. After a certain duration of filtering, the process of backwash is used to clean the filter by sending water into the filter from the bottom, causing the sand to expand and fluidize such that the particles collide with each other. This process allows any particles stuck on the sand to be loosened, sent up the column, and washed out of the filter.

The overall aim of the StaRS Filter Theory team is to develop of an empirical mathematical model that gives conclusive data about the StaRS filter, given a set of design and operating parameters. The model should predict head loss as a function of coagulant dosage and the mass of solids accumulated in the filter, given a constant influent turbidity. From this model, one would then be able to compute the filter efficiency with respect to effluent turbidity and head loss until filter failure or excessively high head loss.

The team has redesigned the apparatus that was most recently modified last semester. The new design switched the three-roller pump head to a six-roller pump head, created a new flocculator with 3.175 mm ($\frac{1}{8}$ in) size tubing, reintroduced a flow accumulator to prevent pulsing from the peristaltic pump, and

added a check valve to prevent sand from exiting the filter. In addition, humic acid was incorporated in the clay mixture to better model the environmental conditions at the AguaClara plant sites. The apparatus will continue to be adjusted as necessary to accommodate upcoming experiments.

Literature Review

Flocculation is the process of colliding particles to create larger particles, or flocs. This process occurs after coagulation, where the water is treated with coagulant that causes the particles to adhere to each other. Flocculation does not directly reduce turbidity, but facilitates particle removal in later treatment processes by creating larger flocs that will settle or filter out more easily Conradin et al. (2010). There are two types of flocculators: hydraulic and mechanical. Hydraulic flocculators, used in AguaClara plants, are gravity-driven and use vertical or horizontal baffles to create turbulence in the water. Mechanical flocculators use stirring to cause collisions and require electricity Weber-Shirk (2015).

Flocculation efficiency is affected by the flocculator design and turbidity. Coagulant loss due to walls can be significant, especially for low values of turbidity. As shown in Figure 1, small diameter tubing only allows a small fraction of coagulant to attach to the clay.

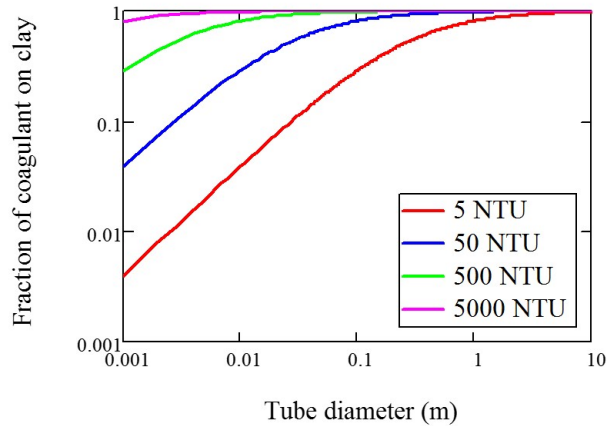

Figure 1: Loss of clay to reactor walls is dependent on influent turbidity and tubing size. A small tube diameter and low influent turbidity will result in less coagulant attaching to clay.

For 5 NTU influent water and tubing with an inner diameter of 3.175 mm ($\frac{1}{8}$ inch), only about 1% of the coagulant will attach to the clay Weber-Shirk (2015).

In waste water treatment systems, coagulant is often used to collect dispersed particles into aggregates. Polyaluminum chloride (PACl), a coagulant commonly employed due to its turbidity removal efficiency, is the subject that will aggregate suspended kaolinite particles in this study. PACl reacts with

dispersed particles through two mechanisms: neutralization and precipitate enmeshment. Neutralization is dependent on the surface chemistry of PACl and the kaolinite particles; PACl is positively charged at an acidic or neutral pH while kaolinite is often negatively charged. As a result, the kaolinite particles repel one another, thus preventing aggregation. When PACl is added to a solution of kaolinite suspensions, the particles are neutralized and can then form aggregations, increasing the size of the particles. However, aggregation size is limited by the small molecular weight of inorganic polymers found in coagulants (Liang et al. (2016)).

The other mechanism implemented is precipitate enmeshment; PACl and kaolinite particles can form precipitates when they collide, allowing other dispersed particles to be enmeshed within the precipitate. As aggregates increase with size, their settling velocities also increase. In an article by Liang and other researchers, it was determined that the optimal concentration of PACl for the highest settling velocity is $20 \frac{\text{mg}}{\text{L}}$. It should also be noted that a concentration above that resulted in a decreased settling velocity. This is caused by the re-dispersion phenomenon, the formation of an electrical double layer repulsion when there is an overdose of coagulant (Liang et al. (2016)).

Rapid sand filtration provides "rapid and efficient removal of relatively large suspended particles" (Conradin et al. (2010)). Before going through filtration, the water is treated with coagulant, which allows the particles to adhere to one another and form bigger particles. After the particles are coated with coagulant and allowed to build up, the water then flows to the sand filter. As filtration proceeds, an increasing amount of pressure is required to force the water through the filter. This increase in pressure is known as head loss. Head loss is caused by the accumulation of flocs in the pores of the sand filter, thus affecting the flow of water through the filter as water molecules are forced to find an alternate path to exit the filter (Minnesota Rural Water Association (199)). When head loss becomes too high, the filter can no longer produce effluent water at the desired rate and the pressure decreases. In order to decrease head loss, the filter must be backwashed to remove the flocs that are stuck in the sand layers. "Regardless of the method of control, the filter eventually fills with suspended material" (Minnesota Rural Water Association (199)). Therefore, backwash is essential and needed to allow the filter to work at maximum capacity. Head loss should be continuously measured to help determine when the filter should be backwashed. Most engineering manuals state that filter bed expansion should be 30 to 50 percent. Realistically, a 15% to 20% expansion area will get the filters clean with the proper backwash duration (The National Environmental Services Center (2015)).

Previous Work

Previous StaRS Filter Theory teams have examined the optimal conditions to maximize efficiency of the StaRS filter. It was done by creating a smaller experimental apparatus that best resembles the stacked rapid sand filters in Agua Clara plants. The model was used to run designed experiments to examine individual variables that may be affecting the filter's performance. With additional data taken every semester, there have also been many adjustments made to the model. Specifically, previous teams have carefully examined the inlet sys-

tem, designing and testing various inlet systems with hopes to reduce head loss. Through their work, it was determined that the main cause of head loss in slotted pipes is from coagulant and clay floc build-up as residence time in the filter increased. The previous teams first tested the pipes by injecting clay water through the filters, discovering that the head loss of this experiment was insignificant. However, when a mixture of PACl, the coagulant, and clay water was put through the system, there was substantial head loss. Additionally, the team observed that a PACl-water mixture alone resulted in lower head loss. These results were graphically organized into plots that displayed a relationship between the mass of PACl injected into the filter and head loss, independent of the amount of clay. Therefore, the experiments conducted by the previous teams allowed the fall 2015 semester team to hypothesize that the mass of PACl is the determining factor of filtration performance. In conclusion, the slotted pipes design leads to clogging and head loss and thus, is not efficient.

The most recently improved design was an orifice facing downwards. During the fall semester of 2015, the team assembled the new apparatus to include the new inlet system, a small-scale flocculator, and contact chamber. The students ran experiments using the new pipe design to test its efficiency and analyze head loss. However, the team encountered problems with the new design system as it continued to cause problems by allowing sand to enter through the inlet system. This resulted in scarce data as more time was required during the cleaning process. In addition, due to a faulty PID control system, the influent turbidity varied too much, rendering a portion of the scarce data collected useless. StaRS Filter Theory Subteam (2015).

Methods and Discussion

An experimental apparatus was designed to model StaRS Filters. Experiments conducted using this apparatus were based on a constant influent turbidity value of 5 NTU and varying coagulant dosages. Data on head loss, failure time, and effluent turbidity was collected to assess the performance of sand filters in removing flocs from settled water.

ProCoDA Methods

The ProCoDA method file can be found in `StaRSTheoryUpdate.pcm`. Several states were used to control various pumps and valves for each mode of the filter.

States

- Filter: Begins experiments by pumping clay-suspended water and PACl into the filter apparatus. Open - solenoid valves A, C, E; On - clay pump, PACl pump, Influent pump.
- Backwash: Removes clay particles from the experimental apparatus. Open-solenoid valves B, D; On - influent pump.
- Calibrate pumps: Sets pump speeds for calibration. On - desired pump for calibration.

- Toggle: Tests solenoid valves individually. Open- desired solenoid valve for testing.
- Backwash Half Flow: Removes clay particles from the experimental apparatus. Operates at half flow in order to reduce sand rising as a column and to help the sand fluidize earlier. Open- solenoid valves B, D; On - influent pump.
- Backwash Toggle: Solenoid B is open and closed periodically so that the water pulses through the filter during backwash. Pulsing the water helps the sand fluidize. Open - solenoid valves B, D; On- influent pump
- Pump water - disconnect filter: Prepares the influent water for filtration by allowing PID control to adjust the clay pump until the target influent turbidity is reached and is stable. The filter is manually disconnected from the system and manual valve G is closed to prevent water from leaving the disconnected system. Open - solenoid valve A ; On - influent pump, clay pump.
- Filter - No Clay: Cleans out the flocculator and filter. When cleaning out the flocculator, the filter is disconnected from the system and manual valve G is closed. When cleaning out the filter, the filter is reconnected and manual valve G is open. Open - solenoid valves A, C, E; On - influent pump.
- Open Solenoid Valves: Pre-experimental state opens solenoid valves so that pressure sensor readings between Off and Filter states change minimally. Open - solnoid valves A, C, E.

Setpoints

- On: This setpoint corresponds to Boolean 1 and is used to turn pumps on and open solenoid valves.
- Off: This setpoint corresponds to Boolean 0 and is used to turn pumps off and close solenoid valves.
- Runtime: This setpoint corresponds to the amount of time a certain state will run until it transitions into the next state (this setpoint is used in automatic mode).

Variables

- Influent/Backwash/PACl Pump Speed: These variables uses pump control code. It has inputs of flow rate and mL/revolution. It outputs a pump speed.
- Clay Pump Speed: This variable uses Proportional-Integral-Derivative (PID) control code. It has inputs of P, I, D, a target value, and a current value. It outputs a pump speed. P is the proportional term used to compile present values of error. I is the integral term that integrates the past values of error such that the system can detect how much change in the pump speed is needed to acquire the target value. The P and I values used were 500m and 200m respectively.

- PACl Flow Rate: This variable uses chemical dosing pump speed code. It has inputs of influent flow rate, PACl stock concentration, and PACl dose concentration. It outputs a flow rate, which is used to determine the PACl pump speed.
- Turbidity: This variable uses turbidimeter code. It has an input of turbidimeter ID. It outputs the turbidity reading.

Cleaning Protocol

A cleaning protocol was formalized so that each filter run started with a clean filter, flocculator, and system tubing. Cleaning involves steps to help filter sand fluidize and clean the filter (steps 1-3, 20), clean the walls of the tubing, contact chamber, and flocculator (steps 6-11), clean the cuvettes (step 12), and prepare the system for the next filter run (steps 22 - 26). A successful backwash state is when the filter sand fluidizes completely and the system is in the Backwash state continuously without sand clogging the apparatus and preventing water flow. Vinegar is used in cleaning to reduce the pH of the water and allow the coagulant to dissolve into the water more easily. The state of the system begins with the Off state after a filter run.

1. Backwash Half Flow. Ensure that the filter bed fluidizes.
2. Backwash Toggle. Ensure that the filter bed fluidizes at the full flow rate.
3. Backwash. Run for 5 minutes, and continue backwashing if there are visible clay particles in the filter. If the filter sand has not yet fluidized, switching between Off, Backwash Half Flow, Backwash Toggle, and Backwash helps break up the sand column.
4. Off. Turn off the clay pump manually.
5. Disconnect the system at the flocculator. Close manual valve after the flocculator.
6. Pump Water- Filter Disconnect. Prime (run at full speed) the influent pump for 30 s with clean tap water to flush out particles from the tubing, contact chamber, and flocculator.
7. Replace the PACl stock tank with a tank of vinegar.
8. Prime the PACl pump to flush the contact chamber and flocculator with vinegar for 30 s.
9. Replace tank with vinegar with the tank with water. Prime PACl pump to remove vinegar from the system.
10. Off.
11. Examine the contact chamber, flocculator, and tubing and determine if it is clean. If walls have clay coated on them, disconnect the parts from system and flush them with water.
12. While cleaning the contact chamber, flocculator, and tubing, directly connect the influent turbidimeter to the filter.

13. Filter No Clay. Run clear water through the system to clean out the effluent system and turbidimeter.
14. Off. Reconnect all parts of the system.
15. Empty turbidimeter cuvettes and rinse with DI water.
16. Screw cuvettes back in and wipe outside with a Kimwipe. Do not reassemble turbidimeters yet.
17. Pump Water- Filter Disconnect. Ensure that there are no leaks from the influent cuvette.
18. Shake contact chamber to ensure there are no air bubbles in the system.
19. Off. Reconnect system at flocculator.
20. Filter No Clay. Ensure that there are no leaks from the effluent cuvette.
21. If there are no leaks, reassemble turbidimeters.
22. Backwash, if necessary, to get rid of air bubbles.
23. Filter No Clay. Run until effluent turbidity is below 0.5 NTU, indicating that residual clay and coagulant is minimal.
24. Check PACl stock tank and clay stock tank levels.
25. Open Solenoid Valves. Zero pressure sensor.
26. Filter. Start a new experiment. Turn on Automatic mode.
27. Ensure that PID control for influent turbidity properly corrects the value to 5 NTU.

First Iteration – Clay without a Flow Accumulator

The goal of the first iteration was to reassess the experimental apparatus and fix issues that previous StaRS Filtration Theory teams had. Previous teams struggled to find an inlet system that would prevent sand from entering the inlet system, but eventually decided on an open orifice design. However, the design was not able to prevent sand from flowing in through the orifice. To solve the issue, the team focused on manipulating the water pump with the primary goal of preventing air from entering the system, which in turn caused sand to enter through the inlet system during backwash. The team removed the flow accumulator in conjunction with the three-roller pump and introduced a six-roller pump. The flow accumulator, a device that allows the water level in the apparatus to fluctuate, was used to reduce pulsing in the apparatus, but it provided a non-pressurized system in which sand was able to exit the filter during backwash. However, removing the flow accumulator caused pulsing due to the peristaltic pump, so the team introduced a six-roller pump to reduce pulsing. Finally, a 600 RPM motor was used with the six-roller pump to ensure that air did not enter the system.

The flocculator was also redesigned. A tube of 0.175 mm ($\frac{1}{8}$ in) diameter was implemented to reduce coagulant accumulation in the tubes of the flocculator.

With these adjustments, the team ran five experiments at an influent turbidity of 5 NTU and PACl dosages of $0.2 \frac{\text{mg Al}}{\text{L}}$, $0.65 \frac{\text{mg Al}}{\text{L}}$, $1.1 \frac{\text{mg Al}}{\text{L}}$, $1.55 \frac{\text{mg Al}}{\text{L}}$, and $2.0 \frac{\text{mg Al}}{\text{L}}$ as well as a control group at $0 \frac{\text{mg Al}}{\text{L}}$.

The team added humic acid to the clay stock. This was done because the control experiment of clay without PACl did not allow for failure. Humic acid along with clay would allow the experiments to model AguaClara plants because it would represent organic matter. The team then ran experiments at PACl dosages of $0.2 \frac{\text{mg Al}}{\text{L}}$, $0.65 \frac{\text{mg Al}}{\text{L}}$, $1.1 \frac{\text{mg Al}}{\text{L}}$, $1.55 \frac{\text{mg Al}}{\text{L}}$, and $2.0 \frac{\text{mg Al}}{\text{L}}$ as well as a control group at $0 \frac{\text{mg Al}}{\text{L}}$.

Experimental Apparatus 1

The apparatus was originally built in Fall 2015 and the overall design has not changed significantly (StaRS Filter Theory Subteam (2015)). However, a new flocculator was built to have a velocity gradient, G , of $200 \frac{1}{s}$. The resulting dissipation rate, tubing size, length, and residence time were calculated. The team found a residence time of 23 seconds with a length of 3 meters and a tubing size of $\frac{1}{8}$ in. The calculations can be found in the Tube Flocculator Design file.

To reduce pulsing in the system, the water inlet pump was replaced by a six-roller pump on a 600 RPM motor in order to prevent sand from entering the inlet pipe. The team originally had the six-roller pump on a 100 RPM motor. The cartridge was not tight enough on the tubing and the six-roller pump had a gear reduction attached. Therefore, the water was not properly pumped into the system and the pump only ran at a sixth of the desired rate. In order to account for the resulting gear reduction, the team replaced the 100 RPM motor with a 600 RPM motor, thus adjusting and increasing the RPM received by the six-roller pump by a factor of six. Also the team used the tighteners on the top of the cartridges to allow the pump to properly push the water through the tubes.

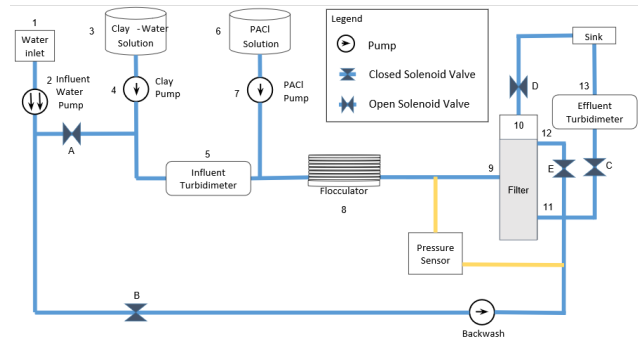

Figure 2: The schematic of the experimental apparatus during Filter state

The water enters the apparatus from the water inlet, and is then pumped by the influent water six-roller pump. The stored clay-water solution is pumped into the influent water to model a raw water solution of 5 NTU. Then the influent turbidimeter reports the turbidity of the solution and the value is passed to ProCoDA to ensure that the solution remains at 5 NTU. After passing the

influent turbidimeter, the experimental PACl solution is added. As the PACl and clay are in the flocculator, flocs become correct size. The solution then enters the filter through the inlet pipe. The filter has about a 20 cm high sand bed with sand that was sieved between sieve numbers 30 and 35. After passing through the filter, the water exits through two outlet pipes which then leads to the effluent turbidimeter. The effluent turbidimeter records the turbidity of the filtered water. The water is then sent to the exit. During backwash, the B and D solenoid valves are opened and allow water to enter the filter from the bottom and flow through the top. This allows the sand to expand so that particles trapped in the sand can flow upwards and through the exit.

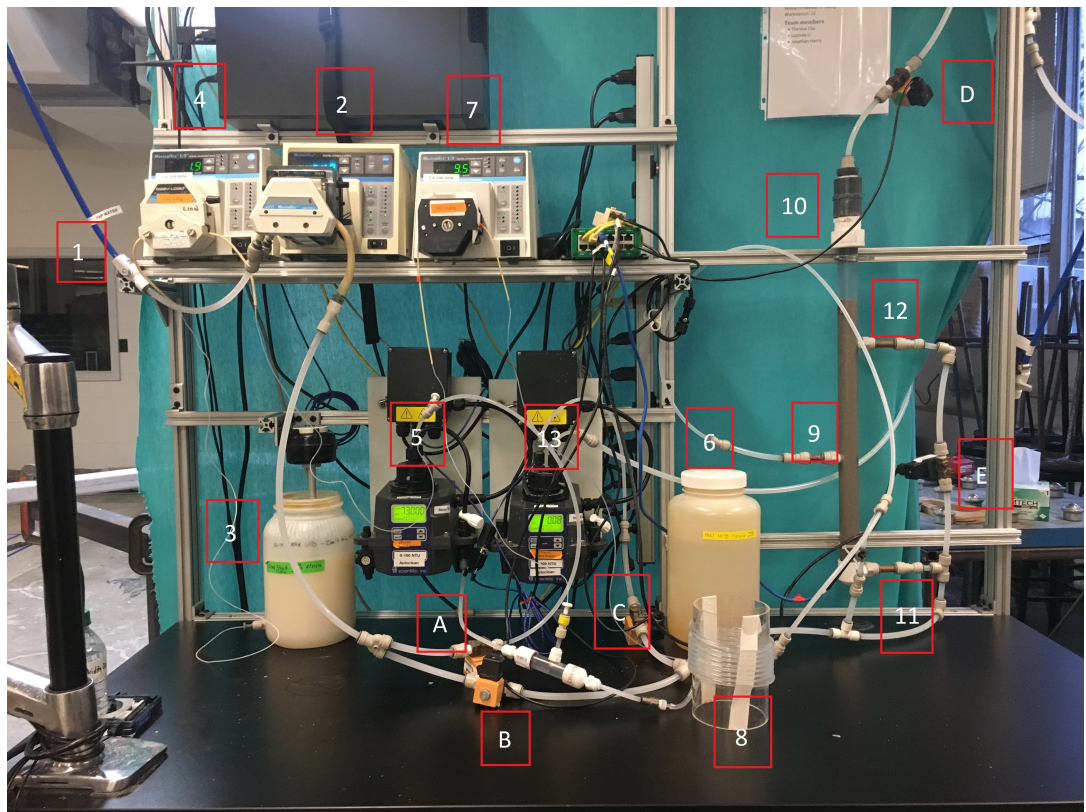

Figure 3: The experimental apparatus in lab with labeled parts. Each part corresponds with the number or letter in Figure 2.

ProCoDA Methods

The original ProCoDA methods are as found in the main section of the Methods for running an experiment. The ProCoDA methods for this iteration did not include the states of Backwash Toggle and Open Solenoid Valves.

Procedure 1

Experimental design was motivated by the goal of a mathematical model comparing coagulant dose and filter performance. The experiments were conducted

based on an influent turbidity of 5 NTU. The influent turbidity value was constant throughout the experimental procedure, while the influent PACl dose varied with each experiment. Five PACl doses were tested: $0.2 \frac{\text{mg Al}}{\text{L}}$, $0.65 \frac{\text{mg Al}}{\text{L}}$, $1.1 \frac{\text{mg Al}}{\text{L}}$, $1.55 \frac{\text{mg Al}}{\text{L}}$, $2 \frac{\text{mg Al}}{\text{L}}$. Each experiment was conducted for 12 hours, followed by a thorough cleaning cycle.

Several issues were discovered in operating the apparatus to run properly. Disconnecting tubes during filtration caused sand to leave the filter through the inlet pipe. When there was air in the system, backwashing the filter only caused sand to exit as well.

Results and Analysis 1

The head loss and effluent turbidity data from the experiments with $0.2 \frac{\text{mg Al}}{\text{L}}$, $0.65 \frac{\text{mg Al}}{\text{L}}$, $1.1 \frac{\text{mg Al}}{\text{L}}$, $1.55 \frac{\text{mg Al}}{\text{L}}$, and $2.0 \frac{\text{mg Al}}{\text{L}}$ PACl are plotted in Figures 4 and 5. In the raw data, there were increasing deviations from the mean head loss over time that is caused by pulsing of the inlet water. However, since the amplitude from the mean is approximately the same magnitude at each time point, the overall change does not significantly affect the head loss trend of linear increase. The data was smoothed to minimize this pulsing in the visualization and better display the true head loss trend.

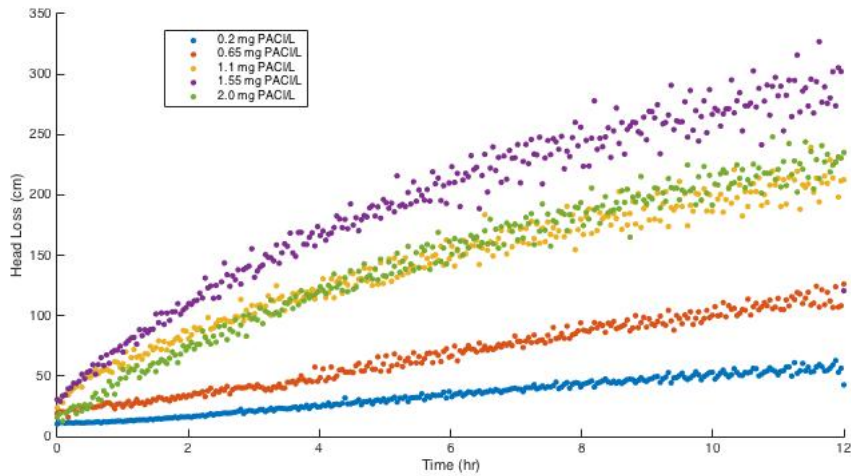

Figure 4: Head Loss over time

The head loss data in Figure 4 shows linear increases in head loss over time for the two lowest PACl dosages and a logarithmic increase for the remaining, higher dosages. The filter run with a PACl dosage of $0.2 \frac{\text{mg Al}}{\text{L}}$ has an increase of 4.2 cm of head loss per hour. After twelve hours, the change in head loss was approximately 50 cm. The filter run at $0.65 \frac{\text{mg Al}}{\text{L}}$ shows a linear increase in head loss at a rate of about 8.5 cm per hour, resulting in about 100 cm of head loss over 12 hours. The filter run at $1.1 \frac{\text{mg Al}}{\text{L}}$ shows a logarithmic increase in head loss with about 200 cm of head loss over 12 hours. For the first hour, this experiment run had a linear increase in head loss of 11.5 cm per hour. At 1.55

$\frac{\text{mg Al}}{\text{L}}$, there is a logarithmic increase in head loss resulting in about 300 cm of head loss over 12 hours. In the first hour, the rate of head loss was 11.8 cm per hour. The filter run at $2.0 \frac{\text{mg Al}}{\text{L}}$ shows a logarithmic increase in head loss resulting in about 240 cm of head loss over 12 hours. The rate of head loss over the first hour was 10.6 cm per hour. By comparing the rates of head loss per hour in the linear graphs and that of the logarithmic curves in the first hours of each experiment run, it was observed that the higher dosages resulted in a steeper increase in head loss before leveling off. The logarithmic curves in head loss represented by the graphs of the $1.1 \frac{\text{mg Al}}{\text{L}}$, $1.55 \frac{\text{mg Al}}{\text{L}}$, and $2.0 \frac{\text{mg Al}}{\text{L}}$ filter runs indicate that as the PACl dosage increases, head loss will increase rapidly until the rate of increase in head loss decreases. The decrease in the rate of head loss increase is caused by the physical entrapment of coagulated particles in the filter. When pore space in the filter is occupied by particles, influent water flowing through will lose energy in order to move through the filter. When the filter reaches a certain particle density, the filter will reach a maximum head loss that the influent water can endure to flow through the filter.

Adding more PACl with the same influent turbidity of 5 NTU demonstrates that a higher PACl dosage results in higher head loss rates. The increase in mass added to the filter results in smaller pores in which the water can travel through, increasing head loss more quickly.

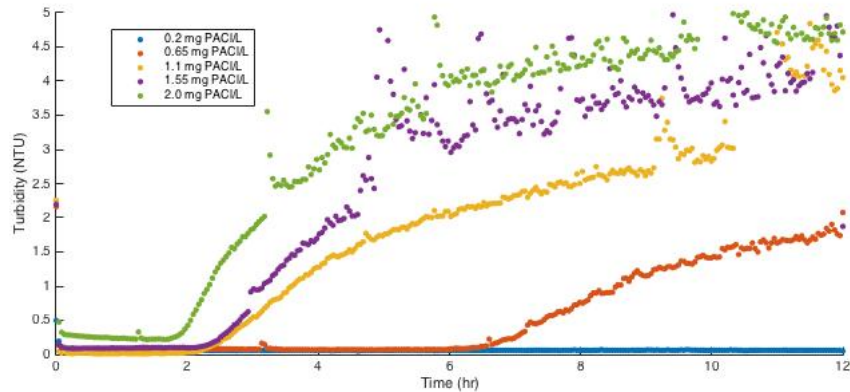

Figure 5: Effluent Turbidity over time

The effluent turbidity in Figure 5 shows that after 12 hours of filtration failure occurred in the experiments with higher PACl dosages. Filter failure is a phenomenon where effluent turbidity begins to increase sharply indicating the time at which clay particles leave the filter instead of getting trapped in the sand pores. Examining Figure 5, failure did not occur in the $0.2 \frac{\text{mg Al}}{\text{L}}$ PACl dosage. However, after 6 hours of filtration, failure occurred in the $0.65 \frac{\text{mg Al}}{\text{L}}$ PACl dosage. At $1.1 \frac{\text{mg Al}}{\text{L}}$, failure occurred after 2 hours. The failure time further decreased for $1.55 \frac{\text{mg Al}}{\text{L}}$, as failure occurred just after two hours, slightly before the $1.1 \frac{\text{mg Al}}{\text{L}}$ reached failure. For the $2.0 \frac{\text{mg Al}}{\text{L}}$, failure occurred just before 2 hours. The effluent turbidity graph shows that the filter failed at the failure times for the higher PACl dosages because the filter did not continue to produce clean water. The higher PACl dosages led to a decrease in failure

time for the filter. Since there is a higher PACl dosage, the filter is clogged with more particles more quickly because there is a greater mass entering the filter. The shear force on the particles is greater than the forces between the clay and the coagulant, so the particles cannot stick to the coagulant on the sand and failure occurs.

Second Iteration - Clay with a Flow Accumulator

The experimental apparatus was modified to better model field conditions of water flowing through the sand. A flow accumulator was added to reduce pulsing from the peristaltic pump, a check valve was added to prevent sand from leaving the filter, and an on/off switch for the PACl pump to automatically shut off the injection of PACl with the rest of the system.

Given the results of the first iteration and the various PACl dosages from $0.2 \frac{\text{mg Al}}{\text{L}}$ to $2.0 \frac{\text{mg Al}}{\text{L}}$, a new set of experiments was designed to better test the limits of the filter. With the same influent turbidity of 5 NTU and the filter apparatus, new coagulant dosages were tested. Since the filter did not fail after 12 hours for a $0.2 \frac{\text{mg Al}}{\text{L}}$ PACl dosage, the run time was extended to 24 hours. As a control experiment, a filter run with no coagulant was conducted. The control experiment of $0 \frac{\text{mg Al}}{\text{L}}$ did not fail after 24 hours. Since the filter did not fail without coagulant, the experiments with this apparatus stopped because the team could not effectively understand the performance of the filter.

Experimental Apparatus 2

The head loss graphs produced for the first iteration of experiments indicated that there are significant oscillations caused by the pulsing of inlet water. To prevent this effect from inhibiting precise analysis of the data in future experiments, a flow accumulator was added to the experimental apparatus to decrease the vibrations caused by pulsing. In addition, a check valve that only allows water to flow in one direction, was added to discourage the sand from entering the inlet system. Another alteration made to the apparatus was in adding a manual valve after the flocculator. The manual valve prevents air from entering the filter when the system is disconnected at the flocculator before starting an experiment. Finally, an on/off switch was introduced to automatically turn off the PACl pump after experiments. Previously, the PACl pump required manual shut down after experiments which often led to wasted PACl floating in the system. The on/off switch added to the PACl pump allowed ProCoDa to turn off the pump when experiments were over.

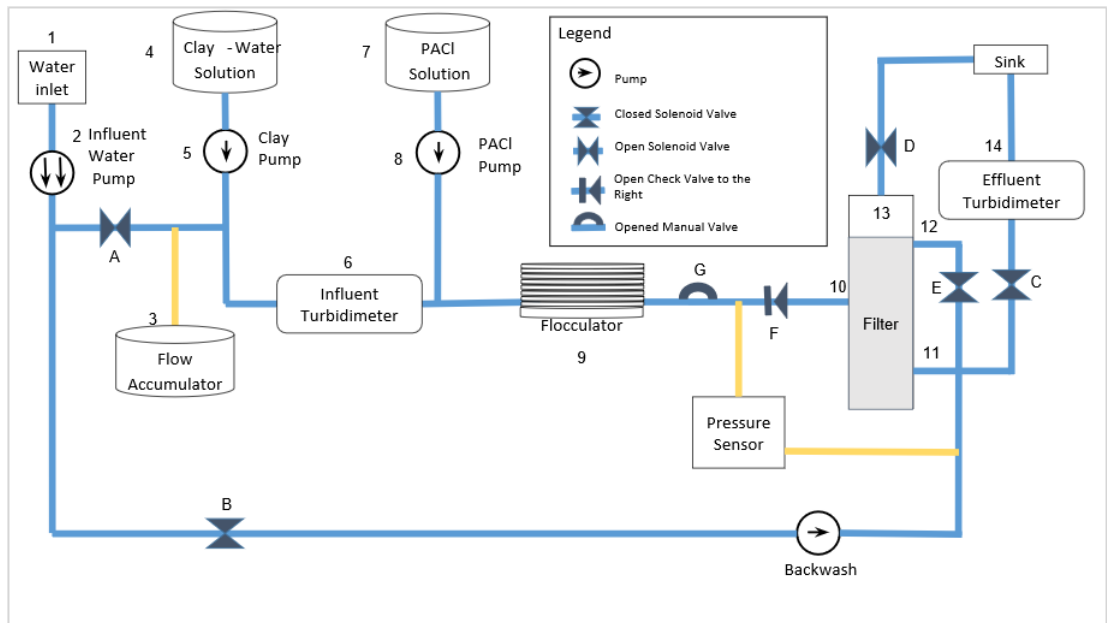

Figure 6: The schematic of the experimental apparatus during filter state.

The schematic has labels that coincide with the labeled picture of the experimental apparatus.

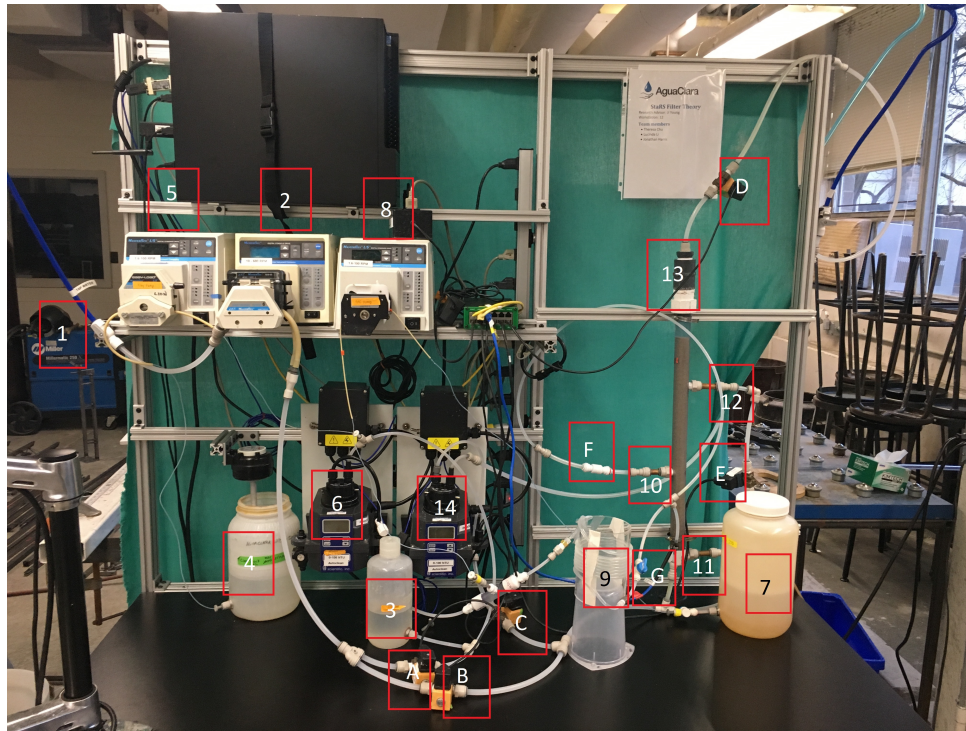

Figure 7: The experimental apparatus in lab with labeled parts. Each part corresponds with the number or letter in Figure 2.

ProCoDA Methods 2

Several new states were added to the ProCoDA methods after Iteration 1 in order to aid with cleaning and preparing the filter for the next experiment, which are included in the main methods section. The use of these states are detailed in the Cleaning Protocol. The states added were: Backwash Half Flow, Backwash Toggle, Pump Water - Disconnect Filter, added Filter - No Clay.

Procedure 2

The influent turbidity was held constant at 5 NTU. A range of PACl dosages were tested from $0 \frac{\text{mg Al}}{\text{L}}$ to $0.2 \frac{\text{mg Al}}{\text{L}}$, including $0 \frac{\text{mg Al}}{\text{L}}$, $0.1 \frac{\text{mg Al}}{\text{L}}$ and $0.2 \frac{\text{mg Al}}{\text{L}}$. These experiments were conducted for 24 hours so that the full life-cycle of a filter can be accounted for in the head loss and effluent turbidity data. After each experiment, the apparatus was cleaned following the general cleaning procedure found in the Methods section.

Results and Analysis 2

The head loss and effluent turbidity data from the experiments with $0 \frac{\text{mg Al}}{\text{L}}$, $0.2 \frac{\text{mg Al}}{\text{L}}$, and $0.01 \frac{\text{mg Al}}{\text{L}}$ PACl are plotted in Figures 8 and 9.

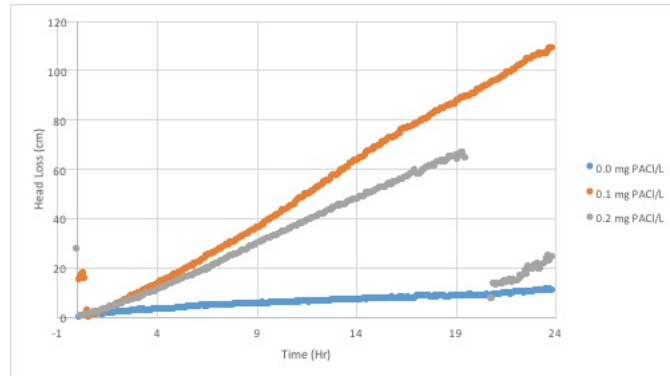

Figure 8: Head Loss over time

The head loss data in Figure 8 shows linear increase in head loss over time for the three PACl dosages. The filter run with the PACl dosage of $0.2 \frac{\text{mg Al}}{\text{L}}$ had a disturbance that caused errors to the pressure sensor. The reason for the disturbance is currently unknown, but it is believed something collided with the work station and moved the pressure sensor slightly. The slope of the data after the interference remained consistent with the data before, thus showing that there was nothing wrong with the experiment, but rather a problem with the pressure sensor. Overall, the rates of head loss remain consistent for the $0.1 \frac{\text{mg Al}}{\text{L}}$ and $0.2 \frac{\text{mg Al}}{\text{L}}$ PACl dosages. The $0 \frac{\text{mg Al}}{\text{L}}$ had an increase of 0.42 centimeters of head loss per hour. After 24 hours, the change in head loss was approximately 10 centimeters. The $0.1 \frac{\text{mg Al}}{\text{L}}$ had a 110 centimeter increase in 24 hours. In other words, it had an increase of 4.6 centimeters of head loss per hour.

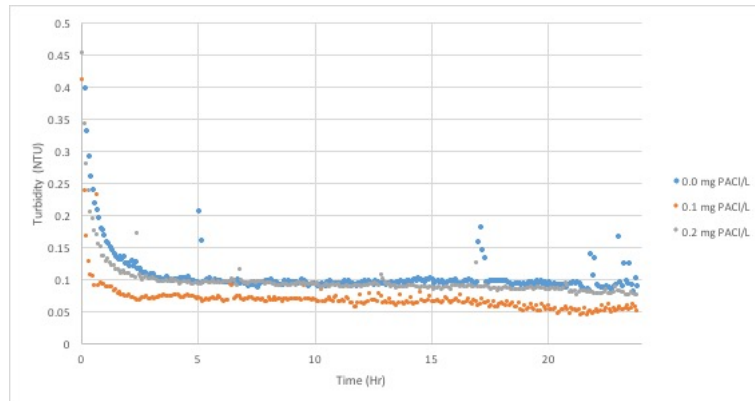

Figure 9: Effluent Turbidity over time

The effluent turbidity in Figure 9 shows that after 24 hours of filtration, breakthrough did not occur in the $0 \frac{\text{mg Al}}{\text{L}}$ PACl dosage, $0.1 \frac{\text{mg Al}}{\text{L}}$ PACl dosage and the $0.2 \frac{\text{mg Al}}{\text{L}}$ PACl dosage. The $0.1 \frac{\text{mg Al}}{\text{L}}$ consistently produced water with lower turbidity compared to the $0.2 \frac{\text{mg Al}}{\text{L}}$ and $0 \frac{\text{mg Al}}{\text{L}}$. The $0.2 \frac{\text{mg Al}}{\text{L}}$ and the $0 \frac{\text{mg Al}}{\text{L}}$ produced the same quality of water. Since the filter was not fully clogged

in 24 hours for the $0 \frac{\text{mg Al}}{\text{L}}$, the team added humic acid to the clay stock to model field conditions of water that has organic matter.

Third Iteration - Clay and Humic Acid with a Flow Accumulator

This set of experiments tests the filter using influent water that has clay and humic acid. The humic acid was added because experimentation with no coagulant and only clay resulted in no filter failure, so the filter would never actually be clogged because of the high turbidity of the influent water alone. The influent containing humic acid and clay will better model conditions similar to surface water because it acts as organic matter found in surface water. The ratio of clay and humic acid was found so that there would be 1 mg/L of humic acid in the influent water reaching the filter. The same range of PACl dosages was tested: $0.0 \frac{\text{mg Al}}{\text{L}}$, $0.2 \frac{\text{mg Al}}{\text{L}}$, $0.65 \frac{\text{mg Al}}{\text{L}}$, $1.1 \frac{\text{mg Al}}{\text{L}}$, $1.55 \frac{\text{mg Al}}{\text{L}}$, and $2.0 \frac{\text{mg Al}}{\text{L}}$.

Experimental Apparatus 3

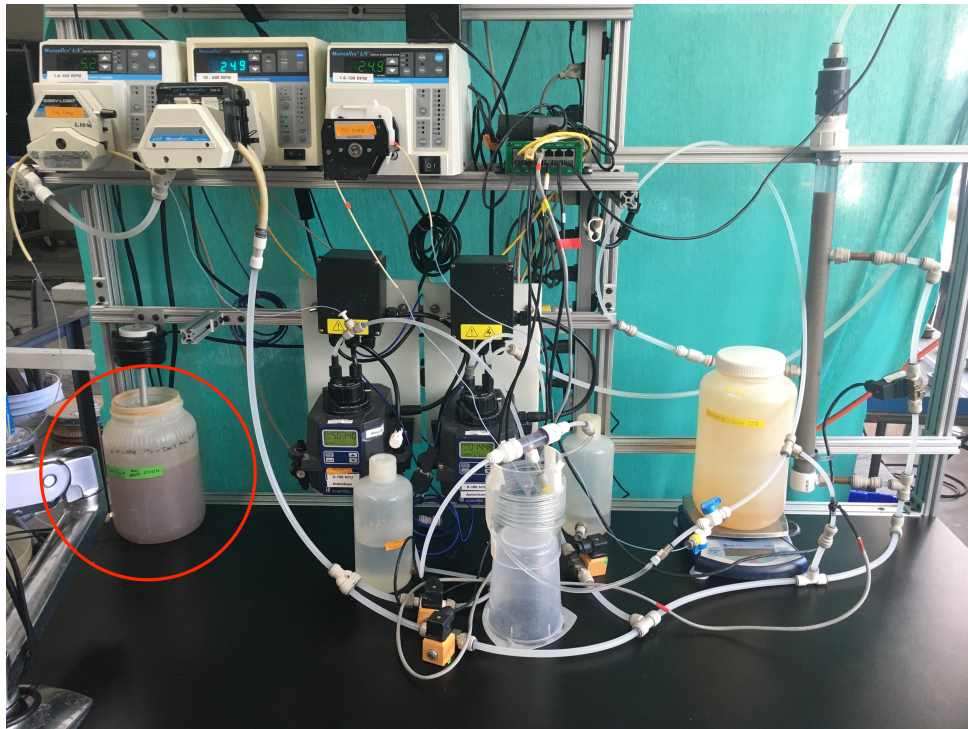

Figure 10: The experimental apparatus in lab with the humic acid and clay mixture circled.

Procedure 3

The influent turbidity was held constant at 5 NTU. However, instead of the clay-water mixture previously used, a mixture of clay, water, and humic acid was prepared and incorporated into the system. Using the new mixture, a range

of PACl dosages was tested from $0 \frac{\text{mg Al}}{\text{L}}$ to $2.0 \frac{\text{mg Al}}{\text{L}}$, including $0 \frac{\text{mg Al}}{\text{L}}$, $0.2 \frac{\text{mg Al}}{\text{L}}$, $0.65 \frac{\text{mg Al}}{\text{L}}$, $1.1 \frac{\text{mg Al}}{\text{L}}$, $1.55 \frac{\text{mg Al}}{\text{L}}$ and $2.0 \frac{\text{mg Al}}{\text{L}}$.

These experiments were conducted for either 12 or 24 hours so that the full life-cycle of a filter might be seen in the head loss and effluent turbidity data. The $0 \frac{\text{mg Al}}{\text{L}}$ and $1.1 \frac{\text{mg Al}}{\text{L}}$ experiments had a run time of 12 hours while the $0.2 \frac{\text{mg Al}}{\text{L}}$, $0.65 \frac{\text{mg Al}}{\text{L}}$, $1.55 \frac{\text{mg Al}}{\text{L}}$ and $2.0 \frac{\text{mg Al}}{\text{L}}$ experiments had a run time of 24 hours. The team expected a failure time before 12 hours for this set of experiments and decided to run the $0 \frac{\text{mg Al}}{\text{L}}$ and $1.1 \frac{\text{mg Al}}{\text{L}}$ experiments for 12 hours. However upon further data analysis, the team decided that changing the run time to 24 hours could demonstrate a trend as run time approaches a large number, thus causing the variation in experiment run times.

After each experiment, the apparatus was cleaned following the general cleaning procedure found in the Methods section. However, a change was made to the cleaning procedure. Instead of disconnecting the system at the flocculator after effluent turbidity reaches a value below 0.5 NTU and right before PID control, the procedure removed the step and required the team to turn off the system, zero the pressure sensor with the system connected at the flocculator, then start the experiment. With this adjustment, the pressure in the system immediately after the experiment started was the same as the pressure before the experiment started. The previous cleaning procedure required the team to disconnect the system at the flocculator for PID, reconnect the system at the flocculator when influent turbidity remains around 5 NTU, turn off the system, zero the pressure sensor, open the manual valve to the filter, and finally start the experiment on the ProCoDA Filter state. These steps in the procedure created shifted head loss graphs up because the pressure sensor was zeroed when the manual valve to the filter was still closed. When the valve was opened to start the experiment, the flow of water into the filter caused a significant change in pressure in the system, which affected the initial pressure reading immediately after the experiment started. This change in pressure was observed in the previous graphs of the raw head loss data and was corrected by normalizing all graphs with unusually high pressure readings. The new cleaning procedure solved this issue and allowed for a properly zeroed initial head loss.

Results and Analysis 3

Head Loss

The head loss curves for each experiment were consolidated into Figure 11 below.

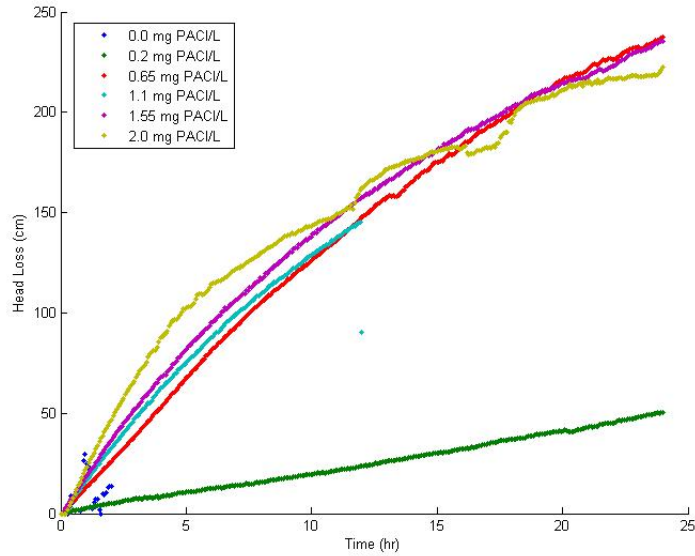

Figure 11: Head Loss over time

The head loss in the control experiment, $0 \frac{\text{mg Al}}{\text{L}}$ had a head loss of around 0 centimeters. This indicates that without PACl in the system, head loss was not affected at all by the clay-humic acid mixture. In the $0.2 \frac{\text{mg Al}}{\text{L}}$ experiment, the initial head loss immediately after the experiment started was 24.36 centimeters, but the final head loss after 24 hours was 74.28 centimeters. In short, there was a head loss difference of 49.92 centimeters throughout the experiment. The initial head loss in the $0.65 \frac{\text{mg Al}}{\text{L}}$ experiment was 31.73 centimeters and the final head loss was 266.86 centimeters resulting in a head loss difference of 235.13 centimeters. In the $1.1 \frac{\text{mg Al}}{\text{L}}$ experiment, the initial head loss was 20.42 centimeters and the final head loss was 165.65 centimeters. This was a head loss difference of 145.23 centimeters. In the $1.55 \frac{\text{mg Al}}{\text{L}}$ experiment, the initial head loss was 13.27 centimeters while the final head loss was 248.55 centimeters resulting in a head loss difference of 235.28 centimeters. In the final experiment with a $2.0 \frac{\text{mg Al}}{\text{L}}$ dosage, the initial head loss was 2.86 centimeters and the final head loss was 168.32 centimeters. Or, a head loss difference of 165.46 centimeters. With these results, there was no significant trend observed in head loss in correspondence to PACl dosage. However, the head loss curves for the higher PACl dosages demonstrate that after each experiment reaches filter failure, head loss converges to the same value along the same trend.

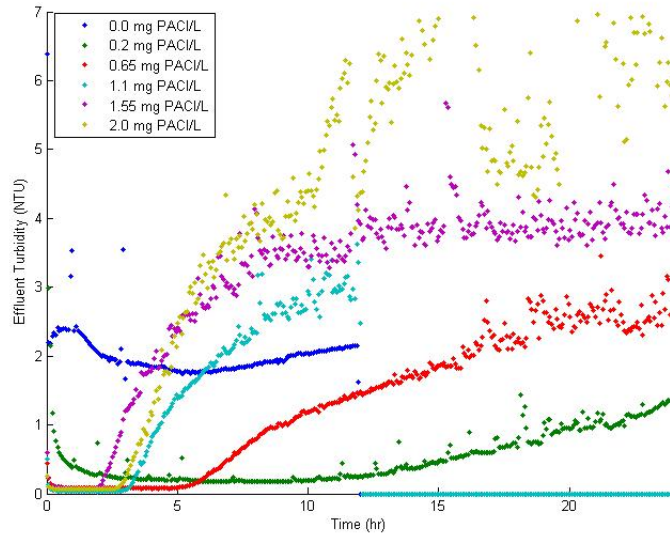

Figure 12: Effluent Turbidity over time

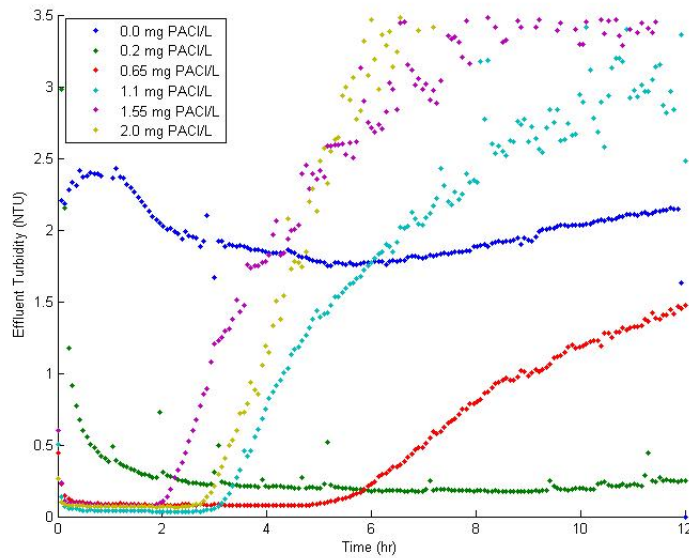

Figure 13: Effluent Turbidity over time, zoomed in on failure times

The effluent turbidity in Figure 12 shows that after 24 hours of filtration. The control experiment of $0 \frac{\text{mg Al}}{\text{L}}$ instantly failed. However, while the higher PACl dosages of $0.65 \frac{\text{mg Al}}{\text{L}}$, $1.1 \frac{\text{mg Al}}{\text{L}}$, $1.55 \frac{\text{mg Al}}{\text{L}}$, and $2.0 \frac{\text{mg Al}}{\text{L}}$ produced cleaner water at approximately 0.1 NTU, the $0.2 \frac{\text{mg Al}}{\text{L}}$ dosage produced water at approximately 0.2 NTU. The $0.2 \frac{\text{mg Al}}{\text{L}}$ took approximately 11 hours to fail whereas

the $1.55 \frac{\text{mg Al}}{\text{L}}$ failed in approximately 2 hours. There was a 9 hour difference between these two PACl dosages. The $0.2 \frac{\text{mg Al}}{\text{L}}$ continued to be the most efficient PACl dosage based on time to failure. As more PACl was added, time to failure generally decreased, except for $2.0 \frac{\text{mg Al}}{\text{L}}$ which had a later failure time than that of $1.55 \frac{\text{mg Al}}{\text{L}}$. The team does not know why this is the case and will investigate further to see why the data from this PACl dosage does not follow the general trend found in the other PACl dosages.

pC*

pC* was used as a metric for measuring filter performance and accounting for the variability in influent turbidity, as show in Equation 14

$$pC^* = -\log \frac{\text{Effluent Turbidity}}{\text{Influent Turbidity}} \quad (1)$$

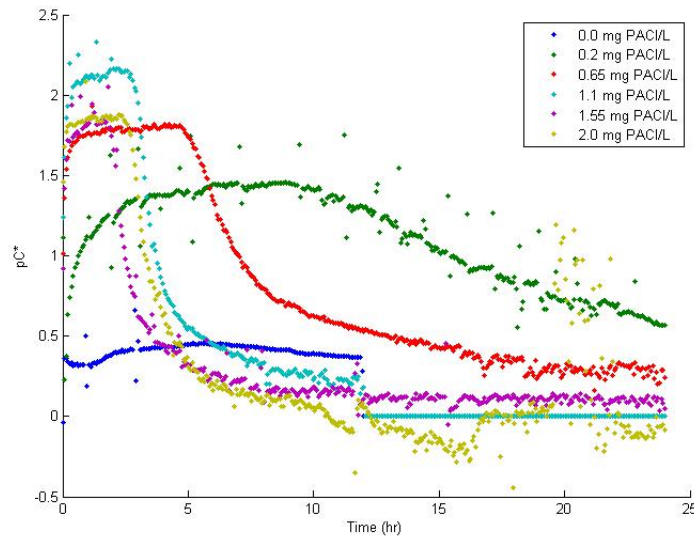

Figure 14: The pC* over time

The pC* shows the performance of the filter. Similar to the effluent turbidity graph in Figure 9 the 1.1 mg PACl/L produced the cleanest water compared to the other PACl dosages.

Performance by Coagulant Mass

Instead of plotting filter performance metrics by time, head loss, effluent turbidity, and pC* were plotted against the amount of coagulant that had passed through the filter. The amount of coagulant that had accumulated was found by multiplying the coagulant concentration by the system flow rate and the amount of time between each data point.

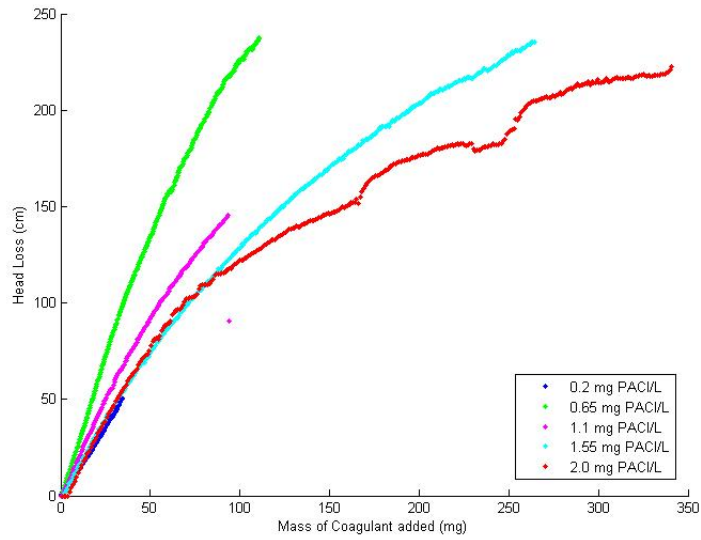

Figure 15: Head loss vs. accumulated mass of coagulant

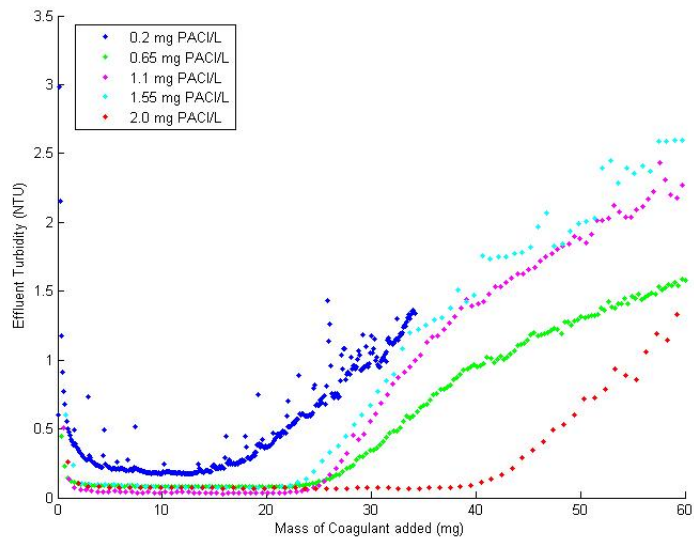

Figure 16: Effluent turbidity vs. accumulated mass of coagulant, scaled to show differences between different dosages

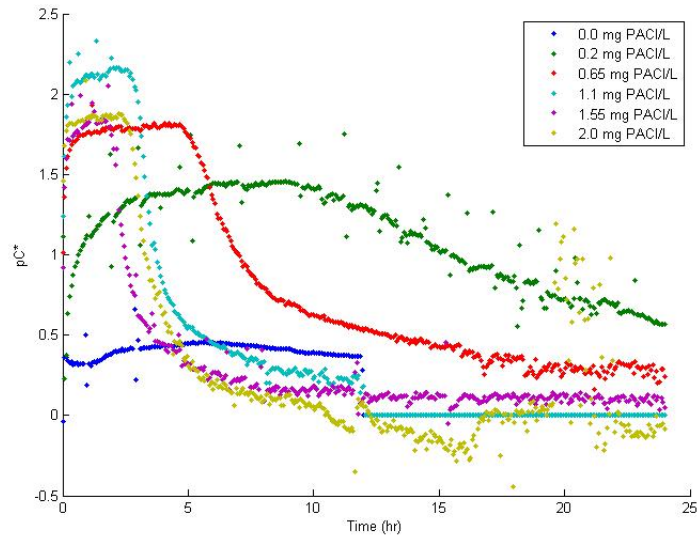

Figure 17: pC^* vs. accumulated mass of coagulant

These plots demonstrate that the amount of coagulant accumulated in the filter affects when failure occurs. The failure points get closer together based on the amount of coagulant amassed in the sand, which supports the hypothesis that the remai

Time to Failure

Each coagulant dosage resulted in a significantly different run time until failure, plotted in Figure 18. The failure time was determined as the point when the effluent turbidity began to increase rapidly above the filtered water turbidity.

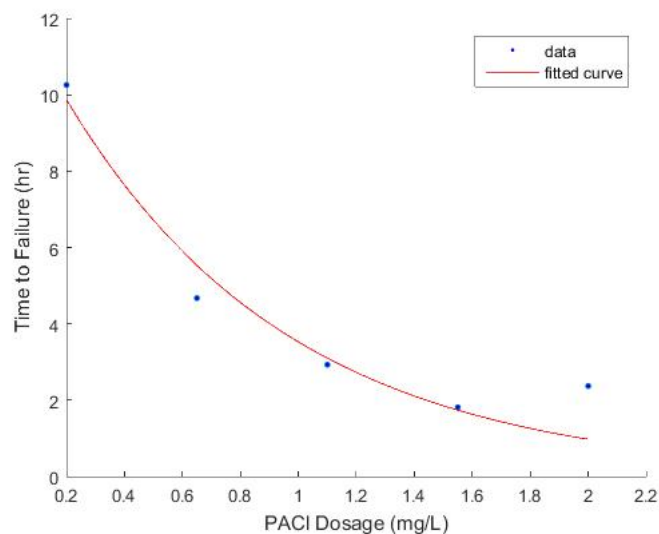

Figure 18: Failure Time

As the amount of coagulant increased, the time until the filter failed decreased. The increasing amount of coagulant in the filter led to the pores in the filter sand being filled more quickly with flocs of coagulant and clay. Thus, adding more coagulant results in a faster failure time. However, the experiment with $2.0 \frac{\text{mg Al}}{\text{L}}$ of PACl resulted in an later failure time than expected, because its failure time was later than that of the $1.55 \frac{\text{mg Al}}{\text{L}}$. This experiment should be conducted again to test whether this failure time is accurate.

Fourth Iteration - The failure of PACl, PID, and clay stock along with the creation of a new filter

As the team continued to run experiments, issues were encountered that hindered the team from being able to run an efficient experiment. First, after running a PACl dosage of 2.0 experiment for 24 hours, the team could see that coagulant did not go into the apparatus because the stock solution did not lose enough PACl. The team realized that there was a problem with the tubing from the PACl stock to the pump, and decided to replace the tubing. Also, the team added a mass measuring device to see the loss of PACl over time to make sure that the right amount of PACl is constantly leaving the stock solution. Then the team ran other experiment where PID did not work due to the influent turbidity constantly reading very dirty water. The dirt in the water never left the cuvette and therefore clay and humic acid were not added during the experiment. The team could not determine the reason for this failure and decided to run the experiment again. After 6 hours on run time, PID failed again. The team decided to clean out the raw water stock of clay and humic acid and remake it using DI water. Then the team ran other experiment with the new raw water stock and tubing for the PACl stock, but the experiment failed again because of PID. The team decided to change the P value from 0.6 to 0.3 because it is believed that PID was too reactive to changes in the influent turbidity.

The issue of the sand bed rising during backwash led the team to have to hit the filter with a hammer. The filter sustained damages which led the filter to break. Therefore, a new filter had to be built. The team used the conditions and lengths of the old filter to create the new filter. The only difference between the two filters is that the overall height of the filter changed from 61 centimeters to 71 centimeters. The team did this to allow the bed of sand to fully expand. The original calculations for the expansion of the bed was 40 cm, however there was more sand in the filter than in the calculations and therefore, the sand could not fully expand. The additional length of the filter allowed the bed to expand entirely. The team has not ran any experiments with the new apparatus, it will be used for future experiments.

Conclusions

For the set of experiments with only clay and no flow accumulator, data showed that coagulant dosage has a significant effect on head loss and effluent turbidity. Head loss increases at a greater rate with a higher coagulant dosage. The $2.0 \frac{\text{mg Al}}{\text{L}}$ coagulant dosage resulted in about five times the overall head loss compared to the $0.2 \frac{\text{mg Al}}{\text{L}}$ coagulant dosage. Increasing the coagulant dosage does not necessarily improve filter performance either. Having an influent turbidity of 5 NTU, the effluent turbidity for each experiment was similar for the first hour or until break through. Throughout the run time, the lower coagulant dosage of $0.2 \frac{\text{mg Al}}{\text{L}}$ continued to produce water with a turbidity of less than 0.1 NTU. However, as the PACl dosages increased, the failure time decreased. The $2.0 \frac{\text{mg Al}}{\text{L}}$ dosage began to fail after 1.5 hours, which was evident in the continuing increase in turbidity of up to 5 NTU.

The $0.2 \frac{\text{mg Al}}{\text{L}}$ and $0.1 \frac{\text{mg Al}}{\text{L}}$ experiments were then conducted over 24 hours with hopes to demonstrate the effects of the coagulant dosage over a longer time. For both dosages, failure time did not occur within 24 hours. However, even with these lower PACl dosages effluent turbidity remained around 0.1 NTU. Thus, these results may indicate that lower PACl dosages do not necessarily result in less efficient filter performance. Instead, the lower PACl dosages reached a similar effluent turbidity without failing for over 24 hours. However, the experiment with no coagulant added and only clay in the influent demonstrate that the filter never actually fails over the 24 hour period. The filter was not clogging quickly enough for this set of experiments to show the effect of clay on filter performance, but only the effect of coagulant.

The set of experiments with clay and humic acid show that the allowable filter run time decreases with an increasing amount of coagulant. The experiment without coagulant demonstrated that the clay and humic acid mixture effectively clogs the filter, as the filter only produces water over 2 NTU. The following experiments with increasing coagulant dosages also showed a decrease in failure time of the filter. The experiment with the dosage of $2.0 \frac{\text{mg Al}}{\text{L}}$ should be conducted again to test if the failure time is truly longer than that of the $1.55 \frac{\text{mg Al}}{\text{L}}$ experiment.

Future Work

In future research, experiments will be repeated to collect more data and see if results are consistent. Also, the head

References

- Conradin, K., Spuhler, D., and Kropac, M. (2010). Coagulation-Flocculation | SSWM.
- Liang, L., Tan, J., Peng, Y., Xia, W., and Xie, G. (2016). The role of polyaluminum chloride in kaolinite aggregation in the sequent coagulation and flocculation process. *Elsevier*, 468:57–61.
- Minnesota Rural Water Association (199). MN Water Works Mnl.
- StaRS Filter Theory Subteam (2015). StaRS Filter Theory - AguaClara - Dashboard.
- The National Environmental Services Center (2015). Tech Brief Fact Sheets - Drinking Water.
- Weber-Shirk, M. (2015). Flocculation Model.

Semester Schedule

Task Map

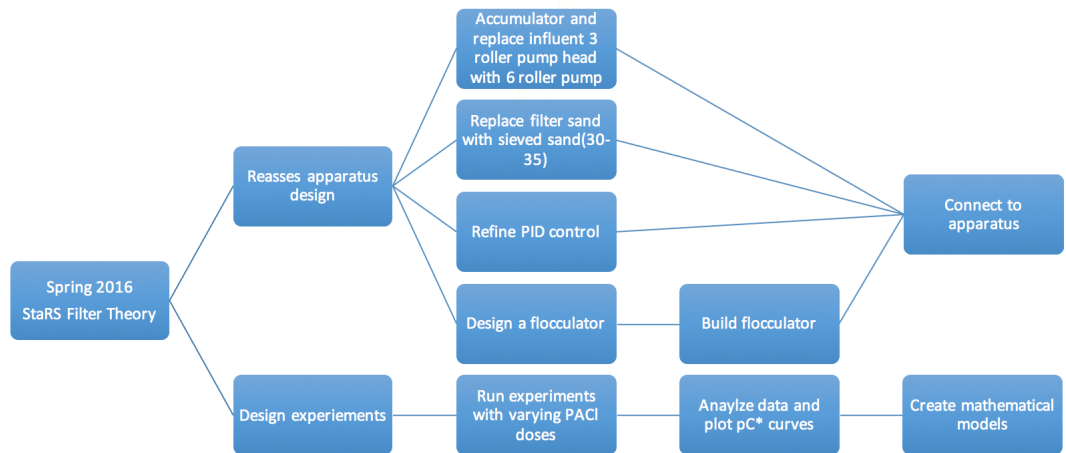

Figure 19: Task Map

Task List

1. Sieve sand/(2/8/16) - Lucinda. Sieve sand from sieve numbers 30 to 35 and replaced filter sand. - Completed.
2. Clean experimental apparatus/(2/10/16) - Jonathan. Clean the apparatus of all excess sand, clay, and coagulant. Clean contact chamber. - Completed.
3. Make PACl/(2/10/16) - Lucinda. Make stock concentration of PACl for running experiments. - Completed.
4. Make clay stock/(2/17/16) - Jonathan. Make stock concentration of clay for running experiments. - Completed.
5. Redesign apparatus/(2/19/16)- Theresa. Redesign apparatus without a flow accumulator. Replace 3 roller pump head with the 6 roller pump head to reduce pulsing. - Completed.
6. Design experiments/(2/26/16) - Jonathan. Design experiments testing for head loss and effluent turbidity based on coagulant dose. - Completed.
7. Design and build flocculator/(2/26/16) - Theresa. Design flocculator with G greater than 200 so that flocs are small. - Completed.
8. Refine PID control/(3/9/16) - Lucinda. Find correct P and I values for maintaining constant influent turbidity. - Completed.

9. Run experiments/(4/22/16) - Theresa. Test sand filter performance and collect data on head loss and effluent turbidity over time. - Completed.
10. Analyze data/(4/29/16)- Jonathan. Plot pC^* curves and head loss data as a function of run time and coagulant dosage. Assess effectiveness of PACl concentration. - Completed
11. Assess filter height and modify if necessary/(4/29/16) - Lucinda. See if sand is saturated with flocs or whether areas of sand are not being utilized. Reassess 20cm as optimal filter depth. - Completed
12. Create mathematical models/(5/11/16) - Theresa. The model should predict head loss as a function of coagulant dosage and the mass of solids accumulated. The model should predict pore storage volume as a function of coagulant dosage. Define and predict most relevant parameters. - Future Work

Report Proofreader: Theresa Chu