



AguaClara

Low Flow Stacked Rapid Sand Filter - 30cm team

**Sarah Sinclair, Chris Wen,
and Lishan Zhu**

Background



Joining Filter Column



Inlet and Outlet Piping



Couplings and Adapters



Entrance and Exit Tanks

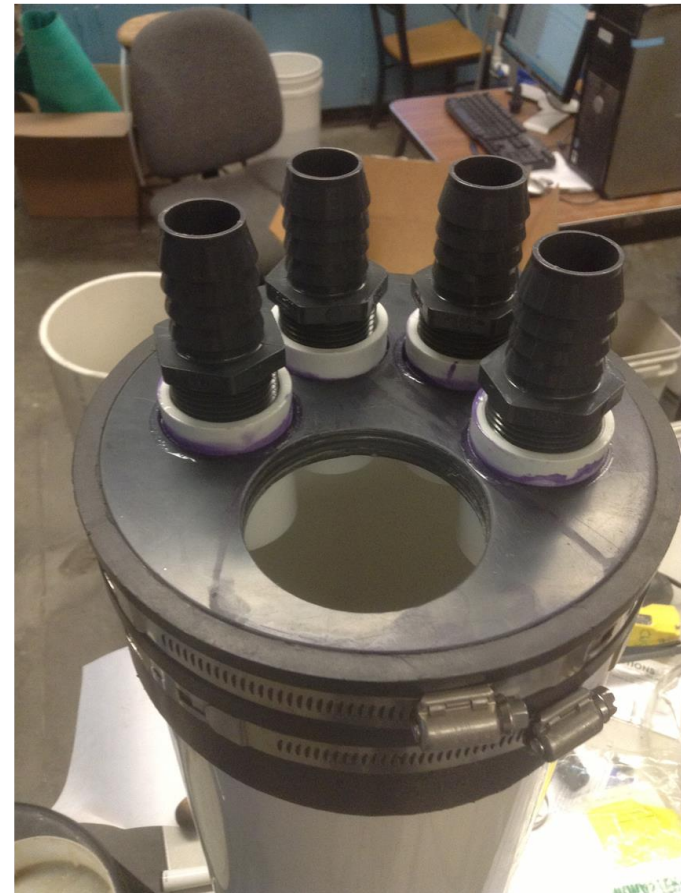

Spacers

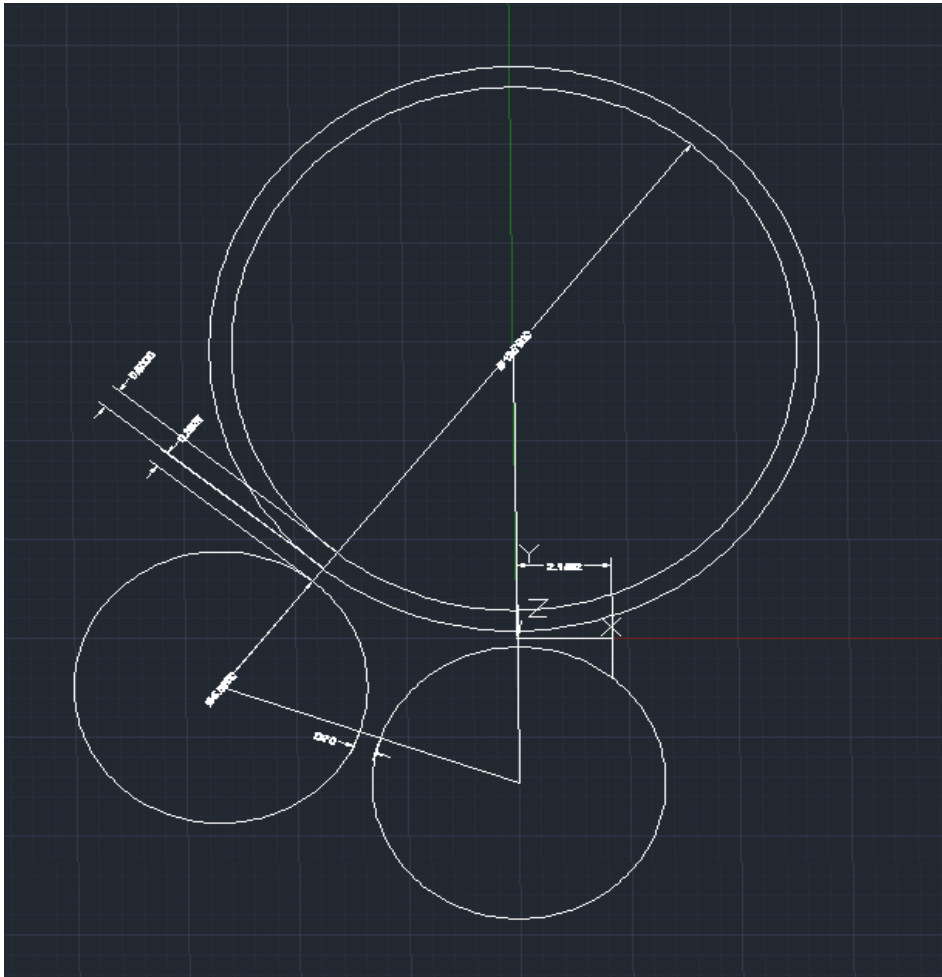

Attaching to Filter



Backwash Waste Pipe Design

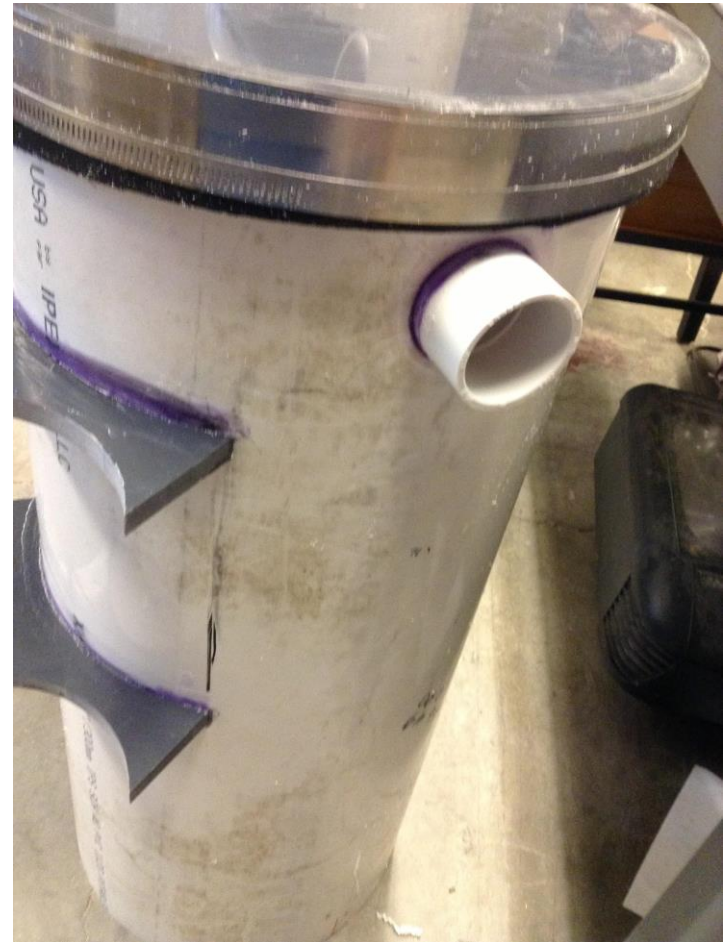
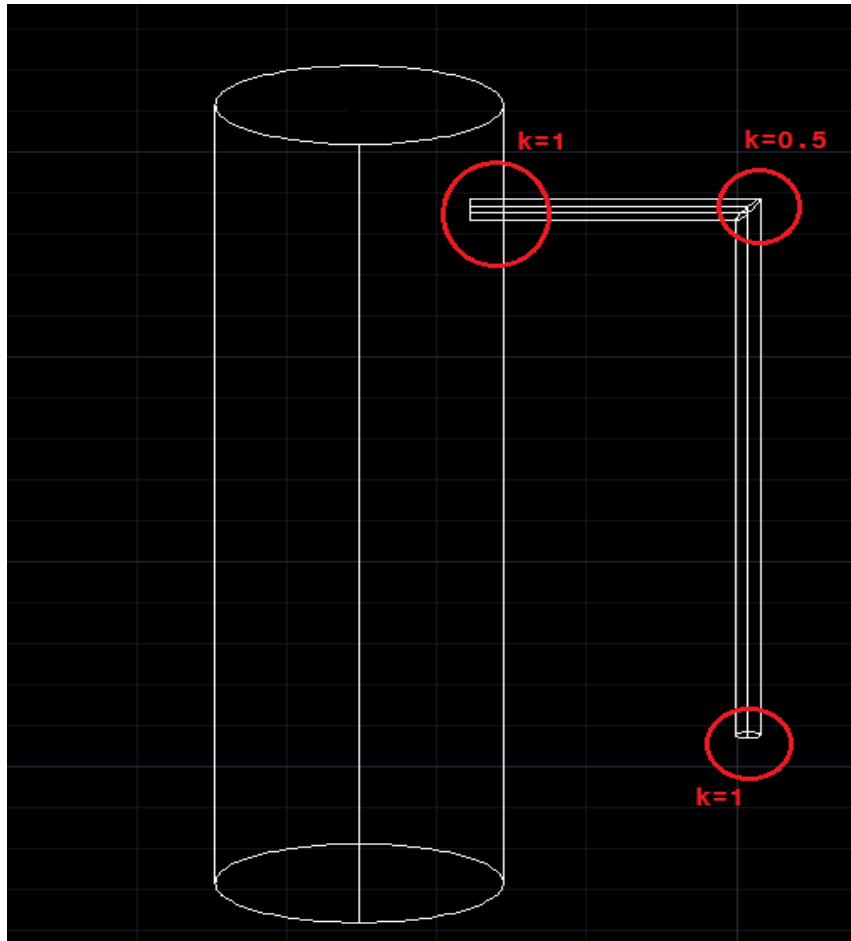

Future Work



Future Work

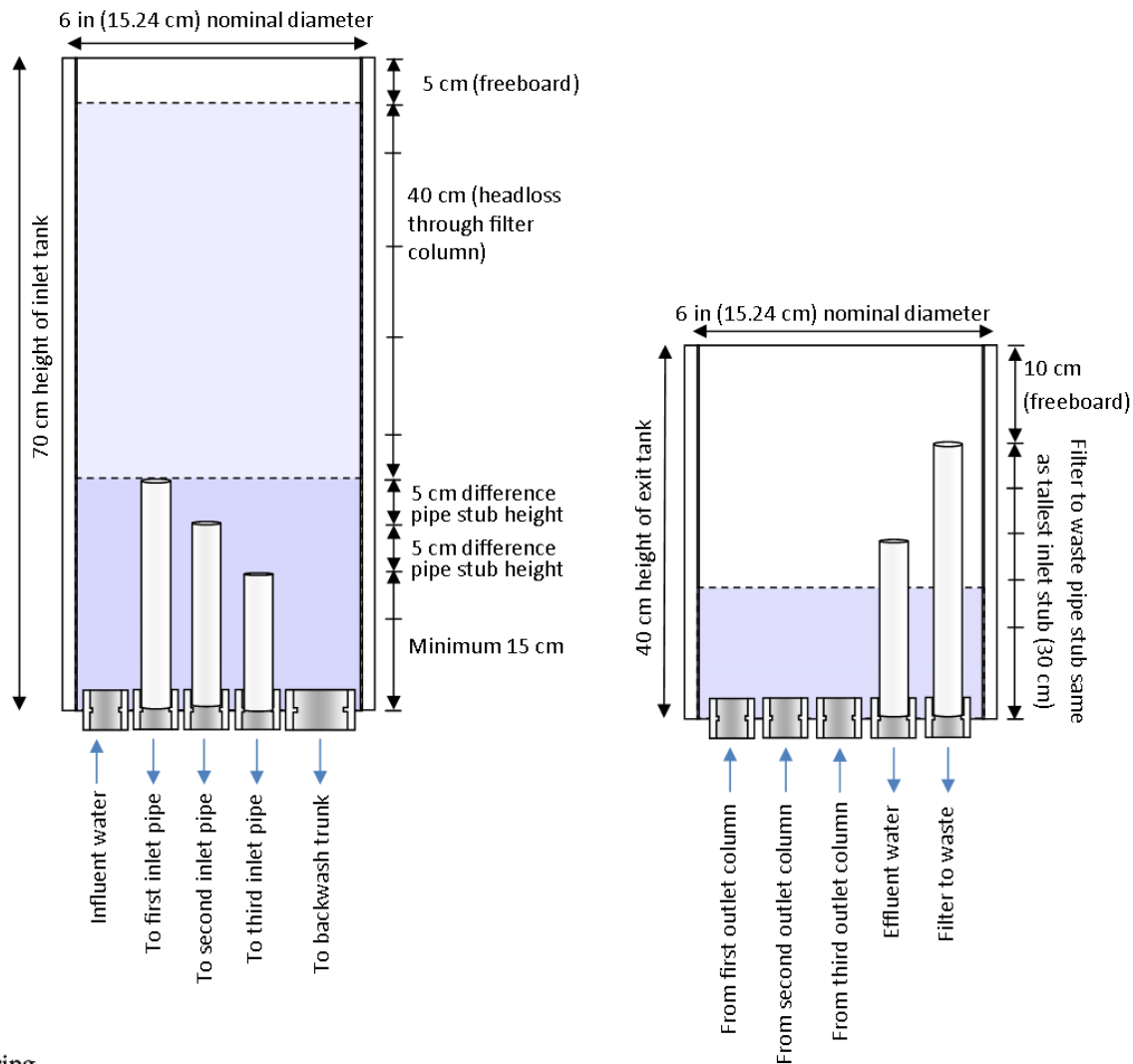

Future Work

