

Enclosed Stacked Rapid Sand Filtration (EStARS) Spring 2015

Sarah Bolander, Skyler Erickson, Liza Johnson, Subhani Katugampala, Lilly Mendoza

May 6, 2015

Abstract

The Spring 2015 EStARS team built upon the work of previous semesters to optimize the original filter design as well as to develop alternative strategies to sections of the filtering process. Over the course of the semester, the team altered the process for attaching the filter cap in order to prevent future cases of blow-off, adjusted the system for controlling water level height during backwash, and ran tests on filtration efficiency. While at the beginning of the spring semester the team's goals also included developing a method of testing and recognizing bed fluidization within the filter, looking into a method of running multiple filters in parallel, and setting parameters for backwash duration and frequency, the team changed directions and concerned itself with the implementation of a new filter injection system to combat the problems associated with using slotted pipes.

Table of Contents

[Abstract](#)

[Table of Contents](#)

[Task List](#)

[Task Map](#)

[Task Details](#)

[Introduction](#)

[Literature Review](#)

[Stacked Filters: A Novel Approach to Rapid Sand Filtration](#)

[EStARS Spring 2014 Report](#)

[EStARS Summer 2014 Report](#)

[EStARS Fall 2014 Report](#)

[StaRS Filtration and Extraction](#)

Methods

[Filter Setup](#)

[Filter Cap](#)

[Backwash](#)

[Measuring Filter Efficiency](#)

[Design of the New EStARS Inlet System](#)

[Fabrication of the New EStARS Inlet System](#)

[Removal of Old System and Installation of the New EStARS Inlet System](#)

Analysis

[Air Bubbles](#)

[Manometers](#)

[Reverse Flow](#)

Future Work

References

Introduction

Sand filtration is a very common drinking water treatment technology that is used in multiple ways and combinations. There are plants that use sand filtration as the last stage of drinking water treatment to remove low turbidities, and there are treatment options that consist solely of sand filters with different porosities in series to treat higher turbidities. AguaClara has developed a Stacked Rapid Sand Filter that is used as the last stage of treatment in a full scale AguaClara plant, as well as an Enclosed Stacked Rapid Sand Filter (EStARS) to stand alone and operate at a much lower flow rate. The advantage of the AguaClara Stacked Rapid Sand Filter is that it requires significantly less space than traditional sand bed filters do, and it can be backwashed without electricity by manipulating the flow rate to flow only through the bottom layer of sand. These key advantages make the Stacked Rapid Sand Filter cheaper to construct and operate, and easier to maintain in the field.

Formerly known as the Low Flow Stacked Rapid Sand Filter (LFSRSF) team, the EStARS team is continuing to work on developing a stacked rapid sand filter that treats water at low flow rates. These low-flow filters are useful in areas (such as the rural villages in India in which they are currently being implemented) where a full-sized AguaClara plant would not be economically or technically feasible for such a small flow rate. The EStARS filters being used in India are treating water drawn from wells at a design flow rate of 0.8 L/s each and are providing water to villages of around 600 people.

The many villages in India, as well as the various small communities throughout the world, would greatly benefit from the development of a low flow filter that could be implemented and constructed using accessible materials. For this reason, the EStARS team remains focused on designing a filter that is simply constructed and straightforward to operate. Furthermore, to account for fluctuations in community size, the filters will be designed so they can be easily added and run in parallel to an already existing set of functioning filters. There exists the potential for mass production of these filters, and especially in this case, the ease of production and the overall effectiveness of the EStARS filters must be made certain.

Literature Review

Stacked Filters: Novel Approach to Rapid Sand Filtration

This paper outlines the new concept of stacked rapid sand filtration. In comparison to the traditional slow sand filters, these rapid sand filters make use of the stackability of sand to condense the land area, whilst cleaning influent water to standards for drinking water asset by the EPA. In addition to lessening the overall surface area of sand filters, rapid sand filtration

eliminates the need for additional pumps in order to backwash the filters. Due to its novel approach in utilizing the same total flow rate for both filtration and backwashing, the backwash velocity will still be greater than the filtration velocity by a factor dependent on the number of layers of sand.

EStARS Spring 2014 Report

The Spring 2014 EStARS team fabricated and constructed a working filter. The filter bed was constructed using a system of slotted pipes and large PVC trunks, as well as pressure valves installed on the side of the filter. The team also set up a water recycling system in the event that the sinks cannot handle the volume of water during long trial runs. The design was created under consideration of the head loss and backwash velocity equations to ensure proper filtration and backwashing of filters.

EStARS Summer 2014 Report

The Summer 2014 AguaClara team was the first team to test out the newly fabricated EStARS filter set up by the Spring 2014 team. This team ran multiple tests to determine the efficiency of the filter as well as points for improvement in the setup design. Based on the experimental data from the summer semester, the team found that the observed head loss was less than the anticipated head loss, which led to the conclusion that head loss through the slotted pipes was not an issue, as was the initial concern. In addition, they altered the size of the slotted pipes to 0.3 mm in order to facilitate backwash at the design flow rate of 0.8 L/s.

EStARS Fall 2014 Report

The Fall 2014 AguaClara team realized that in order to improve the efficiency of the filters, the changes in head loss that occur during forward filtration and backwash must be monitored. By monitoring the changes in head, criteria for the initiation of backwash can be set and suggested to the operators of the filters.

StARS Filtration and Extraction

Both the open and the enclosed stacked rapid sand filters have been experiencing problems with clogging when implemented in the field. The slotted pipes being used for injection and extraction are thought to be the main weakness, so the Filter Injection and Extraction (FInE) subteam is designing alternatives to these slotted pipes.

The slotted pipes are intended to effectively allow the flow of water without movement of the sand by way of *size exclusion* – the size of the slots (0.2 mm in width) in the pipe determine what substances are allowed to pass through. The FInE team is proposing a new injection and extraction design that involves *gravity exclusion* – the geometries of injection and extraction methods will be such that there will be regions where only water is present and where sand cannot move up and out through either the inlets or the outlets.

The initial design of the injection method was a pipe with two vertically aligned wings that point downward from the pipe (as can be seen in Figure 1). The pipe tested by the FInE team has orifices opened every 10 cm, and these orifices are large enough to deliver the proper flow and to not get clogged by sand. The most recent design of filter injection is a simplified version of the aforementioned initial design - it now is only a pipe with orifices and does not include the wings. This injection method should work despite the lack of an obvious exclusion region because water should not be flowing up through the inlet branches, so the water in the pipes themselves act as the exclusion region. This means however, that unlike the slotted pipes, this injection system does not support reverse flow (which is used to purge the slotted pipes in the EStARS filters in India). This design is more preferred to slotted pipes as they are much easier to manufacture and eliminate the possibility of clogging the inlets.

Different constraints are presented by the different purposes of the injection and extraction method, so unlike the slotted pipes, the design of the injection points is different from the extraction points. For extraction, it must be considered that water is not continuously flowing out and thus the entrance of sand is a greater problem than for injection. To address this problem, the extraction design involves the use of wings. The initial design required two sets of wings (as can be seen in Figure 1), but the newer design only involves one set of wings that form a roof-like structure over the pipe. The wings are at an angle out away from the pipe, and this is to increase the area of the sand-water interface at the point of extraction in order to avoid fluidization and the lifting-up of the sand into the extraction pipes. The current design is being tested in the lab with a set of two holes every 10 cm, and they are located on either side of the pipe pointing out parallel to the floor (as opposed to pointing up or down). There are certain points of concern regarding the change of design. One such concern is the increase in area caused by the angling of the wings on the extraction manifold branches – the initiation of backwash may prove more difficult, and there exists a greater potential for dead zones and preferential flow than with the slotted pipes. The structural strength of the new designs must be tested as well, for especially in the open filter, large amounts of force can be felt by the tubes during the initiation of backwash.

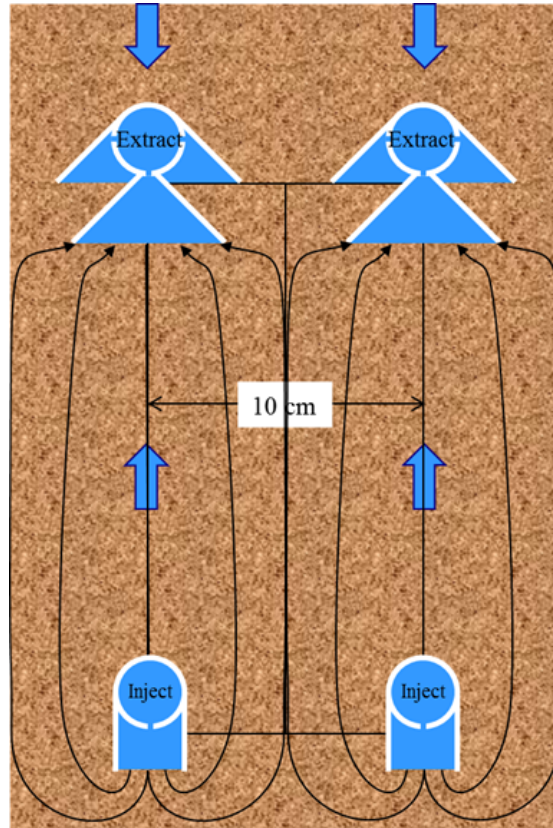

Figure 1: The initial proposed injection and extraction designs and flow through the filter - the model has since been simplified to make more efficient use of materials

The EStARS team began testing these new designs for injection and extraction in order to improve the filtration system and avoid further problems with clogging in the field. Currently, we have installed the injection design proposed by the FInE team in our filter body. This inlet system consists of a pipe with orifices aligned along the bottom of the pipe branch. As the semester concludes, we hope to have a functioning model using the injection system.

Methods

Filter Setup

The full setup of the EStARS is shown below in Figure 2 below. This image shows the current laboratory setup, including the entrance and exit tanks as well as the backwash pipe.

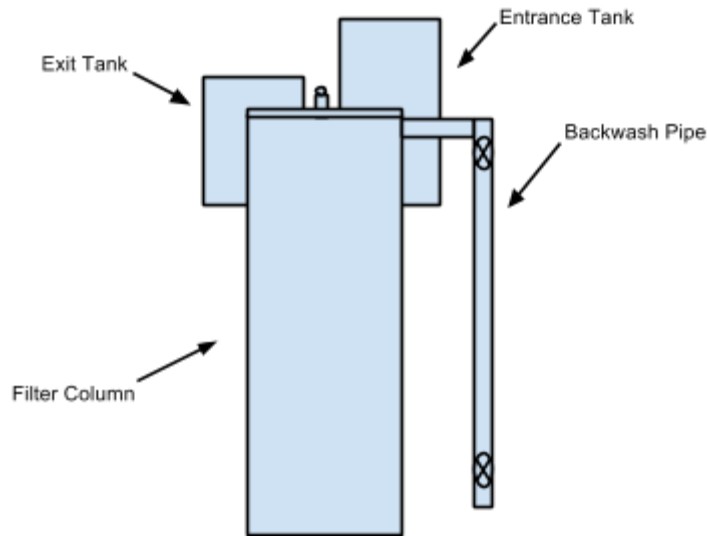

Figure 2: The EStARS filter setup

The filter column consists of six sections of sand, arbitrarily called layers. These layers are not actually separate classifications of sand, but rather, uniformly distributed sand of various pore sizes divided by the four inlet and three outlet tubes, as shown in Figure 3 below. During filtration mode, influent water feeds into the entrance tank. The water then flows into the filter column through the designated inlet pipes, where the water either flows upwards or downwards through a layer of sand to the nearest outlet pipe, which feeds into the exit tank and the effluent water leaves through the exit pipe and is distributed to the community's distribution tank.

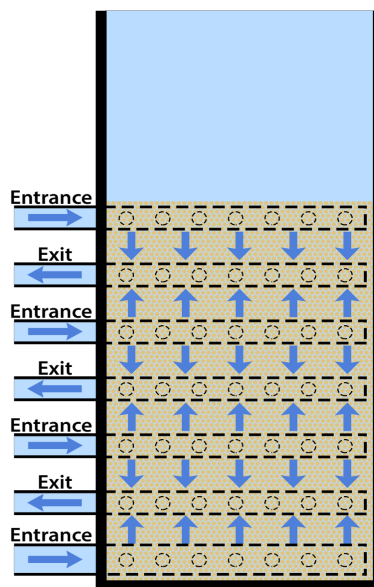

Figure 3: A zoomed in view of the filter bed during filtration mode

For backwash mode, the exit pipe (used to discharge water to the distribution tank) is blocked. This, in turn, causes the water entering the entrance tank to enter into the filter bed, thus filling the filter column completely with water. Once the column is entirely filled, the operator opens the siphon to initiate backwash which then releases the water from the filter bed into a backwash pool.

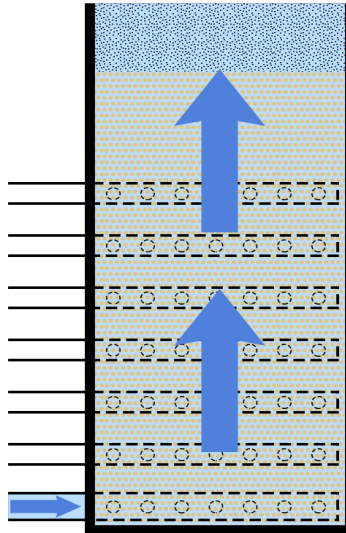

Figure 4: A zoomed in view of the filter bed during backwash mode

In order for backwash to be properly initiated, water must enter solely through the bottom of the filter column, as shown in Figure 4 above. The water passes through the layers of sand in one direction (from bottom to top), achieving the proper velocity needed to fluidize the sand. The fluidization of the sand bed enables the filtered material to be released and removed from the filter column and into the backwash pool. The head loss through the filter column must be precisely monitored to ensure that water only passes through the bottom-most inlet tube. Shown in Figure 5 below is the interior of the entrance tank with the four inlet pipes.



Figure 5: The four entrances to the tubes that enter the filter column (the pipe that corresponds to the bottom-most inlet tube is the pipe with the largest diameter)

Filter Cap

The filter column cap has popped off on several occasions (all during forward filtration) since the filter's initial construction in the lab. In order to design a reliable cap, various scenarios were tested to see the potential cases in which the cap would become dislodged. The cap did not maintain its integrity when the filter was run in forward filtration with all three exits from the filter column stopped using weirs in the exit tank that were higher than the height of the exit tank. This same scenario of blocking all three exits from the filter column was repeated three times. The first and second test resulted in the cap failing due to the PVC sheet circle coming completely dislodged from the rubber gasket, while the third test resulted in failure due to water leaking out the top where the PVC sheet perimeter meets the rubber. For the first two tests, the hose clamps had been tightened using a torque wrench set to 60 lb-inches, but for the third, the hose clamps had only been tightened using a screwdriver, which may have accounted for the water leakage.

The three filter cap tests mentioned above were all run using clean water from the tap with no addition of clay or coagulant. While a situation in which all exits are blocked using weirs during forward filtration is unlikely, the situation could be likened to the case in which all the slotted pipes for extraction from the filter column are near completely clogged during forward filtration. The system was run with the addition of clay and coagulant in order to analyze the changes in head loss throughout the process of forward filtration, backwash initiation, and backwash. During this monitoring, there were no signs of the cap blowing off, even with the addition of potentially clogging particles.

After the cap was purposefully dislodged for the third time, it was reattached using a torque wrench. Instead of lining the stainless steel shim stock underneath both hose clamps, the upper hose clamp is nestled into a fitted groove in the rubber fitting so the gap that was previously there (as the groove under the shim stock) is gone. The lower hose clamp still is attached on the outside of the shim stock as there is no second groove. A photograph of the current setup is provided as Figure 6 below, while the diagrams in Figure 7 show the difference between the old and the new assembly of the filter cap.

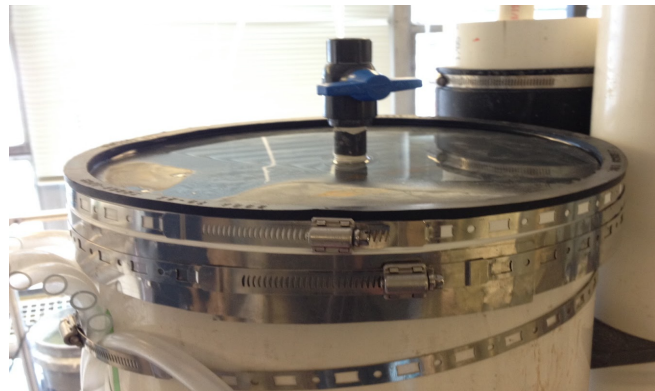

Figure 6: Current set-up of the filter column cap

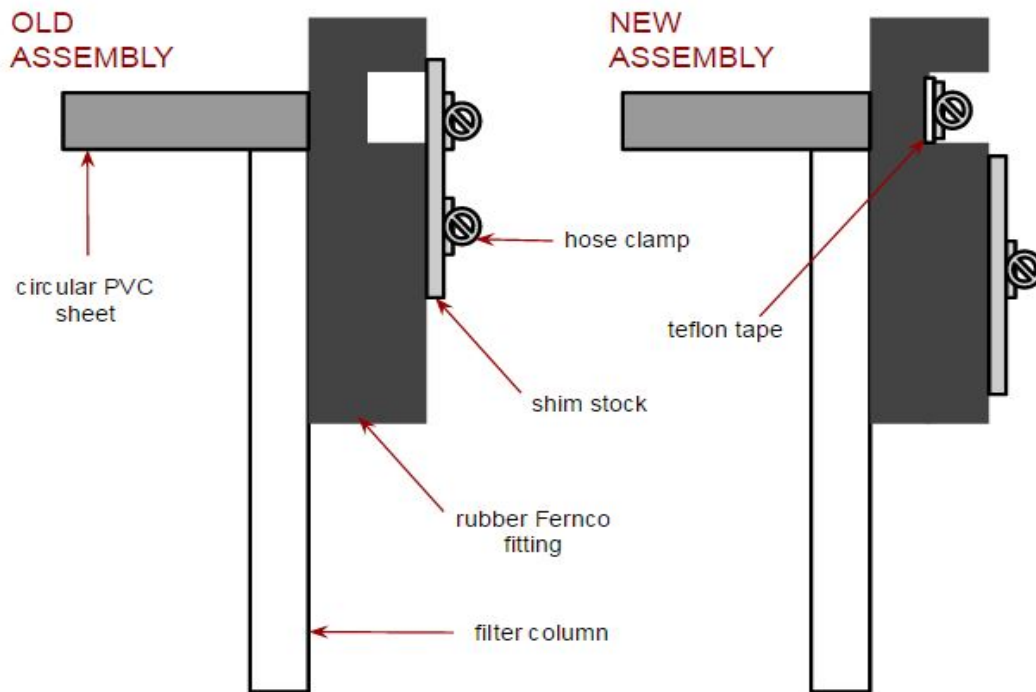

Figure 7: A comparison of the old assembly and the new assembly of the filter column cap

With this improved assembly, when the filter exits were stopped using the method mentioned above, the system overflowed from the entrance tank before there was any dislodging of the cap.

Backwash

With the current design of the entrance tank and siphon, as well as with the method by which backwash is initiated, large air bubbles become trapped in the lowermost inlet to the filter column through which all of the influent during backwash must flow. The original method for backwash is as follows:

1. Put a weir on the exit to the exit tank to begin raising the water level in the filter column
2. Open the valve on the top of the filter column (part of the cap) in order to allow all air in the column to escape
3. Close the valve on the top of the filter column once water begins to flow out of it
4. Immediately open the valve at the base of the siphon all the way

When the valve to the siphon was opened all at once, the water level in the entrance tank would drop rapidly to a point below the base of the entrance tank, allowing air to also enter and then get trapped in the lowermost inlet tube. The water level in the entrance would rise enough to completely cover the lowermost inlet tube even when backwashing with clean water after this initial drop, so step 4 is now taken more slowly so that the valve is eased open

and the water level in the entrance tank lowers at a slower rate (never dropping below the entrance tank base).

Even when the water level does not fall below the openings in the entrance tanks for the inlet tubes during backwash, the water that is coming into the entrance tank from the external pump is causing small air bubbles to enter the inlet tube. The water slightly fountains upon its vertical entrance into the tank and disrupts the water surface enough to result in the incorporation of air. To combat this problem, a cap will be placed over the pipe stub where the water is being pumped into the entrance tank in such a way that the entrance is not completely covered but the direction of the water is reversed to eliminate fountaining. The cap must allow for the two tubes (for coagulant and clay dosing) that are inserted into the tube bringing water into the entrance tank as well.

Measuring Filter Efficiency

Before taking apart the filter body to install the new inlet design, we ran a final filter efficiency test with the slotted pipes as our inlet system. To do this, we followed a procedure guideline on how to operate the filter and gather sufficient results. First, we run the filter in forward filtration with clean water. After a short time, we turn on the peristaltic pumps that control the addition of clay and the coagulant. We allow the filter to run until it reaches failure mode, which signals the start of backwash. We arbitrarily determined that the filter would be in failure once the effluent turbidity reading spiked, which means that the filter is not performing at its optimal capacity. After the effluent turbidimeter reads this value, we let headloss in the entrance tank drop and begin backwash. During both filtration and backwash, we monitor the headloss of the full filter by measuring the difference in water heights between the inlet and exit tanks.

Prior to this run, we modified our siphon setup to decrease the appearance of air bubbles during backwash. We did so by simply placing a bucket under the exit to the siphon in order to keep it fully submerged. Consequently, the addition of the bucket added height to our siphon, which meant that the water height in the entrance tank increased. So even though there were no more air bubbles, water was high enough to enter the other inlets, which isn't optimal when backwashing, since we want water to flow only from the bottommost inlet.

In the filter run documented in Table 1 below, we ran the filter in forward filtration until we ran out of coagulant. At this time, we also reached a convincing filter failure mode of ~40 NTU from our effluent turbidimeter. During the filter run, we decreased the coagulant dosage to prolong the run time. We recorded data during forward filtration, and once the coagulant supply was empty, we started to backwash. With the new siphon system, we were able to switch back and forth from filtration to backwash without the need of inserting a separate backwash weir into our exit pipe by using only the siphon valve. This is an improvement from the previous system as now the operator can easily switch from filtration to backwash by opening or closing a valve, leaving less chance for operator error.

Table 1: A table of the values recorded while running the filter

Trial Date	Average Influent Turbidity (NTU)	Average Effluent Turbidity (NTU)	Run Time (s)	Headloss Through Full Filter (Inlet tank to Exit Tank)	Coagulant Dose (mg/L)
4/23 /15	544	4.2	500	55	25
	550	4.3	885	50	12.5
	570	5.1	1170	46	6.25
	594	8.8	1470	45	6.25
	631	20	1810	43	6.25
	651	42	1980	41.5	6.25
	665	38	2130	41	6.25

Design of the New EStARS Inlet System

Design of the new inlet system began with determining the size and placement of orifices along the filter inlet manifold branches. For clarity, the different parts of the filter are labeled on Figure 9.

While the slotted branches of the inlet manifolds are being replaced by pipes with holes, the inlet manifold trunks are to remain the same as the previous design. The spacing between branches from center to center is 6.15 cm, as is noted in the Spring 2014 LFSRSF Report and can be seen in Figure 8.

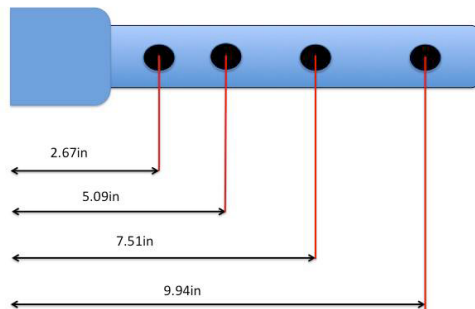

Figure 8: A diagram of the distances of the manifold branches from the filter column wall (from the Spring 2014 report)

The size of the orifices was determined by first setting the total head loss due to the orifices in the bottom inlet during backwash at 20 cm and basing further calculations off of this value. By

rearranging the equation for the flow through an orifice (Eq.1), the total orifice area needed for the backwash/bottom-most inlet was determined to be 6.52 cm².

$$A_{orificeSumBw} = \frac{Q_{total}}{\Pi_{VenaContracta} \sqrt{2gh}} \quad \text{Eq. 1}$$

Where

$$Q_{total} = 0.8 \text{ L/s}$$

$$\Pi_{VenaContracta} = 0.62$$

$$h = 20 \text{ cm}$$

This area was then considered to be the same as the sum of the areas of the orifices of the topmost inlet, because both the backwash/bottommost inlet and the topmost inlet serve only one layer of sand. The middle two inlets serve two layers of sand, so in order to keep the head loss equal among the four inlets during forward filtration, the sum of the orifice areas of each of the middle inlets must equal twice that of the total orifice area of the backwash inlet. The sum of the orifice areas of one middle inlet is thus 13.03cm².

The number of orifices per inlet was determined by first setting the distance between orifices along an inlet branch. This distance at first was set to equal half the length of the distance between two manifold branches, and the resulting spacing between orifices was about 3 cm. However, the diameter of the backwash inlet trunk is 5.08 cm, so the holes in the branches would provide less flow coverage to the area along the trunk. The spacing between orifices was then set to 5.58 cm by adding 0.25 cm of safety to the width of the backwash inlet's trunk diameter. The slight safety is a precaution against getting sand into the trunk line - although the length of safety is set to 0.25 cm, this is the length of pipe that appears outside of the trunk, while inside the trunk the branch pipe continues intact for about 1.8 cm. With a center to center orifice spacing of 5.58 cm, and given the lengths of each manifold branch given in the report by the Spring 2014 team, the number of orifices possible per branch was calculated by dividing the length each branch by the distance between orifices. From this calculation it was determined that the total number of orifices per inlet should be 6, with one hole on branches 1 and 2 and two holes on branches 3 and 4. While the upper three inlets have a 1" diameter trunk and the backwash inlet has a 2" diameter trunk, the placement of the orifices along the branches remains the same for all four inlets in order to maintain an even spacing across the trunk.

After determining the number of orifices needed per inlet and the necessary orifice area, the particular total orifice area needed at each inlet was divided by the number of inlets in order to determine what size the individual orifices should be. The orifices along and the bottommost and topmost inlets are smaller than those of middle two inlets.

The values at each step, as well as some of the relevant dimensions, are displayed in Tables 2 and 3.

Table 2: A table of the lengths of each branch (refer to Figure X for the branch labels) and the related the number of orifices

Branch	Branch Length (cm) (bottom/top three)	Number of Orifices
1	8.8 / 10.1	2
2	11.7 / 13.2	3
3	11.3 / 12.6	3
4	7.3 / 8.6	2

Table 3: A table of the values associated with each inlet's orifices

Inlet	Trunk Diameter (cm)	Total Orifice Area (cm ²)	Orifice Diameter (cm)
Top	2.5	6.5	0.6
Middle 1	2.5	13.0	0.9
Middle 2	2.5	13.0	0.9
Bottom/Backwash	5.1	6.5	0.6

By looking at the number of orifices per branch in respect to the length of the branch, it was evident that without slotted pipe, it is possible to reduce the length of pipe necessary for branches 1 and 4 because the single hole required of each of these branches does not necessitate the pipe extending further beyond the hole. This reduces the cost of filter fabrication as well as potentially allows for an easier fluidization of the sand bed (by being less obstructive).

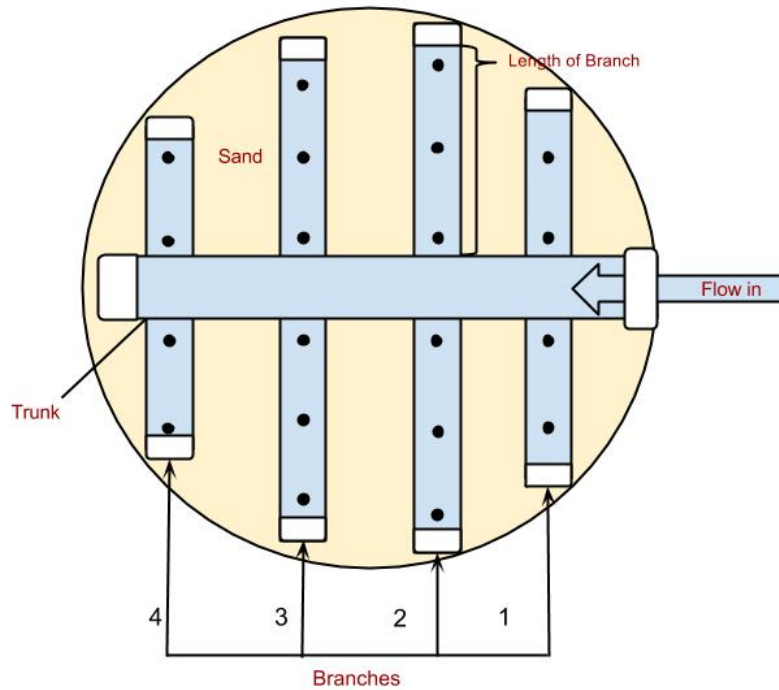

Figure 9: Cross-sectional view of the filter column and inlet manifold

Fabrication of the New EStARS Inlet System

Fabrication of the inlet manifolds involved cutting the branch manifolds to length (the branches were cut at twice their length, including the length needed for the diameter of the trunk and the space needed for caps), drilling orifices to serve the purpose of flow distribution instead of the slotted pipes, machining large holes at the center of each pipe so water can flow from the trunk into the branches (see Figure 10), sliding the branch pipes into the trunk pipes, attaching caps to the ends of the branches, and fitting the manifolds into the filter column.

The branch manifolds were cut to length out of 0.5" PVC pipe using the horizontal band saw.



Figure 10: A view down the trunk (with slotted pipe) that shows the hole machined so water can flow into the branch pipe from the trunk line

Removal of Old System and Installation of the New EStARS Inlet System

In the process of fabricating the new inlet design, the team decided to concurrently take apart the filter body and remove the slotted pipe inlet system to make efficient use of time. The first step to disassembling the filter was to remove the sand and water from the filter. After consulting the Summer 2014 EStARS team's second report, the best method for sand and water drainage was determined to be by running the filter in filtration mode with the exit shut and only two inlets open. This way, the only exit for the sand and water was the sand drain and the force was sufficient to force the sand out. This process lasted a couple of minutes with the entire filter body drained barring some sand below the sand drain. Once the filter was emptied, the next step was to detach the upper portion of the filter, including the entrance and exit tanks. To facilitate this process, all of the flexible tubing connecting the tanks to the filter body were detached. Next, one by one, the trunk manifolds were unscrewed, being careful not to reduce the integrity of the trunk itself since we were only replacing the slotted pipe branches. Then, for the trunks corresponding to the inlets, all of the slotted pipe branches were removed and once the new inlet system of pipes with orifices was fabricated, these pipes were inserted into the trunks. This process was followed for all four inlet trunks, and once completed, the filter body is slowly being reassembled. Currently, the team is working on reassembly of the filter. Before the addition of sand, we want to ensure that there are no failures of any connections and water flows through as it used to. We hope that we can get this accomplished prior to the end of the semester.

Analysis

Air Bubbles

Through numerous trials of running the filter and adjusting it, we figured out a way to eliminate the air bubbles during backwash. Our first step was to eliminate the fountaining effect of the water entering the entrance tank by cutting a hole in the inlet pipe for the water to come out of. The fountaining effect of water coming out of the top of the pipe would sometimes trap air. However, this does not fully solve the problem. In order for this new hole to eliminate the air bubbles, the water level needs to remain above the hole. During backwash, the goal is for the water to only enter through the bottom of the filter, so the water level must also be low enough to not enter the three other tubes which are at staggered heights. So, to completely eliminate the air bubbles, we found a way to keep the head loss in between the hole in the inlet pipe to the entrance tank and the second lowest tube so that the water is only flowing through the bottom tube. We did this by slowly opening the siphon and never opening it all the way. To do this was difficult because we were trying to maintain a very specific head loss height and if we opened it too far, air bubbles would arise. Now that we know a way to maintain the filter in backwash with no air bubbles, our goal is to find a more simple way to achieve that standard. This will involve adjusting the length of our siphon in order to manipulate the head loss in our entrance tank.

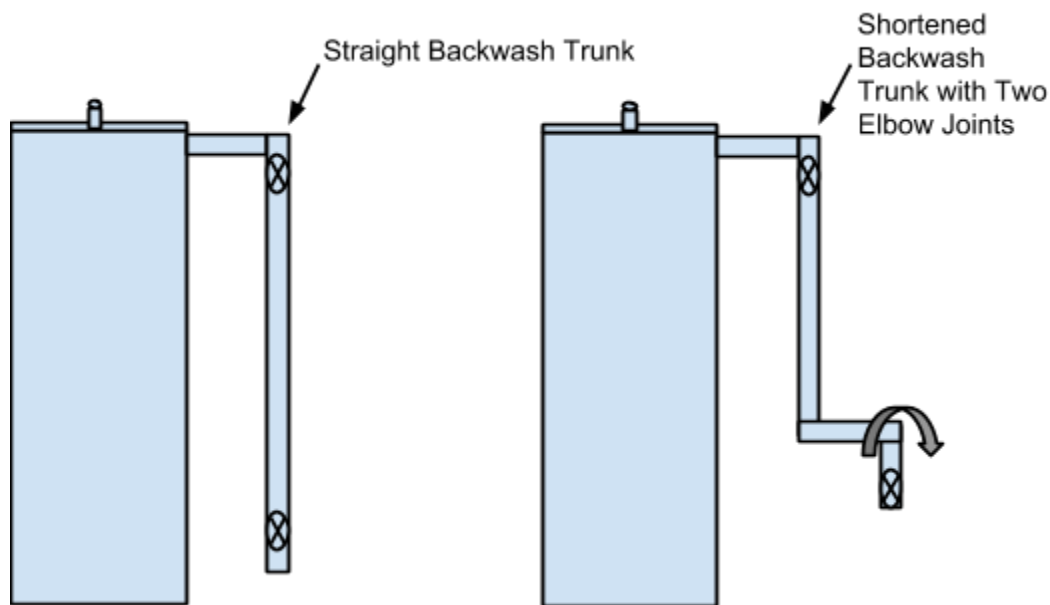

Figure 11: A comparison of the old assembly and the new assembly of the siphon system

In order to effectively resolve the problem of air bubbles, we are currently modifying the siphon system. Instead of having a siphon that is static and runs straight into our kiddie pool, we are making the system more dynamic with the use of elbow joints as shown above in Figure 11. The elbows will enable us to modify the height at which the backwash water is discharged. This is necessary as it builds up head in our entrance tank. This head ensures

that the water is at a high enough level where there is a sufficient amount of water (and no air) entering our backwash pipe and no water entering through the other inlet pipes. We have set up this system in our lab setup and have figured out the necessary height to adjust our siphon so we have proper backwash with no air bubbles. The team found that there is a very small height (~1") where the siphon is high enough to not suck air bubbles and also provides head loss in the entrance tank such that the water level is low enough to go only through the bottom inlet pipe. If we can achieve this height, we should not experience air bubbles, however it does not provide much room for error considering the inconsistencies we regularly see with backwashing the filter.

After further thought, the team decided to opt for a more simplistic design for the siphon. The presence of air bubbles indicates that at some point, our siphon is broken. The location of the siphon breaking was determined to be at the end of the siphon, where it is exposed to air. To fix this, either the double elbow system could be installed so there is no place for air to enter or a bucket of water could be placed under the exit of the siphon to submerge it, thus preventing water from entering up into the siphon. We opted for the latter as this would be the most simplest model to replicate in the field. The only problem of submerging the siphon exit is that by placing a bucket of water under the siphon, we are increasing the height of the siphon, and thus this increases the water level in the entrance tank. The increase in water height in the entrance tank causes water to enter not only the bottommost inlet, but the other inlets as well. This poses a problem, as backwash implies that water must only enter through the bottommost inlet in order to fully fluidize the sand bed. One way to fix this is by raising the inlet weirs in the entrance tank.

Manometers

The whole purpose of getting water to flow without air bubbles during backwash was so that we could accurately observe our manometers to characterize backwash efficiency across the filter bed. Our manometers are set up so that they measure the head 5 cm above and 5 cm below each inlet and outlet. Thus we have 12 manometers, and we can easily open these during backwash through a valve located on the side of the filter.

After finally manipulating the head in our entrance tank so that we have no air bubbles, and all the water is flowing through our bottom layer of sand, we observed a difference of ~5cm between each manometer moving from the bottom of the filter to the top of the filter as Figure 12 below shows. Our manometer corresponding to the bottom inlet had the highest head, then each manometer above it had successively ~5 cm less head. The even spacing between each manometer from bottom to top suggest that the sand bed was close to evenly fluidized.

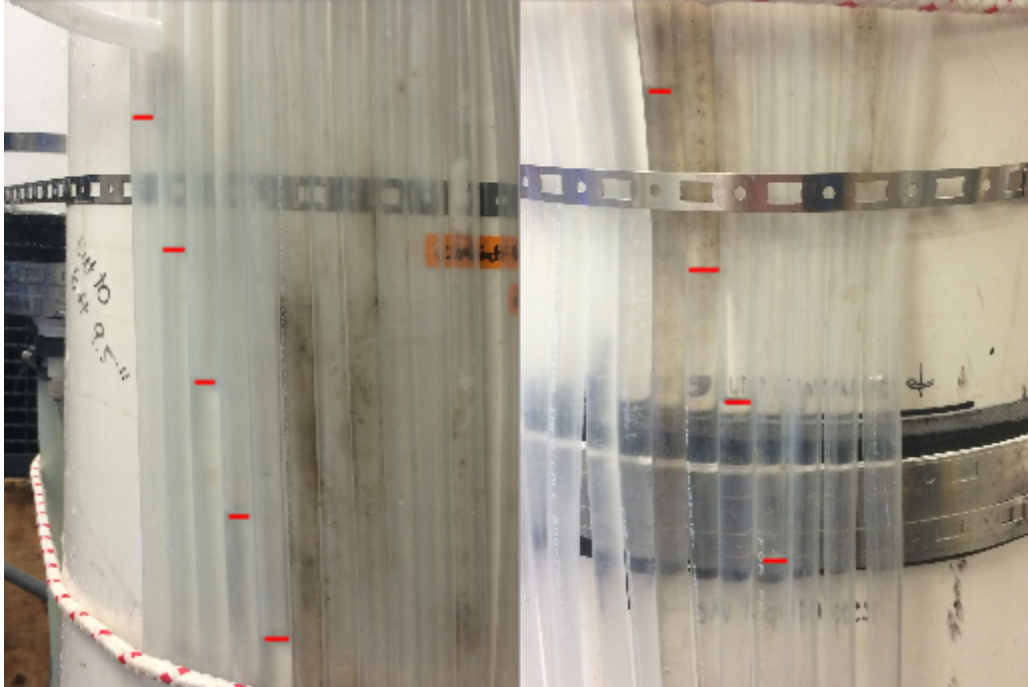

Figure 12: Manometer results showing ~5cm spacing between each manometer

One of our initial concerns was that the filter may not be fluidizing evenly and that there may be pockets of the sand bed that do not get fluidized at all. Our manometer results suggest that the filter is fluidizing at a fairly consistent level throughout the sand bed, and these results are further supported by our ability to run the filter for a consistent amount of time with similar conditions following a backwash. Given that the manometers are spaced 10 cm apart, our results showing a difference of ~5cm in head suggest that we may be getting up to 50% bed fluidization within the filter. This is far above the 30% fluidization we aim for, and it is worth noting that we do not observe any sand coming out of the siphon either.

Reverse Flow

Before the installation of the new inlet system, the team must consider all possibilities of reverse flow in the filter. Reverse flow is when water travels backwards through the filter. This would be something to be mindful about in terms of our revised set up as there is the potential for sand to enter through the orifices. We have examined our current set up and determined that there is at least one instance of flow reversal.

When the filter is shut off immediately after backwash, we achieve notable flow reversal. Since the water level is so high in the pipe, it would cause the water to flow back down through the filter and into the exit tank, ultimately flowing down through the pipe attached to the pump and back into the bucket. This is the one identified instance of flow reversal as we can cause clogging in the entrance pipes and therefore ruin the effectiveness of our filter.

We may also receive some flow reversal during backwash, but we haven't directly observed this instance.

The solution came in the form of allowing the filter to transition back into filtration before shutting off the filter. Instead of disconnecting the pump right after backwash, we first removed the pipe blocking the exit tank. Then we closed the siphon and allowed the filter to run in forward filtration. By running forward filtration for a few minutes, we allowed the water level in the filter to return its usual level. This prevents the need for a backflow into the entrance tank because the filter is at a steady state.

Running the Filter with the new inlet pipes

At the very end of the semester, the team was able to run the sand filter with the new inlet orifices. The team was able to cycle back and forth between backwash and forward filtration with one valve that started the backwash siphon and then turned it off. We did this numerous times and saw sand for only a brief moment in the very top inlet. After forcing the sand out of the top inlet by lifting the U-flexible tubing above the inlet so the sand would drain out, we were able to cycle back and forth about 10 times very rapidly without seeing any signs of sand in our inlet tubing. This suggests that the system works efficiently at keeping sand out of the inlets with just the orifices for inlet pipes, and no slotted pipes for sand exclusion.

Furthermore, if a future team sees a problem with sand entering the inlet tubes, we have already ordered valves that would be easy to install at the inlets in order to completely stop reverse flow during backwash.

During backwash, we were able to get nearly all the water into our bottom inlet, with just a tiny bit trickling into the second lowest inlet. This is an easy fix by manipulating the siphon release height so that the water in the entrance tank is just high enough that it flows into the bottom inlet without drawing air bubbles, and just low enough so that it is not going into any other inlets. It is also worth mentioning that the system has a significant leak around the seal at the second inlet orifice that future teams should look into.

Future Work

Next semester's team should come up with a quick way to fabricate field manometers that can be used the same way our lab scale manometers do to assess backwash efficiency. Ideally next to these manometers could be an easy rubric that makes it easy for the operators to list a backwash bed expansion percentage. Alterations in design such as adding valves to the inlets to guarantee no reverse flow should be considered if the team sees sand in the inlet tubing in the future.

The new inlet system should now be run with clay and coagulant to further confirm that the system continues to operate well with the new inlets. Things to look into should include how well the filter performs at removing turbidity, the headloss running through the filter during both filtration and backwash as compared to headloss data with slotted pipes, and as always whether or not there is sand getting pushed into the inlet tubing/manifolds. The team should

come up with a good method for flushing sand from inlet tubing should this problem arise, and the team should well document any new operating procedure that must be met due to the new inlet pipes.

A new outlet design should be considered as well, and the differences in inlet and outlet geometries will require new types of tests to determine whether the wings on the outlets are still allowing the sand bed to sufficiently fluidize and whether the wings will stay properly attached to the branch pipes even with the strong upward forces applied to them at the initiation of backwash.

References

[Use Citation Machine APA Format](#)

Experimental Thermal and Fluid Science. (2006). *Science Direct*, 30(4), 329-336. Retrieved September 30, 2014, from

<http://www.sciencedirect.com/science/article/pii/S0894177705000993>

Journal of Environmental Engineering - 138(10):999 - Full Text HTML (ASCE). Web. 6 Mar.

2015. <[http://ascelibrary.org/doi/full/10.1061/\(ASCE\)EE.1943-7870.0000562](http://ascelibrary.org/doi/full/10.1061/(ASCE)EE.1943-7870.0000562)>.

Weber-Shirk, M. (2014, September 14). Flow Control and Measurement. Retrieved

September 30, 2014, from <https://confluence.cornell.edu/display/cee4540/Syllabus>