



OWNER'S MANUAL

MicroTOL Series Turbidimeter

Catalog No. 24034 (3/07)
Rev. 3.9

HF scientific, inc.
3170 Metro Parkway
Ft. Myers, FL 33916
Phone: 239-337-2116
Fax: 239-332-7643
E-Mail: info@hfscientific.com
Website: www.hfscientific.com

DECLARATION OF CONFORMITY

Application of Council Directive
Standards to Which Conformity is Declared:

Product Safety - Tested and passed CE EN61010-1: 1990 + A1: 1992 (73/32 EEC)
- Tested and passed ETL (tested to UL 61010B-1), 1st Edition, Dated
January 24, 2003
- Tested and passed ETLc (tested to CSA C22.2#1010.1-92)

Immunity – Tested and passed EN61326: 1997+A1: 1998
Including:
IEC61000-4-2
IEC 61000-4-3
IEC 61000-4-4
IEC 61000-4-5
IEC 61000-4-6
IEC 61000-4-8
IEC 61000-4-11

Emissions - Tested and passed EN61326: 1997+A1: 1998
Including:
CISPR 11 Radiated Emissions Class B
CISPR 11 Conducted Emissions Class B
EN 61000-3-2
EN 61000-3-3

Manufacturer's Name: HF scientific, inc.

Manufacturer's Address: 3170 Metro Parkway, Fort Myers, Florida 33916-7597

Importer's Name:

Importer's Address:

Type of Equipment: Process Turbidimeter

Model No: Micro TOL

I, the undersigned, hereby declare that the equipment specified above conforms to the
above Directive and Standard

Place: Fort Myers, Florida USA

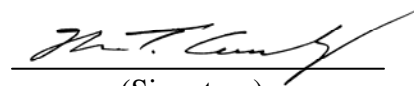
(Signature)

Rowan T. Connelly, General Manager

Table of Contents

Section	Page
Specifications	1
1.0 Overview.....	2
1.1 The Micro TOL Series	2
1.2 Unpacking and Inspection of the Instrument and Accessories	3
1.3 The Display	3
1.4 The Touch Pad	4
1.5 Vapor Purge	4
2.0 Safety	4
3.0 Installation and Commissioning	5
3.1 Mounting and Site Selection.....	5
3.2 Plumbing	6
3.2.1 Drain Vent.....	7
3.2.2 Wetted Materials.....	7
3.3 Electrical Connections	7
3.3.1 Power	8
3.3.2 RS-485	8
3.3.3 Relays.....	8
3.3.4 4-20 mA	8
4.0 Operation	9
4.1 Routine Measurement	9
4.2 Security Access Feature.....	9
5.0 Instrument Calibration	11
5.1 Calibration Standards	11
5.2 Calibration Procedures	12
5.3 Calibration Error	13
6.0 Instrument Offset	14
6.1 Indexing Calibration Cuvettes	15
6.2 Restoring Factory Settings.....	15
7.0 Instrument Configuration (CONFIG mode)	16
7.1 Selecting the Output (O/P)	16
7.2 Setting the 4-20 mA	16
7.3 Configuring the RS-485 Port	17
7.4 Configuring the Alarms	18
7.4.1 Alarm 1	18
7.4.2 Alarm 2	19
7.5 Offset Calibration.....	19

Table of Contents (continued)

Section	Page
7.6	Enabling the Security Access.....20
7.7	Extended Settings.....20
7.8	Speed of Response20
7.9	Displayed Resolution21
7.10	LCD Backlight Brightness.....21
7.11	Setting the Units.....22
7.12	Ultrasonic Cleaning22
7.13	RS- 485 Parameters.....22
7.14	Desiccant Alarm.....23
7.15	Saving Configuration Settings23
8.0	Additional Features and Options24
8.1	Backlit LCD.....24
8.2	Ultrasonic Cleaning24
8.3	RS-485 Output25
8.3.1	HF Online.....25
8.3.2	Simple Communication25
8.3.3	Modbus Communication.....26
8.4	Flow Alarm26
8.5	Flow Controller.....26
8.6	Remote Panel Meter.....26
9.0	Troubleshooting & Maintenance27
9.1	Micro TOL Fault Detection27
9.2	System Fail Message27
9.3	Diagnostic Chart28
9.4	Technical and Customer Assistance28
10.0	Routine Maintenance29
10.1	Cleaning the Flow Through Cuvette29
10.2	Replacing or Installing the Desiccant Pouch29
10.3	Replacing the Source Lamp29
11.0	Accessories and Replacement Parts List30
12.0	Warranty31

Specifications

Measurement Range	0 – 1000.0 NTU 0 – 100 NTU (Model 20055 & 20056)
Accuracy	±2% of reading or ±0.02 NTU below 40 NTU whichever is greater ±5% of reading above 40 NTU
Resolution	0.0001 NTU (below 10 NTU)
Response Time	Adjustable
Display	Multi-Line Liquid Crystal Backlit Display
Alarms	Two Programmable, 120-240VAC 2A Form C Relay
Analog Output	Powered 4-20 mA, 600 Ω drive
Communications Port	Bi-directional RS-485, Modbus
Maximum Water Pressure	Integral pressure regulator rated 1380kPa (200 PSI.) Also refer to Flow Rate
Flow Rate	100 ml/min. – 1 liter/min. (.026-.26 Gal/min)
Operating Temperature	1°C – 50°C (34°F – 122°F)
Wetted Materials	Nylon, Borosilicate Glass, Silicon, Polypropylene, Stainless Steel
Sample Temperature Range	1°C – 50°C (34°F – 122°F)
Power Supply	100 – 240 VAC, 47 – 63 Hz, 80VA
Insulation Rating	Double Insulated, Pollution Degree 2, Overvoltage Category II
Environmental Conditions	Not recommended for outdoor use. Altitude up to 2000 meters Up to 95 % RH (non-condensing)
Enclosure Rating	Designed to meet IP 66 /NEMA 4X
Regulatory Compliance And Certifications	White Light Version compliant to U.S. EPA 180.1 Infrared Version compliant to ISO 7027 CE Approved, ETL listed to UL 61010B-1 & ETL Certified to CSA 22.2 No. 1010-1-92
Shipping Weight	2.5 kg (5.5 lbs.)
Warranty	1 Year from date of shipment

1.0 Overview

The MICRO TOL process turbidimeter allows for the measurement of the turbidity of process water on-line. The White Light MICRO TOL has been designed to meet the design criteria specified by the US EPA 180.1 on turbidity measurement. The infrared MICRO TOL was designed to meet the design criteria specified in ISO 7027 and DIN 27027 for the measurement of the turbidity of a sample. Both models have long life lamps.

Some models have ultrasonic cleaning. Refer to section 8.2 for more information.

A pressure regulator on the incoming line is a standard on all Micro TOL instruments and will reduce pressures up to 1380kPa (200 PSI) down to (104kPa) 15 PSI.

1.1 The Micro TOL Series

The Micro TOL series instruments have a wide variety of options available. Refer to the table below to determine which factory installed options are available.

Catalog No.	Description	RS-485	Modbus	Backlight	Ultrasonic Cleaning	Range NTU	Flow Alarm
20053	Micro TOL2 WL	Standard	Standard	Standard	N/A	0-1000	Option
20054	Micro TOL2 IR	Standard	Standard	Standard	N/A	0-1000	Option
20055	Micro TOL3 WL	Standard	Standard	Standard	Standard	0-100	Option
20056	Micro TOL3 IR	Standard	Standard	Standard	Standard	0-100	Option
20063	Micro TOL4 WL	Standard	Standard	Standard	Standard	0-1000	Option
20064	Micro TOL4 IR	Standard	Standard	Standard	Standard	0-1000	Option

1.2 Unpacking and Inspection of the Instrument and Accessories

The table below indicates the items in the turbidimeter shipment.

Item	Quantity
MICRO TOL Turbidimeter c/w Field Terminal Box & Flow Through Assembly	1
Instruction Manual	1
Desiccant Pack	1
Cuvette (Single Pack)	1
Tubing Kit: 1-shutoff clamp 1-backpressure valve 2-connecting tubing with fittings for flow through assembly 1-drain vent screw (used in pressurized systems)	1

Remove the instrument from the packing carton. Carefully inspect all items to ensure that no visible damage has occurred during shipment. If the items received do not match the order, please immediately contact the local distributor or the HF scientific, inc. Customer Service department.

Note: The spare cuvette part# 50033 is not included for models 20055, 20056 20063 & 20064. In these models a special ultrasonic cuvette is provided. This cuvette must be installed prior to operating the instrument.

1.3 The Display

Figure 1 illustrates all the items that can appear on the display. The upper row of the display (1) is used for reporting the turbidity levels and to provide user guidance in the customer setting routine. The lower row of the display (2) is used to communicate error messages and provide user guidance. The display has two icons (3) that are used to indicate the use of access code and offset mode. In addition, mode arrows (4) are used to indicate the current instrument operating mode; AUTO (normal operation), CAL (calibration) and CONFIG (configuration).

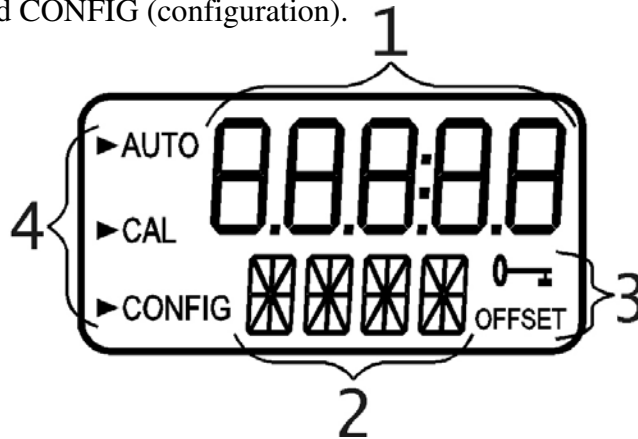

Figure 1 – Display used in the instrument.
All items used on the display are shown in this figure

1.4 The Touch Pad

Figure 2 illustrates the touch pad. The touch pad has four buttons: **MODE/EXIT**, ↵, ▲, and ▼. The **MODE/EXIT** button is used to cycle between the three operational modes of the instrument: **CAL**, **CONFIG**, and **AUTO** (Measurement) mode. The ↵ button enters the option (or mode that is highlighted or chosen. The ▲ and ▼ buttons are used to change settings.

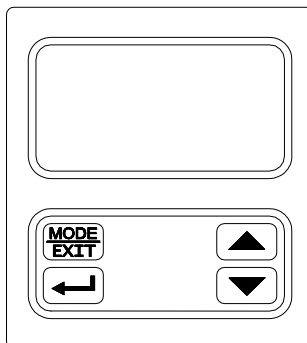

Figure 2: Touch Pad

1.5 Vapor Purge

The Micro TOL is equipped with a continuous vapor purge system. A replaceable desiccant pouch in the lower portion of the instrument dries the air. System heat is used to warm the air. A fan inside the instrument continuously circulates heated dry air around the optical well and the flow through cuvette. This feature eliminates the need for a dry purge line.

The Micro TOL monitors the replaceable desiccant pouch condition continuously. The LCD display will show **DESC** on the lower line in the event that the desiccant pouch needs replacement. Replacement desiccant pouches are available from HF scientific, inc. or the local representative (Part # 21555R). Refer to section [10.2 Replacing or installing the Desiccant Pouch](#).

The desiccant can activate an alarm to notify the operator of a saturated desiccant. See section [7.14 Desiccant Alarm](#).

2.0 Safety

This manual contains basic instructions that must be followed during the commissioning, operation, care and maintenance of the instrument. The safety protection provided by this equipment may be impaired if it is commissioned and/or used in a manner not described in this manual. Consequently, all responsible personnel must read this manual prior to working with this instrument.

In certain instances **Notes**, or helpful hints, have been highlighted to give further clarification to the instructions. Refer to the *Table of Contents* to easily find specific topics and to learn about unfamiliar terms.

3.0 Installation and Commissioning

Prior to use for the first time, the supplied desiccant pouch will need to be installed. Refer to section [10.2 Replacing or Installing the Desiccant Pouch](#).

3.1 Mounting & Site Selection

The instrument is designed for wall mounting. If wall mounting is not practical, the instrument can be mounted on any suitable level surface. For ease of service there should be about 20 cm (8") free area above the instrument; this will ensure enough room for calibration and cuvette maintenance. Choose a location that is easily accessible for operation and service and ensure that the front display rests at eye level. The overall mounting dimensions of the instrument are shown in Figure 3. The recommended mounting screws are M6 (1/4") for the instrument enclosure and M4 (#8) for the field terminal box. The Micro TOL is designed to have the field terminal box cradled under the sensor portion of the instrument. It is recommended that the field terminal box be mounted first, and then the rest of the instrument be mounted on top. The template on the last page of this manual may be used to establish mounting hole locations.

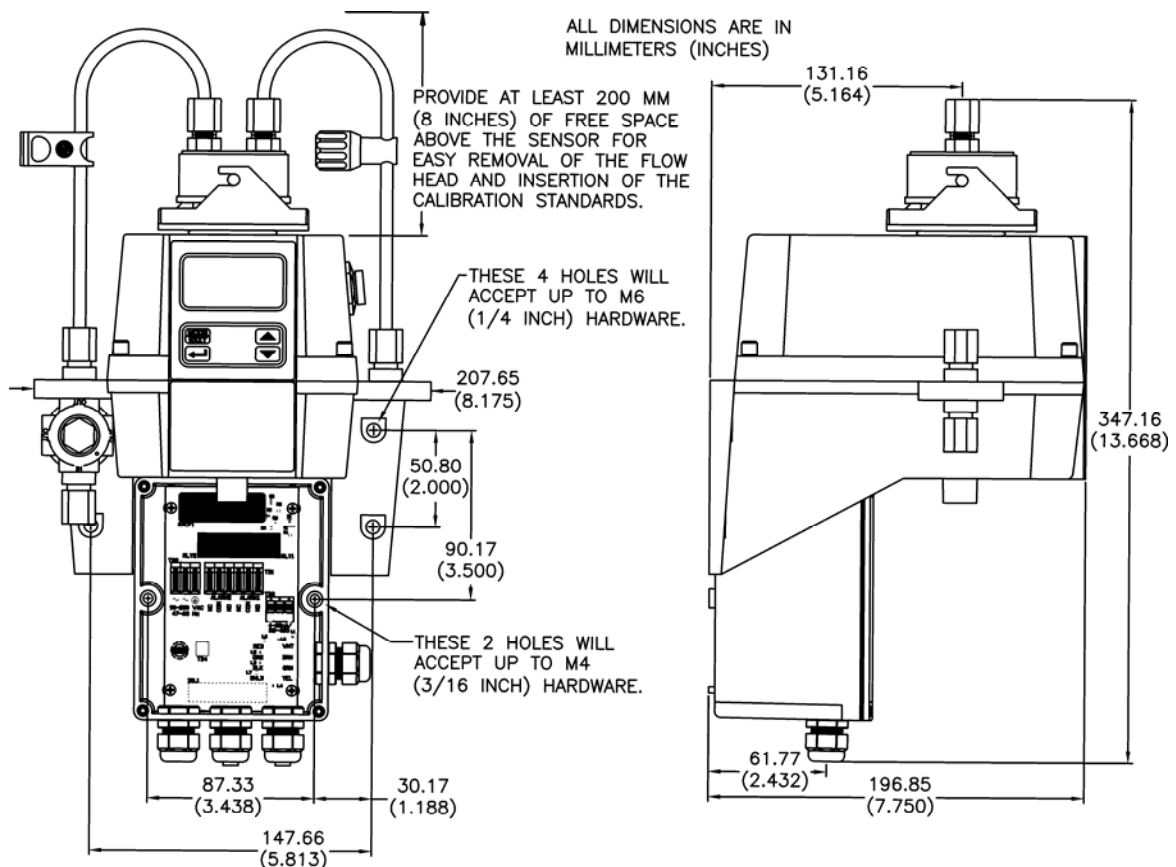

Figure 3: Overall Mounting Dimensions of the Instrument

It is critical that the instrument be mounted as close as possible to the sampling point to ensure a quick response time (within 2-3 meters (6-10 ft) of the sampling point).

3.2 Plumbing

The recommended plumbing for the instrument is shown in Figure 4. The instrument is designed to require very little head pressure to operate; around 6.9kPa (1 PSI). The flow through cuvette is rated for a flow of 100ml/min. – 1 liter/min. (0.026-0.26Gal/min). The integral pressure regulator is rated for a maximum pressure of 1380 kPa (200 PSI.). The maximum allowable fluid temperature is 50°C (122°F).

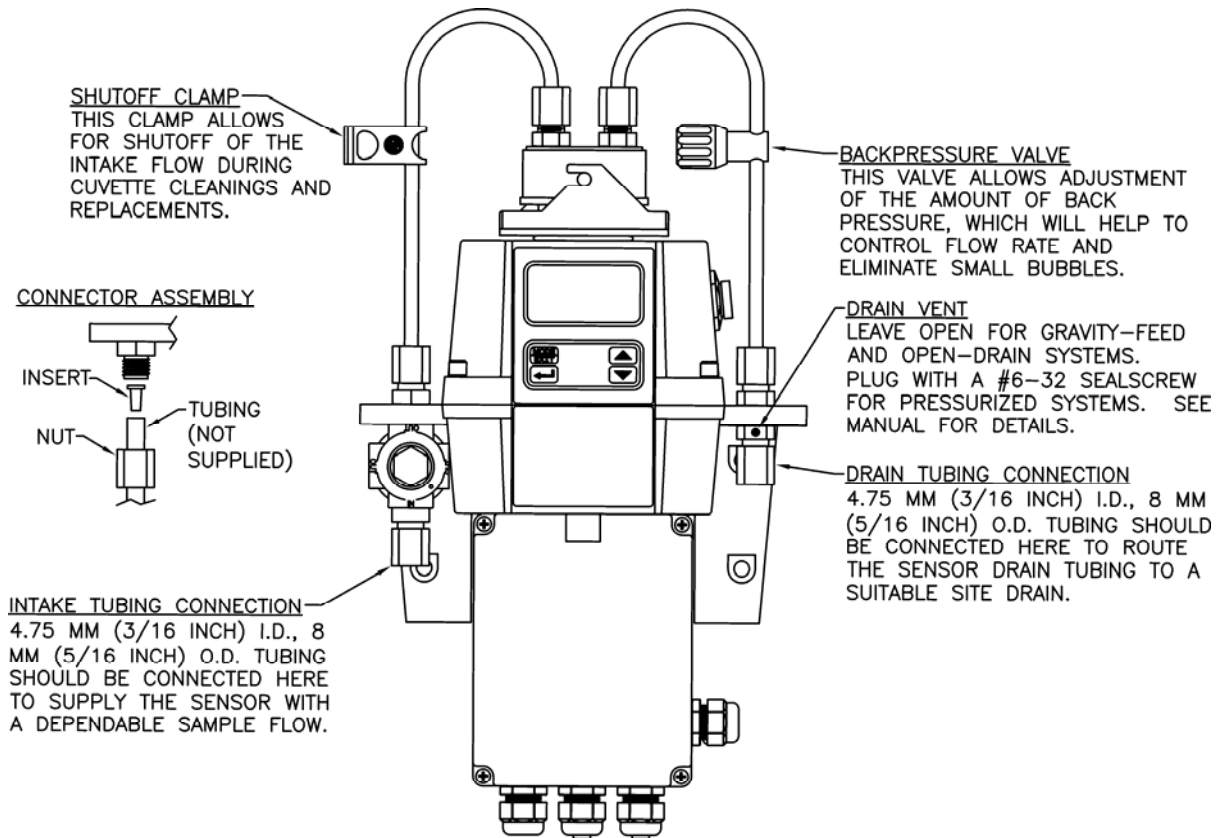

Figure 4: Recommended Plumbing for the Instrument

The instrument is equipped to be plumbed using 4.75 mm (3/16") ID, 8 mm (5/16") OD flexible tubing. Opaque tubing should be used if the tubing will be exposed to sunlight, to prevent algae growth.

In figure 4, there are two flow devices shown. The one on the input side is a shutoff clamp used during cuvette maintenance. The other device is a backpressure valve. Backpressure may be required to prevent air from coming out of solution, which may be observed as tiny air bubbles.

3.2.1 Drain Vent: The Micro TOL has been fitted with a drain vent in the “OUT” bulkhead fitting. This fitting allows for atmospheric equalization, thus helping to alleviate bubble formation in the cuvette. Refer to Figure 4.

Upon initial flow minor leakage may occur through the drain vent. This will subside once normal flow is established.

For some high pressure systems, where the vent hole continuously leaks, a 6:32 seal screw is provided which should be inserted into the vent hole and tightened.

The sensor drain tubing should be routed to a suitable drain. It is not recommended to reintroduce the drain sample to the process stream.

3.2.2 Wetted Materials: HF scientific inc. accepts no responsibility for damage caused by the introduction of vapors, fluids or other materials into the instrument process stream which is not compatible with the instrument’s wetted materials. A list of the wetted materials can be found in the specifications on page 1 of this manual.

3.3 Electrical Connections

All of the electrical connections to the instrument are made through the field terminal box, which should be located directly under the sensor portion of the instrument. The connections are labeled within the terminal box and are self-descriptive (see Figure 5). Please follow all local and government recommendations and methods for installation of electrical connections to and between the instrument and other peripheral devices.

Plugs are inserted into the alarm and 4-20mA/RS-485 cable bulkheads when shipped, to ensure a watertight seal. These plugs should be removed and discarded when cabling to either of these connections.

The power cable bulkhead will accept cable diameters from 5.8mm (.230 in.) up to 10 mm (.395 in.). All terminals are designed to accept wires in the range of 14-28 AWG. All wires should be stripped to a length of 6 mm (¼”). A strain relief strap is provided to reduce tension on the power terminals.

It is the user’s responsibility to assure that the watertight seal is maintained after the terminal box has been wired for operation. If any of the bulkheads are not tightened properly around a cable or plug, the ratings of the instrument will be jeopardized and there is a possibility of creating a shock hazard.

Note: Only qualified electricians should be allowed to perform the installation of the instrument as it involves a line voltage that could endanger life.

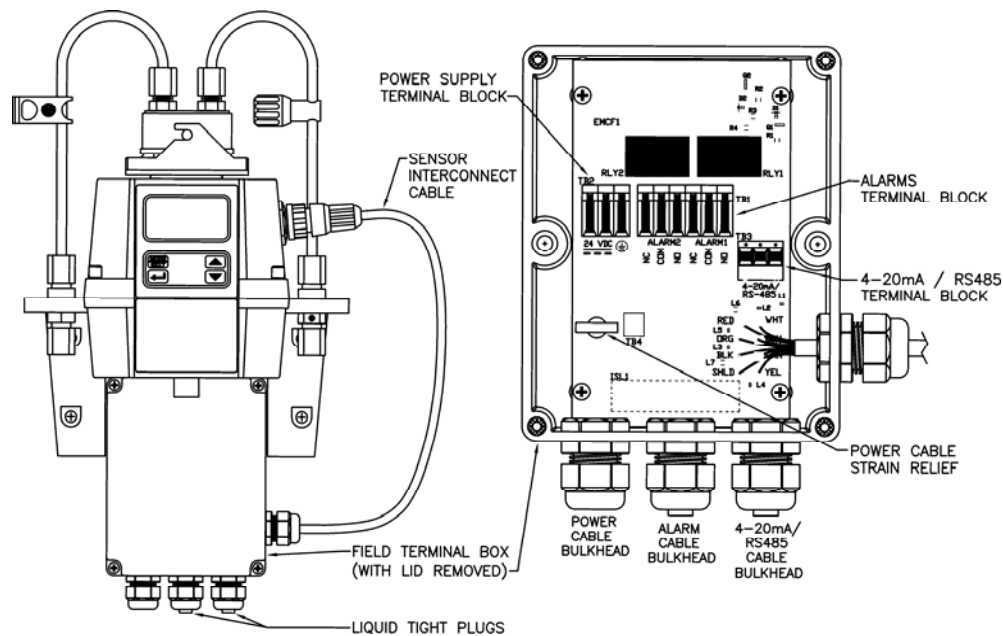

Figure 5: Electrical Connections for the Instrument

3.3.1 Power: The instrument is equipped with a 100-240 VAC, 47-63 Hz switching power supply; please verify that the line voltage falls within these specifications. It is recommended that a circuit breaker be placed prior to the power connection to allow for service. While making connections, refer to Figure 5. **The Micro TOL is not supplied with a power cord.**

3.3.2 RS-485: The RS-485 half-duplex (2-wire) digital interface operates with differential levels that are not susceptible to electrical interferences. This is why cable lengths up to 3000 ft can be implemented. The last device on each bus may require terminating with a 120-ohm resistor to eliminate signal reflection on the line. Do not run RS-485 cables in the same conduit as power.

To prevent damage to the instrument, ensure that power is disconnected prior to making connections. For ease of connecting, remove the plug in terminal block. Connections are labeled beneath this termination.

3.3.3 Relays: The Alarm 1 and Alarm 2 relays are mechanical relays rated at 240 VAC 2A. Please note that the relays are labeled NO (Normally Open), NC (Normally Closed) and C (Common). As these alarms are configured fail-safe, the normal condition is with power applied to the Micro TOL and in a non-alarm condition. Operation of these alarms is covered in section [7.4 Configuring the Alarms](#).

3.3.4 4-20 mA: The 4-20 mA output is driven by a 15 VDC power source and can drive recorder loads up to 600 ohms. This 4-20 mA output is isolated from line power and earth ground. Do not run 4-20 mA cables in the same conduit as power. Operation of this output is covered in section [7.2 Setting the 4-20 mA](#). Optional transformer isolated outputs are available as a factory installed option (Catalog No. 21045A).

Note: The installation of the 4-20 mA isolator will render the RS-485 non-operational.

Ensure each instrument is not powered when connecting the 4-20 mA. To prevent damage to the instrument, ensure that power is disconnected prior to making connections. For ease of connecting, remove the plug in terminal block. Polarities of the connections are labeled beneath this termination.

4.0 Operation

This process turbidimeter allows for the measurement of the turbidity of process water on-line. The turbidity of the process water is usually reported in Nephelometric Turbidity Units (NTU), but may be reported in Formazin Nephelometric Units (FNU). Readings above 1000 NTU (100 for models 20055 & 20056) are outside the range of this instrument. Readings above 1100 NTU (110 for models 20055 & 20056) will cause the display to flash indicating an over range condition.

During normal operation, the instrument will have the arrow beside **AUTO** highlighted with the current scale displayed on the lower row of the display and the measured reading on the upper row of the display (see illustration below).



4.1 Routine Measurement

The following steps describe how to measure the turbidity of a sample using this instrument:

1. Apply power to the instrument and allow the unit to warm up (typically 45 minutes – 1 hour on initial commissioning).
2. When a continuous process stream is flowing through the instrument, the instrument will display the measured turbidity level of the sample by displaying it on the LCD screen. In addition, the equivalent signal is provided on the analog (4-20 mA) output, or the digital output, depending on the options selected.

4.2 Security Access Feature

The instrument is equipped with a security access code feature that can be activated in the configuration mode. If the security feature is enabled, the screen shown in the illustration below will appear when the **MODE/EXIT** button is pressed.

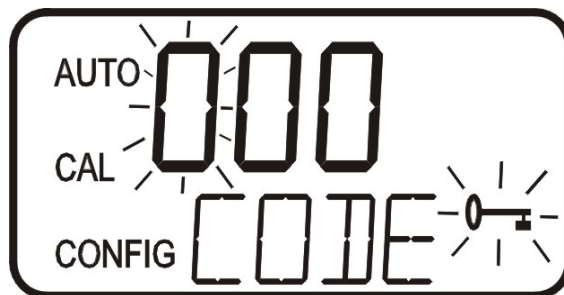

The security code (333) must be entered to gain access to **CAL** or **CONFIG** menus. Notice that the first number in the code is flashing; the flashing indicates that this is the number to be changed. Use the **▲** or **▼** arrows to select the first of the three numbers in the code and then press the **↵** button to accept the first number of the code. Now enter the second number in the code. Proceed as with the first number followed by **↵**. Then repeat the process for the third number in the access code, and finish with the **↵** button.

If the valid access code has been selected, the instrument will be directed to the calibration mode. If the wrong access code is selected, the instrument will return to the **AUTO** mode. Refer to section [7.6 Enabling the Security Access](#) for more information.

5.0 Instrument Calibration

The instrument was calibrated and tested prior to leaving the factory. Therefore, it is possible to use the instrument directly out of the box. Under normal conditions, re-calibration is recommended at least once every three months¹.

Relay contacts are held at the last valid condition and will not change state while the instrument is in the calibration and/or in the configuration mode. While in the calibration mode, the instrument has a time-out feature that automatically returns the system operation to the **AUTO** mode after a fifteen (15) minute period of inactivity.

5.1 Calibration Standards

If the Micro TOL will be used over the entire range of .02 to 1000 NTU a complete calibration as described below will be required. If instrument accuracy is only required below 10 NTU, such as potable water, a calibration may be performed using only a 10 NTU and a 0.02 NTU standard. To calibrate starting at the 10 NTU, press the ▼ button to bypass the 1000 NTU and proceed to Section [5.2 Calibration Procedures](#), step 5.

We recommend that the following materials be used during calibration to achieve the full-scale accuracy stated in this manual:

1. 0.02 NTU **PRIMEIME** Calibration Standard available from HF scientific inc.
2. 10.0 NTU **PRIMEIME** Calibration Standard available from HF scientific, inc.
3. 1000 NTU **PRIMEIME** Calibration Standard available from HF scientific, inc.

It is well known that diluted Formazin is unstable. If Formazin is used to calibrate the instrument, ensure that a fresh stock suspension of Formazin is used to achieve the accuracy quoted for the instrument. A Formazin Stock Solution Kit is available from HF scientific, inc. (Catalog No. 50040). The HF scientific, inc. **PRIMEIME**, primary calibration standards (refer to section [11.0 Accessories and Replacement Parts List](#)) are more stable than Formazin and have a minimum shelf life of 12 months. Prior to recalibration, review the expiration dates, to ensure that the standards have not expired.

Note: The range of Models 20055 & 20056 is .02 to 100 NTU. For calibrating these models replace the 1000 NTU standard with a 100 NTU standard.

¹ The EPA recommends that on-line turbidimeters be calibrated with a primary standard at least once every three months if they are to be used for EPA reporting.

5.2 Calibration Procedures

1. Select the calibration function of the instrument by pressing the **MODE/EXIT** button once. The arrow beside **CAL** will be illuminated on the display. The lower display shows alternating **1000** (the value of the standard that is requested) and \downarrow . The upper display shows the real-time reading to allow the standard to be indexed. Refer to section **6.1** for information on indexing cuvettes.

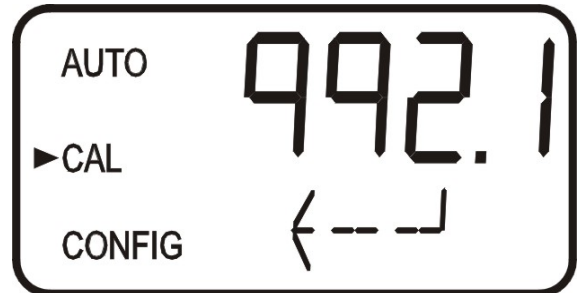
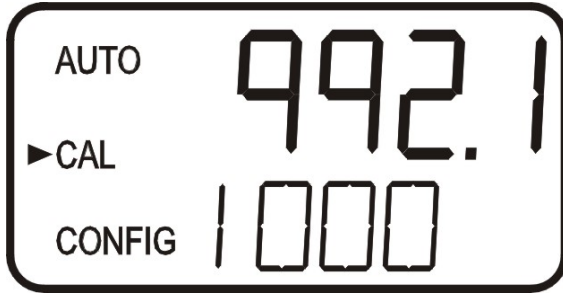

2. Remove the flow through unit.
3. Insert the requested 1000 NTU standard. Index the standard to the lowest value on the upper display.
4. Press the \downarrow button to accept the calibration.
5. The lower display will count down the progress of the calibration step.
6. The lower display will now change to show alternating **10** and \downarrow , requesting the 10.0 NTU standard.

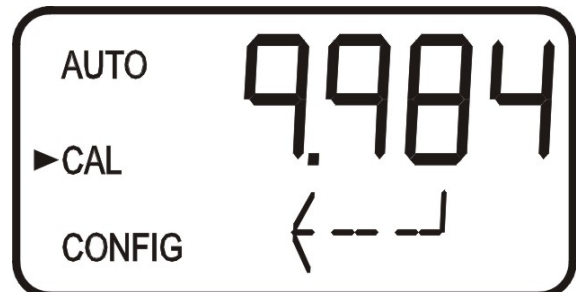
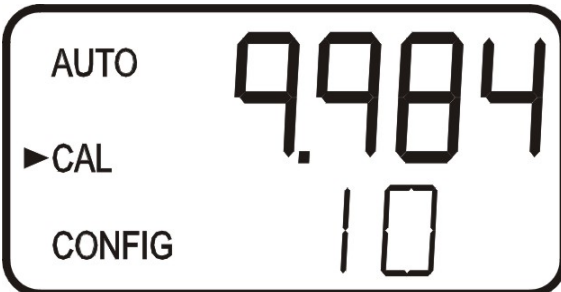

7. If the alternating **10** and \downarrow is not displayed, push the \uparrow or \downarrow until this display is shown.
8. Insert the requested 10.0 NTU standard. Index the standard to the lowest value on the upper display.
9. Press the \downarrow button to accept the calibration.
10. The lower display will count down the progress of the calibration step.
11. The lower display will now change to show **02** and \downarrow , requesting the 0.02 NTU standard.

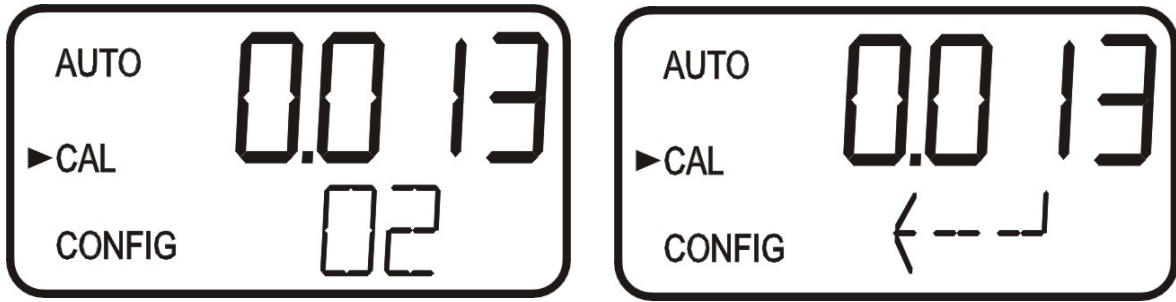

12. Insert the requested 0.02 NTU standard. Index the standard to the lowest value on the upper display.
13. Press the ↓ button to accept the calibration.
14. The lower display will count down the progress of the calibration step.
15. The instrument will return to **AUTO** mode at the end the calibration.

Note: During calibration, the fan inside the instrument is turned off to extend the life of the desiccant. The fan will be turned on during calibration countdowns and after returning to the **AUTO** mode or after five minutes, which ever comes first. It is recommended that the measurement chamber be kept covered during the calibration period and that the flow through cuvette be replaced immediately after the calibration to prevent premature saturation of the desiccant.

5.3 Calibration Error

If the screen shown below, is displayed after calibration, the internal diagnostics have determined that the calibration standards were either bad or that they were inserted in the wrong order. Either check the standards and recalibrate or restore the factory calibration see [6.2 Restoring Factory Settings](#). The instrument cannot be used without performing one of these operations.

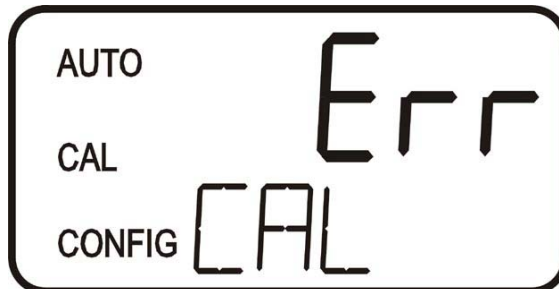

To recalibrate press the MODE key and start the calibration sequence again. To restore the factory calibration, push and hold the ▲ button. Now push and release the ↓ then release the ▲ button.

6.0 Instrument Offset

In certain instances, it may be desirable to use an offset factor to calibrate the instrument rather than performing a physical calibration of the instrument (as described in section 5.2). This procedure is not recommended in lieu of regular instrument calibration but it can be used in situations where the number of instruments used makes regular calibration prohibitive. This calibration technique will make the instrument accurate *only* at turbidity levels in the immediate vicinity of the grab sample and *not* in the full range of the instrument. Note that the **OFFSET** icon will be illuminated whenever an offset used. The maximum offset is ± 1.00 NTU. If instrument variation is greater than 1 NTU a full calibration is recommended.

The procedures are as follows:

1. Collect a grab sample of the process water that is being monitored by the instrument and record the turbidity reported by the instrument.
2. Take the grab sample and measure its turbidity using a laboratory turbidimeter (contact the HF scientific, inc. customer services department for examples of laboratory turbidimeters).
3. Compare the turbidity reported by the instrument to that obtained in the laboratory. If the readings are very close, then no offset adjustment or calibration is required and the procedure may be stopped at this step. However, if the readings are substantially different (but less than 1 NTU), continue on in this procedure to utilize the offset option to improve the turbidity reading of the instrument so that it will agree with the laboratory reading between calibrations.
4. Select the offset function of the instrument by pressing the **MODE/EXIT** button until the arrow beside **CONFIG** is illuminated on the display. Refer to the following screen.
5. Push the \downarrow button until **OFST** is displayed on the lower row.
6. At this point, the lower row of the display will indicate the operational status of the offset function (**On** or **OFF**). Change this status by using the \uparrow and \downarrow buttons. Once the desired operational status of the offset function has been set, press the \downarrow button to accept it. If the option was turned off, return to **AUTO** mode by pressing **MODE/EXIT**.

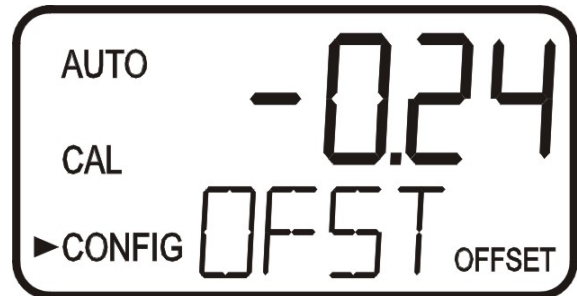

7. If the option was turned **On**, the upper row will display the offset required. This will add or subtract the value of the offset to the measured NTU value. As an example if the Micro TOL measures the process at 0.16 NTU but the laboratory instrument read the sample at 0.12 NTU, adding an offset of -0.04 would result in the Micro TOL displaying 0.12 NTU.

Select the desired offset level using the \blacktriangle and \blacktriangledown buttons. Once the desired level has been set, press the \blacktriangledown button to accept it.

8. This completes the offset configuration.
9. At this point, the instrument will continue through the configuration (**CONFIG**) mode of the instrument or press **MODE/EXIT** to return to the **AUTO** mode.

6.1 Indexing Calibration Cuvettes

To achieve the greatest accuracy, and account for normal scratches and aberrations in cuvette glass when calibrating, HF scientific inc. recommends indexing the cuvettes.

Standards and standard kits purchased from HF scientific are supplied with indexing rings.

The following steps allow repeatable indexing of calibration standards:

1. With the instrument in AUTO mode insert the standard.
2. Slowly rotate the standard, inside the optical well, one complete revolution (360°). While rotating the standard slowly, observe the measured turbidity and locate the position of the cuvette having the lowest reading.
3. With the calibration standard positioned at the location having the lowest turbidity reading, install the Indexing Ring over the cap on the standard so that the pointer of the Indexing Ring faces directly forward.

When using the standards in future, always insert the standard so that the pointer of the indexing ring faces forward. Slowly rotate the standard back and forth about 5° to find the lowest point. The standard is now indexed and ready for use.

6.2 Restoring Factory Settings

If the instrument is unable to perform a calibration due to a low lamp output or a calibration using the wrong standards, the instrument will display **CAL** on the lower row of the display and **Err** on the upper row. The operator has two choices to correct this problem. If the operator can determine whether a poor calibration or a low lamp caused the problem, he/she can remedy the problem and recalibrate. If all else fails, the operator may restore the factory calibration and configuration settings by performing the following operation. Push and hold the \blacktriangle button. Now push and release the \blacktriangledown then release the \blacktriangle button. Factory calibration and factory configuration have now been restored.

Note: Restoring the factory settings allows the use of the Micro TOL with reduced accuracy. The original problem still exists and must be determined and corrected before accurate operation of the Micro TOL will be resumed.

7.0 Instrument Configuration (CONFIG mode)

The instrument has been designed to provide the ability to customize the instrument according to needs at any time during normal operation. This mode has been split into sub-menus to facilitate instrument configuration. This section describes how to use each of the sub-menus to configure the instrument. While in the configuration mode, the instrument has a time-out feature that automatically returns the system operation to the **AUTO** mode after a fifteen (15) minute period.

Enter the **CONFIG** mode of the instrument by pressing the **MODE/EXIT** button until the arrow beside **CONFIG** is illuminated, then press the \downarrow button.

Note: To exit the **CONFIG** mode, press the **MODE/EXIT** button.

7.1 Selecting the Output (O/P)

The first configuration selection is the **O/P**. The selections are **4-20** for the 4-20 mA output, **485** for the RS-485 and **OFF** if no outputs are required. Select the desired output by using the \blacktriangle and \blacktriangledown buttons. Once the desired output has been set, press the \downarrow button to accept it. The next prompts will depend on the output selected.

7.2 Setting the 4-20 mA

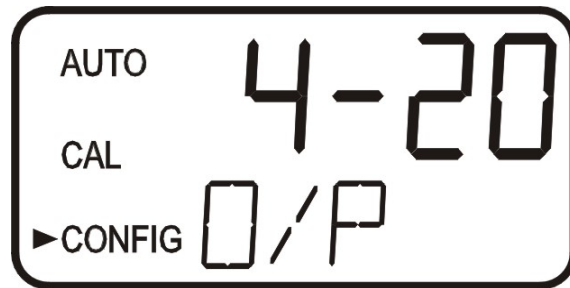

If the 4-20 mA output was turned on, prompts to set the lower (**LOLM**) and upper (**UPLM**) turbidity limits corresponding to the 4 mA and 20 mA output levels will be displayed. The first prompt will be the turbidity limit assigned to the 4 mA output level:

Select the turbidity level to assign to the **LOLM** using the \blacktriangle and \blacktriangledown buttons.

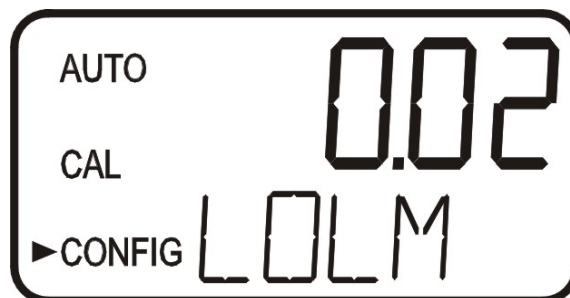

Once the desired level has been set, press the \downarrow button to accept it.

The next, prompt will be the turbidity level assigned to the 20 mA output level (**UPLM** on the lower row of the LCD display). Select the turbidity level to assign to the **UPLM** using the \uparrow and \downarrow buttons. Once the desired level has been set, press the \downarrow button to accept it.

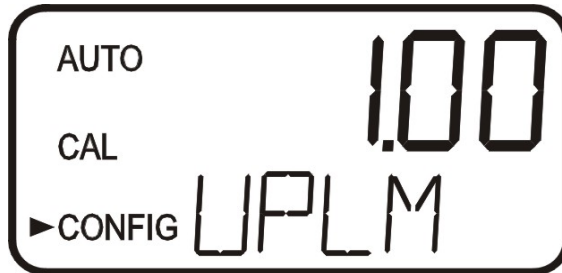

7.3 Configuring the RS-485 Port

If the instrument is equipped with this option, and the I/O selection is changed to **485**, prompts will appear for setting the baud rate and the address.

Select the correct baud rate (1200, 2400, 4800, 9600, or 19200) for operation of the I/O port by pressing the \uparrow or \downarrow buttons to change the displayed baud rate.

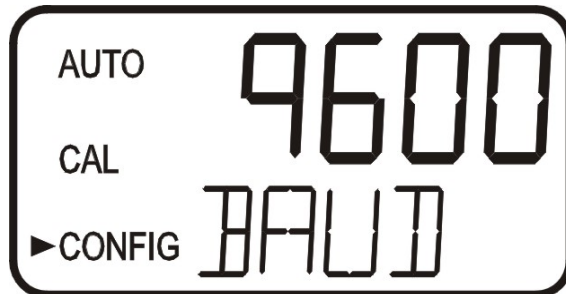

Press the \downarrow button to continue on and select the desired instrument address using the \uparrow or \downarrow buttons. Once the selection is satisfactory, press the \downarrow button.



To enable the Modbus mode, select **ASCII** or **RTU**. For more information refer to the Modbus Manual (Catalog #19777). This manual can also be downloaded for no charge at www.hfscientific.com.

7.4 Configuring the Alarms

Two relays are provided that are designed to operate as two independent programmable alarms. Three types of information must be input to fully program each alarm:

1. The alarm function (HI, LO, or OFF)
2. The alarm set point (level at which the alarm activates)
3. The delay time for the alarm: the time that the set point must be exceeded prior to alarm activation and the time before resetting the alarm (prevents ringing in the relay)

These three items are described below:

Alarm Function: The alarms can either be turned OFF or programmed to operate in one of two different manners:

1. HI alarm: the relay changes state when the measured turbidity level is higher than the programmed alarm level for a prescribed amount of time.
2. LO alarm: the relay changes state when the measured turbidity level is lower than the programmed alarm level for a prescribed amount of time.

Note: The relays automatically change state when an internal system failure is detected.

Alarm Set Point: The level at which an alarm activates is called the alarm set point. On the instrument, the alarm set point is designated as “S/P”. The set point is adjustable to any valid turbidity level over the range of the instrument in steps of 0.01 NTU.

Alarm Delay Time: The alarm delay times are used to prevent ringing of the alarm when the measured turbidity level is close to the set point. The function of the delay times is as follows:

Delay On: The turbidity level must exceed the alarm set point continuously for at least this number of seconds before the alarm activates.

If the delay on time is set at 5 seconds and the process turbidity exceeds the set point continuously for only 4 seconds, the alarm will not be activated. However, process turbidity exceeds the set point continuously for 5 seconds or more, the instrument will activate the alarm.

Delay Off: The turbidity level must not exceed the alarm set point continuously for at least this number of seconds prior to deactivation of the alarm.

If the delay off time is set to 5 seconds and the process has exited out of the alarm condition, the alarm will be reset only if the process is out of the alarm condition for a continuous 5 seconds. Otherwise, the instrument will still signal an alarm condition.

7.4.1 Alarm 1

Alarm 1 Function: The **ALM1** is displayed and the display indicates the current function of alarm 1 (**HI**, **LO**, or **OFF**). Use the **▲** or **▼** buttons to cycle through and select the desired function. Press the **↵** button to accept the selection.

If the alarm was turned **OFF** a prompt will appear to set up alarm 2 (go to section **7.4.2**). If, on the other hand, one of the other functionalities was selected a prompt will appear to set the delay times.

Alarm 1 Set Point: This prompt is used to select the set point for this alarm; this is indicated by “S/P” shown on the lower row of the display. Select the desired alarm level by using the ▲ and ▼ buttons. Once the desired set point has been set, press the ↵ button to accept it.

Alarm 1 Delay Times: Delay On: The following display will appear to allow to select the number of seconds currently set for the “delay on” time.

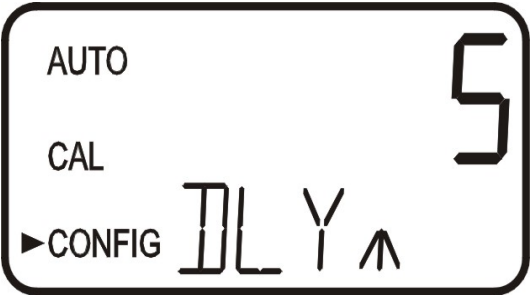

The current selected number of seconds will be shown. Select the desired number of seconds for the “delay on” time for this alarm using the ▲ and ▼ buttons. Once the desired delay time has been set, press the ↵ button to accept it.

Delay Off: Next, the following display will appear to select the number of seconds currently set for the “delay off” time.

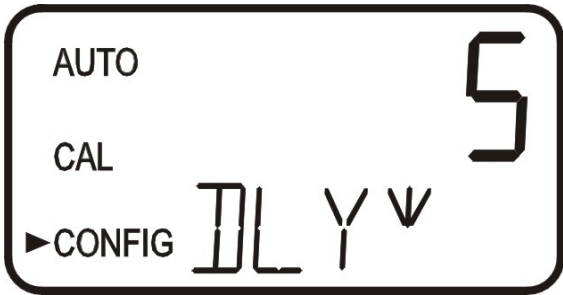

The current selected number of seconds will be shown. Select the desired delay off time for this alarm using the ▲ and ▼ buttons. Once the desired delay time has been set, press the ↵ button to accept it. After the settings for alarm 1 have been completed, prompts will allow for the set up of the information on alarm #2.

7.4.2 Alarm 2

Repeat the procedure listed in section 7.4.1 to set up the parameters for alarm 2. If one of the other functionalities is selected, a prompt to set the delay times and the set point, as with Alarm #1, will be displayed.

7.5 Offset Calibration

Refer to section 6.0 for more information on this selection.

7.6 Enabling the Security Access

The instrument is equipped with a security access. If this option is turned on, the user is required to input the access code into the instrument to get to any mode other than **AUTO**. The only code is **333**. This code may not be changed. See section 4.2 for more information on this security feature. The security key icon will be visible and flashing on the display whenever the access option is selected using the \blacktriangle or \blacktriangledown buttons. (**On** or **OFF**).

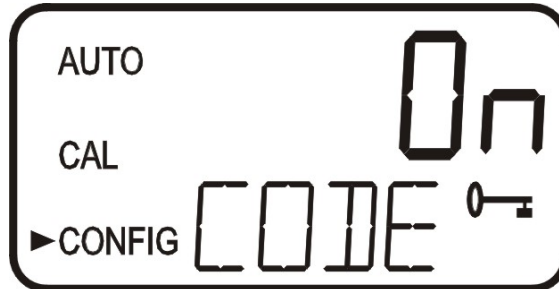

7.7 Extended Settings

The last few settings are grouped together to prevent them from being adjusted by accident. To gain access to the extended settings, select **On** using the \blacktriangle or \blacktriangledown buttons and press the \blacktriangleleft button.

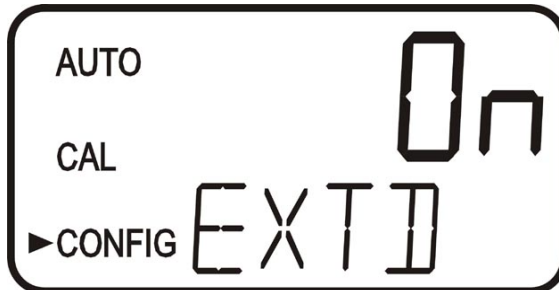

7.8 Speed of Response

The speed of response for both displayed and output values of NTU can be adjusted in this menu. The default setting is 10, however 100 response speeds are available. Although the displayed number is a relative speed, the approximate response time, in seconds, is the displayed number multiplied by 5. Select the desired speed of response using the \blacktriangle and \blacktriangledown buttons. Press the \blacktriangleleft button to accept it.

To avoid reading air and other anomalies, select the slowest speed (highest number). Select the fastest response where monitoring of rapid changes is needed.



7.9 Displayed Resolution

The instrument is equipped with the ability to display several levels of resolution. The instrument can display up to four digits to the right of the decimal place for turbidity readings below 10 NTU. The default setting is 0.01 NTU. If the last digit or two is not stable, adjust the resolution to hide these digits.

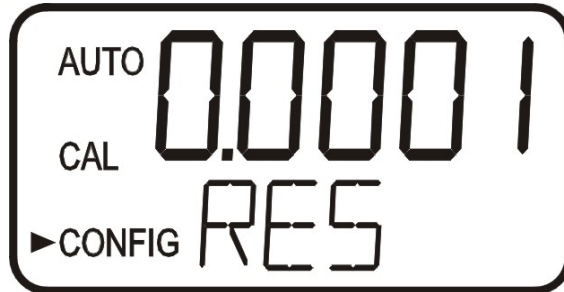

Change the resolution by pressing the \blacktriangle or \blacktriangledown button. When the desired digit resolution has been selected, press the \blacktriangledown button.

7.10 LCD Backlight Brightness

The LCD backlight brightness may need to be adjusted. This is of particular interest if multiple instruments are located in the same area and it is desired for the entire group to have the same appearance. Ten levels are available. The default brightness is 8.



Change the brightness by pressing the \blacktriangle or \blacktriangledown button. When the desired brightness has been selected, press the \blacktriangledown button.

7.11 Setting the Units

The most common unit is NTU (Nephelometric Turbidity Units) however the instrument can display in FNU (Formazin Nephelometric Units). All instruments are shipped from the factory set in NTU mode. Make a selection using the ▲ and ▼ buttons then press the ↵ button.

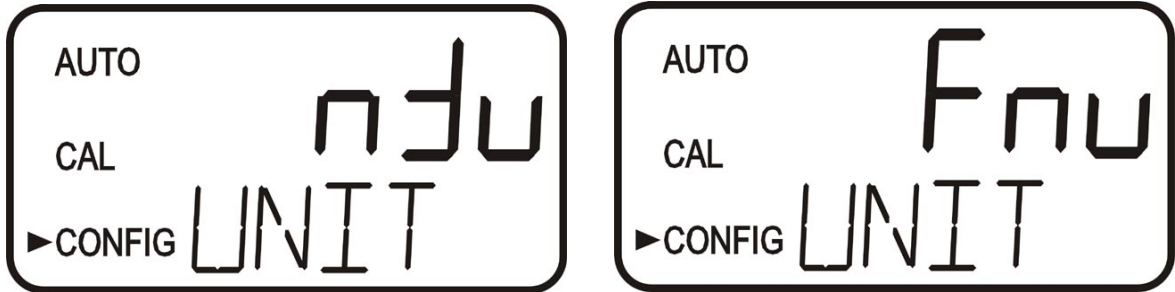

7.12 Ultrasonic Cleaning (Model 20055, 20056, 20063 & 20064)

This allows for a selection menu to turn off the ultrasonic cleaning function if desired. The default mode is On. Make a selection using the ▲ and ▼ buttons then press the ↵ button.

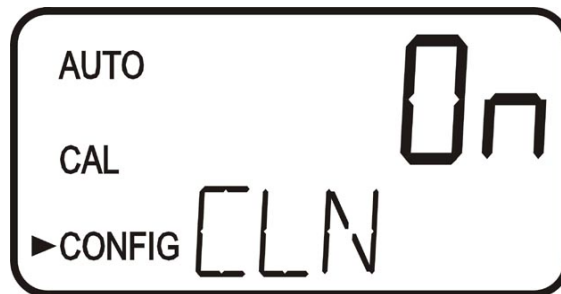

7.13 RS-485 Parameters

For instruments manufactured on or after June 2003, the following menu can be used to modify the RS-485 parameters. These menus will only appear if the RS-485 is enabled (see 7.1). The default is 8 Bit, no (nOnE) Parity, 1 Stop Bit. Make selections using the ▲ and ▼ buttons then press the ↵ button to move to the next menu.

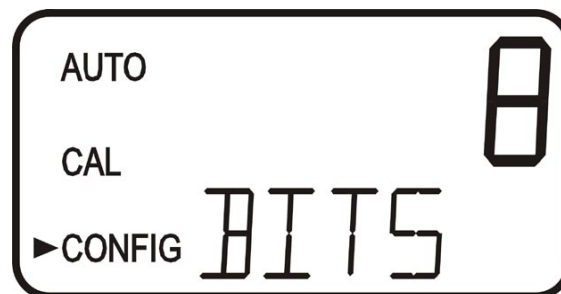

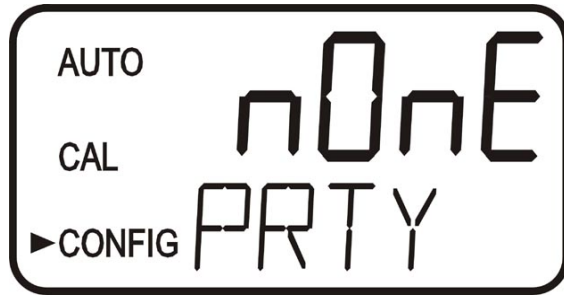

7.14 Desiccant Alarm

When the humidity detector in the Micro TOL indicates that the internal environment is close to the point where humidity could cause condensation, the instrument will display **DESC** as a warning. If desired, a desiccant warning can activate the alarms and send the 4-20mA to 2mA. To activate the alarms when the desiccant fails, select **On** in the **DESC** menu. The default for this menu is **OFF**. Make selections using the **▲** and **▼** buttons then press the **↵** button to move to return to **AUTO** mode.

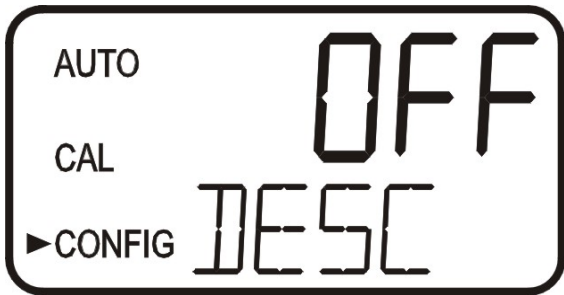

7.15 Saving Configuration Settings

If extended settings are set to **OFF**, pressing the **↵** button will save all settings and the Micro TOL will automatically return to the normal **AUTO** mode of the instrument.

If extended settings are set to **On**, after the last menu of the extended settings, pressing the **↵** button will save all settings and the Micro TOL will automatically return to the normal **AUTO** mode of the instrument.

The **CONFIG** menu may be used at any time to reset or change any of the parameters. The **CONFIG** menu may be exited at any point in the menu by using the **MODE/EXIT** key. Any features that have been modified will be saved.

8.0 Additional Features and Options

8.1 Backlit LCD

The backlit LCD allows for easier readability of the LCD display in low light or no light conditions. The backlight is intended for continuous operation. The brightness is adjustable from a menu in the **CONFIG** mode.

8.2 Ultrasonic Cleaning (Models 20055, 20056, 20063 & 20064)

This factory installed option is used to continuously clean the flow through cuvette. It is not intended to clean cuvettes that are already dirty, or replace manual cleaning entirely. The system will increase the time between cleanings dramatically. Please note that the system requires the use of a special cuvette. This cuvette must be used for the system to operate correctly.

The system works by sending an ultrasonic frequency through spring connections into a piezo transducer bonded to the bottom of a flow through cuvette (refer to figure 6).

The system can detect that an incorrect cuvette is installed, an error has occurred in the transducer or the transducer is not making contact with the spring connections. This error is indicated by **CLN** being posted to the lower screen. Since this is an error condition, the alarms will be set and the 4-20 mA will be sent to 2 mA.

If the correct cuvette is installed, and the error is still posted, try rotating the flow through unit slightly to improve the connection. If this fails to work, the cuvette may have to be replaced (Catalog #24166S). The detection for this cuvette only operates in **AUTO** mode. If the system is operating correctly **AUTO** will flash on the display.

Note: **The cuvette must be completely dry before it is inserted into the sensor. If there is any visible moisture present on the cuvette or transducer, there is a great risk of damaging the sensor electronics and the transducer. Be sure to clean and dry the cuvette completely just before inserting it into the sensor.**

After installing a cuvette, there will be a 30 minute period where the lower screen will post **DRY** to the lower screen. During this time, the ultrasonic circuit will not operate to allow the Vapor Purge system to remove all moisture from the ultrasonic transducer. The Vapor Purge system can NOT remove large droplets of water, only residual moisture. The **DRY** message is normal and is not considered an alarm condition; therefore no alarms will be implemented. If the cuvette is removed during this period no **CLN** alarm is posted until the 30 minute **DRY** period times out.

Note: **For the Vapor Purge system to function properly, all instrument seals must be maintained and the desiccant pack must be in good condition (no DESC display).**

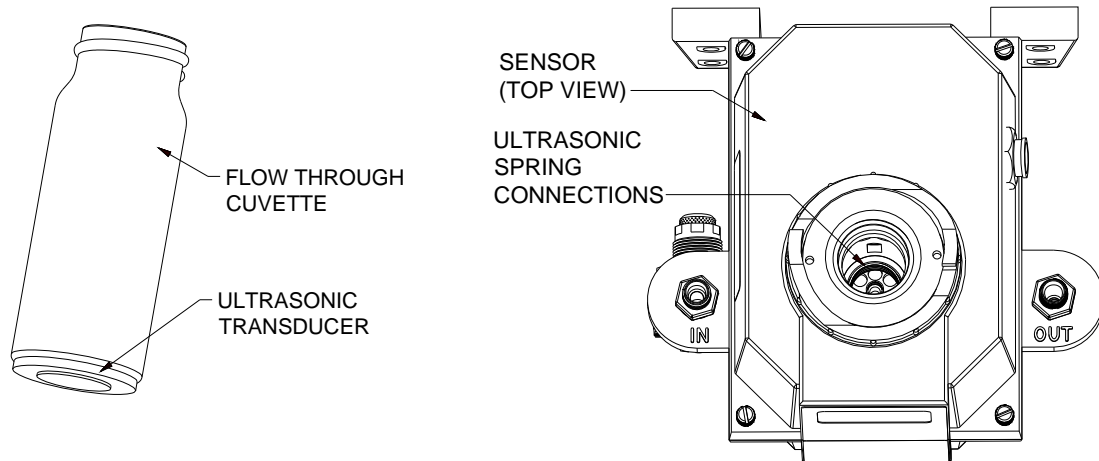

Figure 6: Operational parts of the Ultrasonic Cleaning System

8.3 RS-485 Outputs

The Micro TOL has the capability to operate in three different RS-485 modes for all models. Included is a mode for interfacing into the HF Online software package (section 8.3.1 below), and a simple communication mode. A third operating mode is the Modbus communications. All modes will automatically configure and do not require any changes or selections.

8.3.1 HF Online (HF catalog # 19783)

The Micro TOL can operate as a small SCADA system with an optional PC software package, called HF ONLINE. This system allows for an interface with up to 255 Micro TOL's for the purpose of data logging. This system will interface directly with common database and spreadsheet software.

8.3.2 Simple Communication

The Micro TOL can provide basic communications over simple programs such as the Hilgraeve HyperTerminal that is included with most Microsoft Windows packages. The user could also use Visual Basic or other programs. The default communication parameters are 8 bits, no parity and 1 stop bit. These can be changed in the Extended CONFIG menus 7.13 RS-485 Parameters.

The master computer will send out:

- Byte #1 the attention character “:” in ASCII or 3A Hex
- Byte #2 the address of the Micro TOL being queried
- Byte #3 & 4 CR LF or 0D 0A in hex

The Micro TOL will respond with:

- The same attention character “:” in ASCII or **3A** Hex
- The address of the Micro TOL
- The Reading
- The Unit (NTU)

A sample communication would look like this:

(Master computer requesting a report from address #1) **: 1 CRLF**
 (Micro TOL set to address #1 Response) **:001 0.0249 NTU**

8.3.3 Modbus Communication

Modbus protocol communication is operational on all models. The Modbus information is covered in a separate manual (Catalog # 19777). This manual is also available as a free download from our website at www.hfscientific.com.

8.4 Flow Alarm (Catalog # 19945A)

The flow switch for the Micro TOL is a factory-installed option. This option indicates a “Low Flow” condition by switching both relays to the fail state and setting the 4-20 mA signal to 2 mA. There is also a screen indication of the low flow condition and a modbus register is set.

8.5 Flow Controller (Catalog # 19778)

The flow controller limits the flow, in high-pressure systems, to safe flow limits of less than 1 liter/minute.

8.6 Remote Panel Meter (Catalog # 19609)

The remote panel meter allows for remote indication of the NTU reading using the 4-20 mA loop. No external power is required as the meter is run off of the 4-20 mA source.

9.0 Troubleshooting & Maintenance

9.1 Micro TOL Fault Detection

The Micro TOL performs continuous diagnostic monitoring. In the Micro TOL there are three levels of fault detection; warnings, errors and failures. Any faults are displayed in a queue form in the bottom row of the LCD.

A **warning** is simply a screen indication of a problem. No alarms are activated. If the desiccant alarm is turned off and the desiccant becomes saturated, a screen warning of **DESC** will appear.

An **error** indicates a failure or a problem that usually can be corrected by the operator. These errors consist of lamp out (**LAMP**), 4-20 mA loop open (**MA**), bad calibration (**CAL**), if desiccant alarm activated and replacement required (**DESC**), if enabled no flow (**FLOW**) (if equipped with the flow switch). If the Micro TOL is equipped with ultrasonic cleaning, an additional message will indicate that the ultrasonic transducer is not making contact or the flow through has been removed (**CLN**). If any of these conditions occurs, both alarm relays will be activated and the 4-20 mA output will be held at 2 mA. If any of these errors occur the instrument will still display readings, however the accuracy is not known and the instruments readings should not be trusted.

A **failure** is a system fault. This is NOT a problem that the operator can correct, and the unit must be returned to the factory for service. These failures consist of failures in the CPU, A/D, EEPROM or other devices internal to the instrument (**FAIL**). If a failure occurs, the instrument will not function properly and will display the word FAIL on the lower row, both alarm relays will be activated and the 4-20 mA output will be held at 2 mA (if 4-20 mA is selected).

If any fault conditions occur, the message indicating the fault will be shown on the lower row of the display.

9.2 System FAIL Message

Normally, this condition indicates that the instrument will require servicing. Contact either the HF scientific, inc. Technical Service Department or the HF scientific, inc. Customer Service Department.

HF scientific, inc.
3170 Metro Parkway
Fort Myers, Florida 33916-7597
Phone: (239) 337-2116
Fax: (239) 332-7643
Email: info@hfscientific.com
www.hfscientific.com

9.3 Diagnostic Chart

Symptom	Cause	Cure
Lower display shows MA	4-20 mA loop open	Check wiring. See sections 3.3.4 and 7.2
Lower display shows DESC	Desiccant pouch bad	Change desiccant pouch. See section 10.2
Lower display shows LAMP	Lamp failed	Replace lamp. Refer to section 10.3
Lower display shows FLOW	Sample flow has stopped	Restore flow. Contact HF about factory installed option
Lower display shows FAIL	Major system fault	Refer to section 9.1 & 9.2
Readings are higher than expected	(1) Bubbles in solution	(1) Ensure that the drain vent is open and is not obstructed. See section 3.2.2. (2) Apply backpressure. See section 3.2 and figure 4 (3) For sever cases of bubbles a stilling chamber is available. Call HF scientific. Part# 20106
	(2) Condensate or leaky cuvette	Check flow through cuvette for condensate or leaks.
	(3) Flow through cuvette dirty	Clean cuvette. See section 10.1
	Instrument out of calibration	Recalibrate. Refer to section 5
Readings are erratic	(1) Bubbles in solution	(1) See above
	(2) Debris in flow through	(2) Clean debris from cuvette
Readings are lower than expected	Instrument out of calibration	Recalibrate. Refer to section 5
Upper display flashes	Sample Over-Range	Check sample. Sample may be too high to read.

9.4 Technical and Customer Assistance

If for any reason assistance is needed regarding this instrument please do not hesitate to contact either the HF scientific, inc. Technical Service Department or the HF scientific, inc. Customer Service Department:

HF scientific, inc.
3170 Metro Parkway
Fort Myers, Florida 33916-7597
Phone: (239) 337-2116
Fax: (239) 332-7643
Email: info@hfscientific.com
www.hfscientific.com

10.0 Routine Maintenance

10.1 Cleaning the Flow Through Cuvette

Measurement cuvettes used for both grab sample and the flow through should be clean and free of marks or scratches. Cleaning is accomplished by cleaning the interior and exterior with a detergent solution and then rinsing several times with distilled or de-ionized water. The cuvette can be replaced by first shutting off the flow using the provided shutoff clamp; unscrewing the old cuvette and replacing with a fresh clean one.

10.2 Replacing or Installing the Desiccant Pouch

The Micro TOL continuously checks the condition of the desiccant. When the desiccant gets in such a condition that it may cause problems, the instrument will display **DESC** on the lower portion of the display to indicate the presence of humidity. See [7.14 Desiccant Alarm](#).

Proper use of the supplied desiccant is essential in maintaining the performance of the instrument. The desiccant has been designed to have a long life; however, replacement of the desiccant pouch will be required from time to time.

It is essential that the enclosure seal on the instrument base be maintained to ensure adequate desiccant life. Inspect the seal each time the desiccant pouch is replaced. Replace or reseal the seal if it is found to be defective.

The desiccant should be replaced when the instrument displays **DESC**. A new sealed desiccant pouch and indicator card are available from HF scientific inc. part #21555R. To initially install or remove the old desiccant, simply unscrew the four corner thumbscrews and remove the electronics half of the instrument. Open the bag protecting the new desiccant pouch and replace (or install for a new instrument) in the instrument base assembly. To speed up the recognition, by the instrument, of the new desiccant it will be necessary to reset the instrument by disconnecting the sensor interconnect cable for 2 seconds and then reconnecting it.

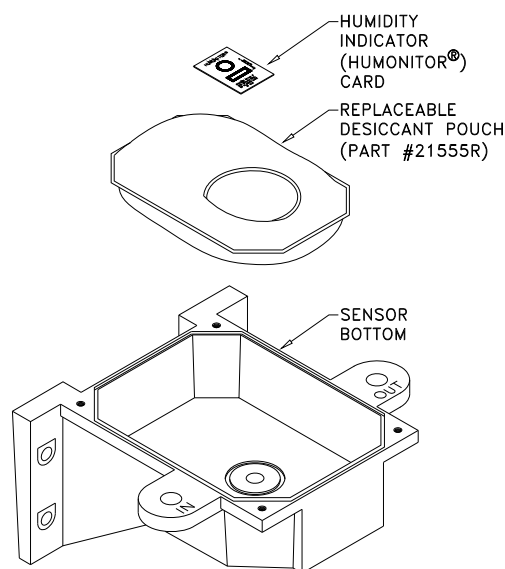

Note: Once the bag is opened, install the desiccant pouch immediately to prevent premature degradation of the desiccant.

10.3 Replacing the Source Lamp

The source lamps in the Micro TOL's are designed for long life. The IR lamp is rated for 10 years and the white light version is rated for 7 years. If the lamp should need replacement, we recommend calling HF Service Department for assistance.

11.0 Accessories and Replacement Parts List

The items shown below are recommended accessories and replacement parts.

Accessory	Catalog Number	
	White Light	Infrared
Electronic Service Module For Micro TOL 1	02049	02051
Electronic Service Module For Micro TOL 2	02053	02054
Electronic Service Module For Micro TOL 3	02055	02056
Electronic Service Module For Micro TOL 4	02063	02064
Operating Manual, Micro TOL	24034	
PRIME TIME Calibration Kit, .02, 10 & 100 NTU	19953	
PRIME TIME Calibration Kit, Full Range, .02, 10 & 1000 NTU	19957	
Formazin Stock Kit	50040	
Formazin Stock Solution, 4000 NTU, 500 ml	70914	
Replacement Desiccant Pouch	21555R	
Software for data collection and reporting	19783	
Flow Regulator, Micro TOL	19778	
Pressure Regulator	24306S	
Replacement Cuvette with Ultrasonic Transducer	24166S	
Tubing Kit Containing: 1-shutoff clamp, 1-backpressure valve, 2-connecting tubing with fittings for flow through assembly, drain vent.	21062	

To order any accessory or replacement part, please contact the HF scientific, inc. Customer Service Department. If for any reason technical assistance is needed regarding this instrument please do not hesitate to contact the HF Technical Services Department.

HF scientific, inc.
3170 Metro Parkway
Fort Myers, Florida 33916-7597
Phone: (239) 337-2116
Fax: (239) 332-7643
Email: info@hfscientific.com
www.hfscientific.com

12.0 Warranty

HF scientific, inc., as vendor, warrants to the original purchaser of this instrument that it will be free of defects in material and workmanship, in normal use and service, for a period of one year from date of delivery to the original purchaser. HF scientific, inc.'s, obligation under this warranty is limited to replacing, at its factory, the instrument or any part thereof. Parts, which by their nature are normally required to be replaced periodically, consistent with normal maintenance, specifically reagent, desiccant, sensors, electrodes and fuses are excluded. Also excluded are accessories and supply type items.

Original purchaser is responsible for return of the instruments, or parts thereof, to HF scientific, inc.'s factory. This includes all freight charges incurred in shipping to and from HF scientific, inc.'s factory.

HF scientific, inc. is not responsible for damage to the instrument, or parts thereof, resulting from misuse, environmental corrosion, negligence or accident, or defects resulting from repairs, alterations or installation made by any person or company not authorized by HF scientific, inc.

HF scientific, inc. assumes no liability for consequential damage of any kind, and the original purchaser, by placement of any order for the instrument, or parts thereof, shall be deemed liable for any and all damages incurred by the use or misuse of the instruments, or parts thereof, by the purchaser, its employees, or others, following receipt thereof.

Carefully inspect this product for shipping damage, if damaged, immediately notify the shipping company and arrange an on-site inspection. HF scientific, inc. cannot be responsible for damage in shipment and cannot assist with claims without an on-site inspection of the damage.

This warranty is given expressly and in lieu of all other warranties, expressed or implied. Purchaser agrees that there is no warranty on merchantability and that there are no other warranties, expressed or implied. No agent is authorized to assume for HF scientific, inc. any liability except as set forth above.

HF scientific, inc.
3170 Metro Parkway
Fort Myers, Florida 33916-7597
Phone: (239) 337-2116
Fax: (239) 332-7643
Email: info@hfscientific.com
Website: www.hfscientific.com

MOUNTING TEMPLATE

ALL DIMENSIONS ARE IN MILLIMETERS (INCHES)

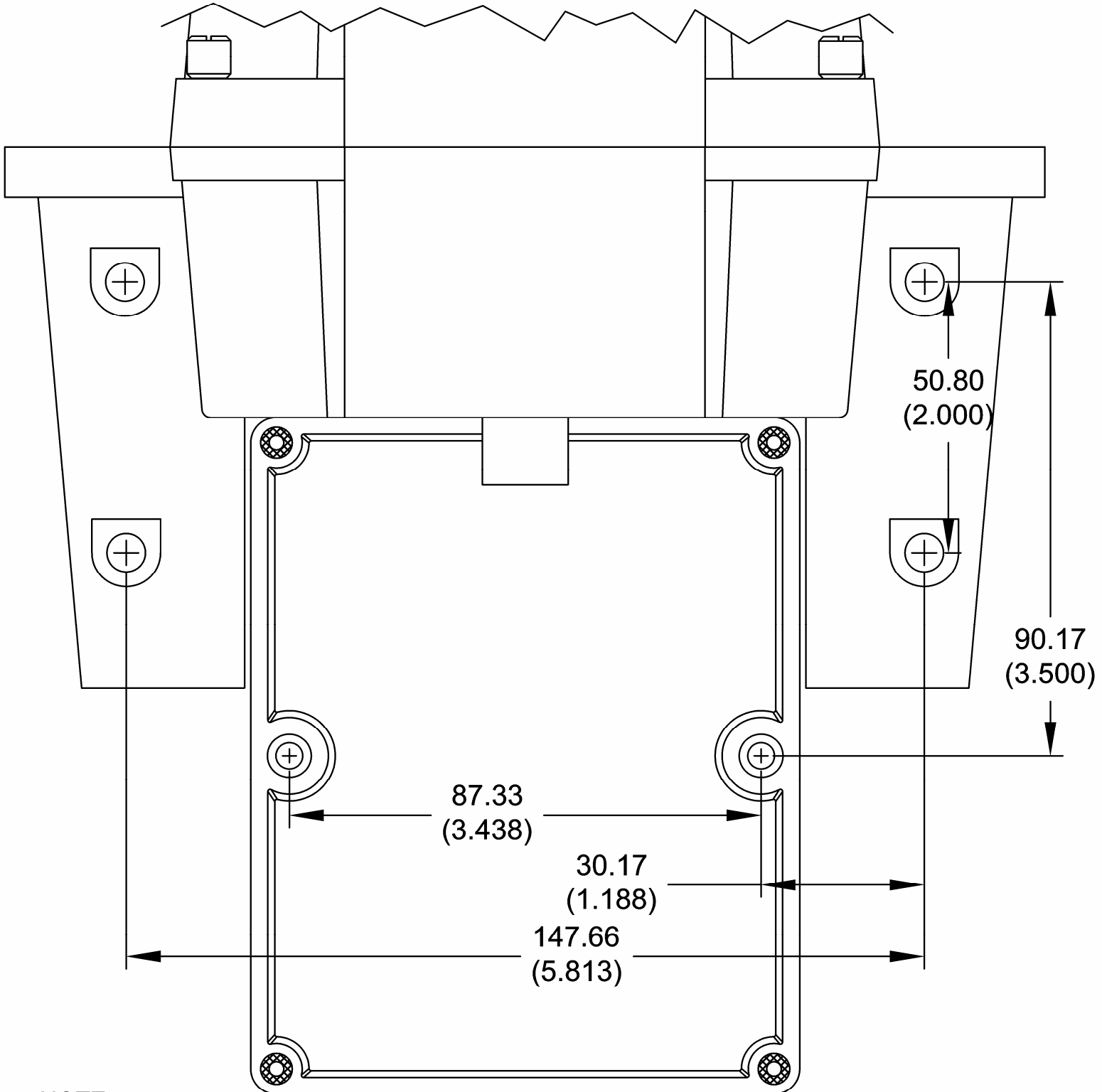

NOTE:

- 1) SEE THE MOUNTING INSTRUCTIONS IN THE MANUAL FOR MOUNTING HARDWARE SIZES.
- 2) PROVIDE AT LEAST 200 MM (8 INCHES) OF FREE SPACE ABOVE THE SENSOR FOR EASY REMOVAL OF THE FLOW HEAD AND INSERTION OF THE CALIBRATION STANDARDS.